

**THE
HEFFERNAN
GROUP**

P.O. Box 1180
Surrey Hills North VIC 3127
ABN 47 122 161 282
Phone 9836 5021
Fax 9836 5025

Student Name:

SPECIALIST MATHEMATICS

WRITTEN TRIAL EXAMINATION 2

2007

Reading Time: 15 minutes

Writing time: 2 hours

Instructions to students

This exam consists of Section 1 and Section 2.
Section 1 consists of 22 multiple-choice questions and should be answered on the detachable answer sheet on page 28 of this exam. This section of the paper is worth 22 marks.
Section 2 consists of 5 extended-answer questions, all of which should be answered in the spaces provided. Section 2 begins on page 13 of this exam. This section of the paper is worth 58 marks.
There is a total of 80 marks available.
Where more than one mark is allocated to a question, appropriate working must be shown.
Where an exact value is required to a question a decimal approximation will not be accepted.
Unless otherwise stated, diagrams in this exam are not drawn to scale.
The acceleration due to gravity should be taken to have magnitude $g \text{ m/s}^2$ where $g = 9.8$
Students may bring one bound reference into the exam.
Students may bring an approved graphics or CAS calculator into the exam.
Formula sheets can be found on pages 25-27 of this exam.

This paper has been prepared independently of the Victorian Curriculum and Assessment Authority to provide additional exam preparation for students. Although references have been reproduced with permission of the Victorian Curriculum and Assessment Authority, the publication is in no way connected with or endorsed by the Victorian Curriculum and Assessment Authority.

© THE HEFFERNAN GROUP 2007

This Trial Exam is licensed on a non transferable basis to the purchaser. It may be copied for educational use within the school which has purchased it. This license does not permit distribution or copying of this Trial Exam outside that school or by any individual purchaser.

SECTION I**Question 1**

The hyperbola with the asymptotes $y = \pm 4(x - 2)$ could have as its equation

A. $x^2 - \frac{(y - 2)^2}{16} = 1$

B. $\frac{x^2}{16} - (y - 2)^2 = 1$

C. $(x - 2)^2 - \frac{y^2}{4} = 1$

D. $\frac{(x - 2)^2}{4} - \frac{y^2}{64} = 1$

E. $\frac{(x - 2)^2}{64} - \frac{y^2}{4} = 1$

Question 2

The graph of $f(x) = \frac{1}{x^2 + px + q}$ would have only one vertical asymptote if

A. $p = q$

B. $p^2 = 4q$

C. $p < q$

D. $p^2 < 4q$

E. $p^2 > 4q$

Question 3

The maximal domain and range of the function $f(x) = \frac{\pi}{2} + \arcsin\left(\frac{x}{a}\right)$ are given by

A. $d_f = [-1, 1]$ and $r_f = \left[-\frac{\pi}{2}, \frac{\pi}{2}\right]$

B. $d_f = [-1, 1]$ and $r_f = [0, \pi]$

C. $d_f = \left[-\frac{1}{a}, \frac{1}{a}\right]$ and $r_f = \left[-\frac{\pi}{2}, \frac{\pi}{2}\right]$

D. $d_f = [-a, a]$ and $r_f = \left[-\frac{\pi}{2}, \frac{\pi}{2}\right]$

E. $d_f = [-a, a]$ and $r_f = [0, \pi]$

Question 4

The graph of $y = \operatorname{cosec}(a(x - b))$ for $x \in \left(-\frac{\pi}{4}, \frac{5\pi}{4}\right)$ is shown below.

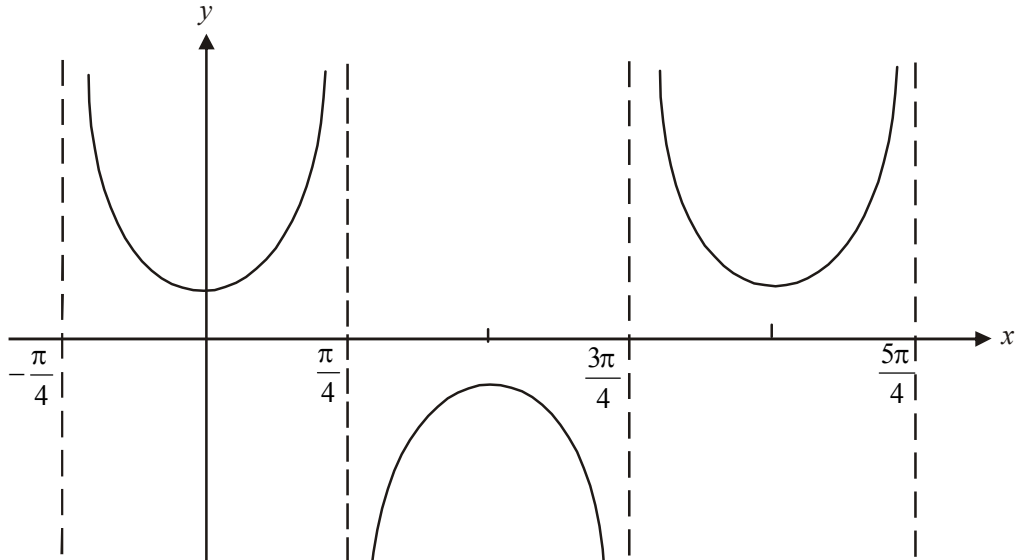

The values of a and b could be

- A. $a = \frac{1}{2}$ $b = -\frac{\pi}{4}$
 B. $a = 2$ $b = -\frac{\pi}{4}$
 C. $a = \frac{1}{2}$ $b = \frac{\pi}{4}$
 D. $a = 2$ $b = \frac{\pi}{4}$
 E. $a = \frac{1}{2}$ $b = \frac{\pi}{2}$

Question 5

If $v = a + ai$ where a is a positive constant, and $w = \operatorname{cis}\left(\frac{\pi}{3}\right)$, then $\frac{v}{w}$ is given by

- A. $2a \operatorname{cis}\left(\frac{\pi}{6}\right)$
 B. $\sqrt{a} \operatorname{cis}\left(\frac{\pi}{12}\right)$
 C. $\sqrt{2}a \operatorname{cis}\left(-\frac{\pi}{12}\right)$
 D. $\sqrt{2}a \operatorname{cis}\left(\frac{\pi}{12}\right)$
 E. $\sqrt{2a} \operatorname{cis}\left(\frac{\pi}{6}\right)$

Question 6

One of the solutions to the equation $z^{12} = a$; where a is a real number, is $a^{\frac{1}{12}} \operatorname{cis}\left(\frac{7\pi}{6}\right)$.

The number of solutions to this equation that have an imaginary part that is less than zero is

- A. 0
- B. 2
- C. 5
- D. 6
- E. 7

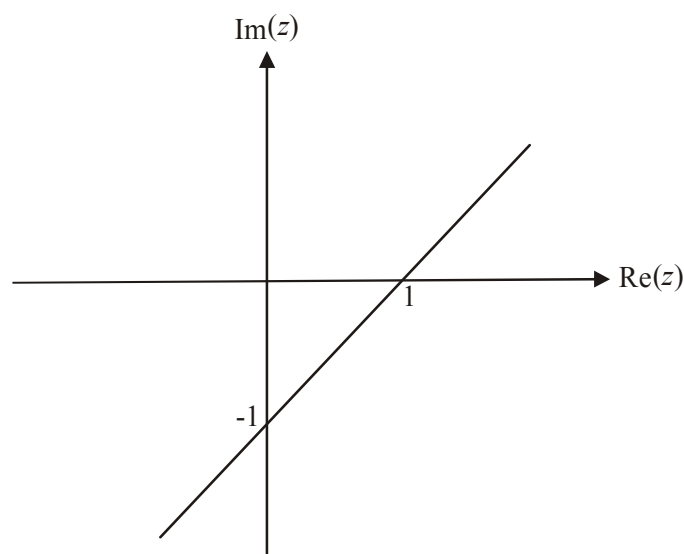
Question 7

The line shown on the Argand diagram above could be defined by

- A. $|z| = |z - 1 + i|$
- B. $|z| = |z + 1 - i|$
- C. $|z - 1 + i| = 0$
- D. $|z - 1 + i| = 1$
- E. $|z + 1 - i| = 1$

Question 8

The complex number $z = a + bi$, where a and b are real constants, lies in the second quadrant of an Argand diagram. Which one of the following statements is **not** true?

- A. $a < 0$
- B. $b > 0$
- C. zi lies in the third quadrant
- D. $|z| = \sqrt{2}|a|$ if $|a| = b$
- E. $\operatorname{Arg}(z) = \frac{\pi}{4}$ if $|a| = b$

Question 9

The gradient of the curve $x^2 - 3y^3 = 1$ at the point where $x = 2$ is given by

- A. $\frac{5}{18}$
- B. $\frac{4}{9}$
- C. $\frac{2}{3}$
- D. 1
- E. $\frac{4}{3}$

Question 10

With a suitable substitution, $\int_0^{\frac{\pi}{6}} \sin^3(x) \cos^4(x) dx$ can be expressed as

- A. $\int_0^{\frac{\pi}{6}} u^4 du$
- B. $\int_{\frac{\sqrt{3}}{2}}^1 u^4 du$
- C. $\int_0^{\frac{\pi}{6}} (u^4 - u^6) du$
- D. $\int_1^{\frac{\sqrt{3}}{2}} (u^4 - u^6) du$
- E. $\int_{\frac{\sqrt{3}}{2}}^1 (u^4 - u^6) du$

Question 11

The graph of the function $y = f(x)$ has x -intercepts at $x = 0$, $x = 3$ and $x = 8$. Also, $f'(6) = 0$ and $f(x) < 0$ for $x < 0$ and also for $3 < x < 8$.

Let $F(x)$ be the antiderivative function of $f(x)$.

Which one of the following could be the graph of $y = F(x)$?

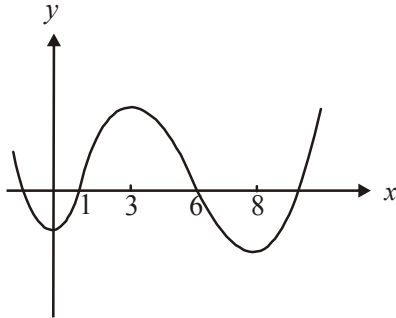
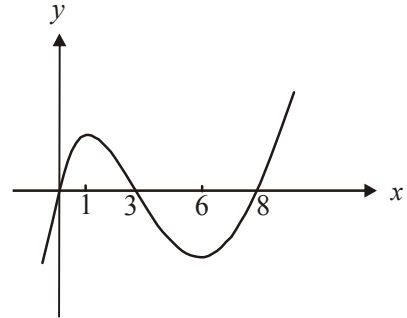
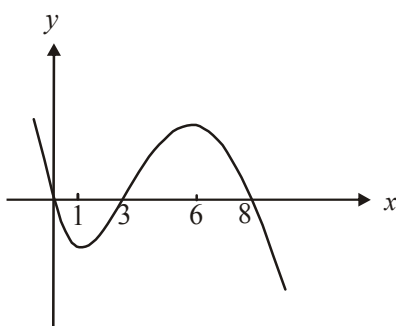
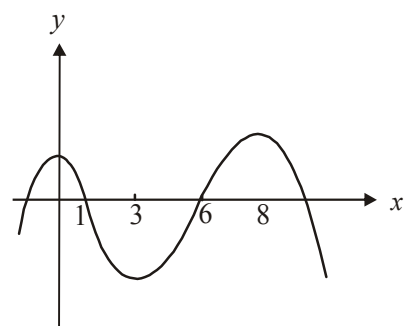
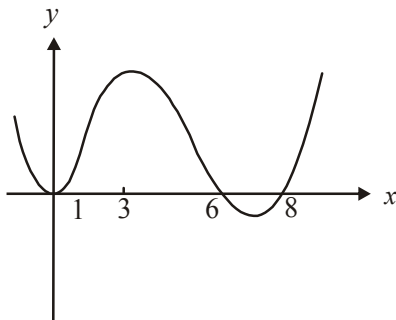
A.**B.****C.****D.****E.**

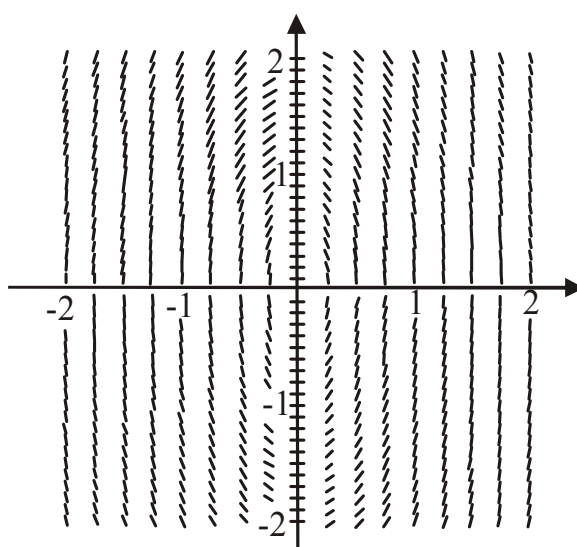
Question 12

The direction (slope) field for a particular first order differential equation is shown above. The differential equation could be

- A. $\frac{dy}{dx} = x^2 - y^2$
 B. $\frac{dy}{dx} = \frac{x^2}{4} + y^2$
 C. $\frac{dy}{dx} = x^2 + \frac{y^2}{4}$
 D. $\frac{dy}{dx} = \frac{-4x}{y}$
 E. $\frac{dy}{dx} = \frac{-4y}{x}$

Question 13

The position vectors of particles A and B are given by

$$\underline{r}_A = 4\hat{i} + (2t - 6)\hat{j}$$

$$\text{and } \underline{r}_B = (t + 1)\hat{i} + 8\hat{j}$$

where t is in seconds and $t \geq 0$.

The particles

- A. meet when $t = 3$
 B. meet when $t = 4$
 C. meet when $t = 7$
 D. meet when $t = 8$
 E. never meet

Question 14

A moving object has a position vector given by $\underline{x}(t) = \frac{1}{t}\underline{i} + \sqrt{t}\underline{j} + e^{2t}\underline{k}$ where t is in seconds and $t > 0$.

When $t = 1$, the direction of motion of the object is

- A. $-\underline{i} + \frac{1}{2}\underline{j} + \underline{k}$
- B. $-\underline{i} + \frac{1}{2}\underline{j} + 2e^2\underline{k}$
- C. $\underline{i} + \underline{j} + e^2\underline{k}$
- D. $\underline{i} + \underline{j} + 2e^2\underline{k}$
- E. $2\underline{i} - \frac{1}{4}\underline{j} + 4e^{2t}\underline{k}$

Question 15

The region enclosed by the graph of $y = x^5 + 2x^3 + x + 1$ and the x and y axes is closest to

- A. 0.34899 square units
- B. 0.34905 square units
- C. 0.73112 square units
- D. 0.79651 square units
- E. 0.85953 square units

Question 16

A solution to the differential equation $\frac{dy}{dx} = \sqrt{x-9}$, with initial conditions $y = 0$ when $x = 9$, is to be approximated using Euler's method with a step size of 0.1. The value of y when $x = 9.2$ is closest to

- A. 0
- B. 0.0142
- C. 0.0316
- D. 0.0596
- E. 1.4788

Question 17

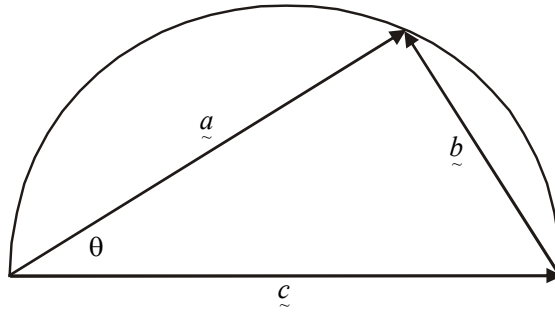

In the diagram above, vector \underline{c} lies along the straight edge of a semi-circle. Vectors \underline{a} , \underline{b} and \underline{c} form a triangle and all three vertices of the triangle lie on the semi-circle. Which one of the following statements is **not** true?

- A. $\underline{a} \cdot \underline{b} = 0$
- B. $\underline{a} \cdot \underline{a} + \underline{b} \cdot \underline{b} = \underline{c} \cdot \underline{c}$
- C. $|\underline{a}|^2 + |\underline{b}|^2 = |\underline{c}|^2$
- D. $\underline{a} \cdot (\underline{c} + \underline{b}) = |\underline{a}|^2$
- E. $\underline{a} \cdot \underline{b} = |\underline{a}| |\underline{b}| \cos \theta$

Question 18

A vector with a magnitude of 4 that is parallel to the vector $6\underline{i} + 2\underline{j} + 2\sqrt{6}\underline{k}$ could be

- A. $\frac{3}{4}\underline{i} + \frac{1}{4}\underline{j} + \frac{\sqrt{6}}{4}\underline{k}$
- B. $\frac{3}{2}\underline{i} + \frac{1}{2}\underline{j} + \frac{\sqrt{6}}{2}\underline{k}$
- C. $3\underline{i} + \underline{j} + \sqrt{6}\underline{k}$
- D. $12\underline{i} + 4\underline{j} + 2\sqrt{6}\underline{k}$
- E. $24\underline{i} + 8\underline{j} + 8\sqrt{6}\underline{k}$

Question 19

A cake which has been baked in an oven with an internal temperature of 180°C , is taken from the oven and placed on a bench. The surrounding air temperature is 22°C . The rate at which the cake cools is proportional to the excess of its temperature above the surrounding air temperature.

Let T represent the temperature of the cake at time t minutes after it is taken from the oven and k is a positive constant.

Which of the following gives a differential equation for T and t ?

A. $\frac{dT}{dt} = -k(T - 22), T(0) = 180$

B. $\frac{dT}{dt} = -k(T - 180), T(0) = 22$

C. $\frac{dT}{dt} = -k(180 - T), T(0) = 22$

D. $\frac{dT}{dt} = k(T - 180), T(0) = 22$

E. $\frac{dT}{dt} = k(T - 22), T(0) = 180$

Question 20

A particle of mass 10kg is attached to the end of a string which is fixed to a wall.
 A horizontal pulling force P is applied to the particle pulling it away from the wall.
 The particle is held in equilibrium.

If T represents the tension in the string which one of the following diagrams shows the forces acting on the particle?

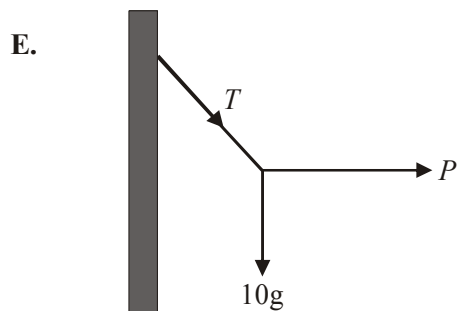
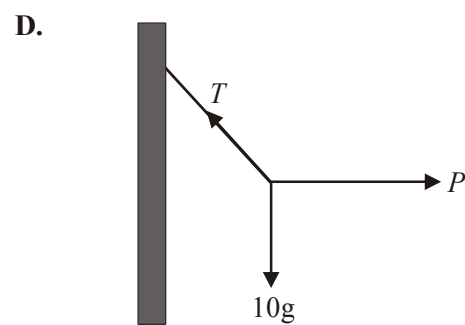
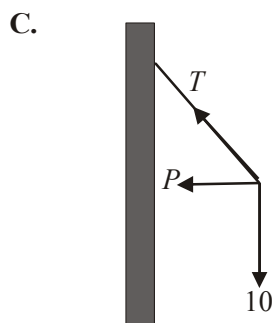
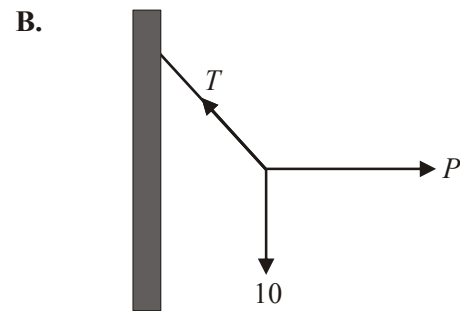
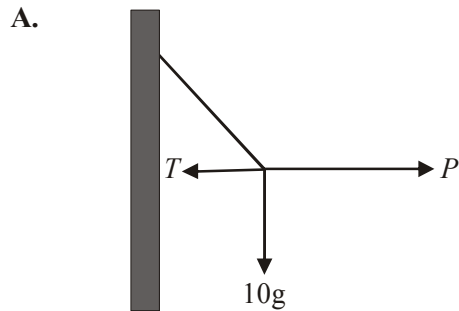

Question 21

A box of mass 20kg is sitting on a horizontal floor. A man exerts a horizontal force of 30 newtons on the box. The coefficient of friction between the box and the floor is 0.2 and the friction force is F .

The box will

- A. accelerate because $F = 30$
- B. accelerate because $F < 4g$
- C. remain at rest because $F = 4g$
- D. remain at rest because $F < 4g$
- E. be on the point of sliding across the floor

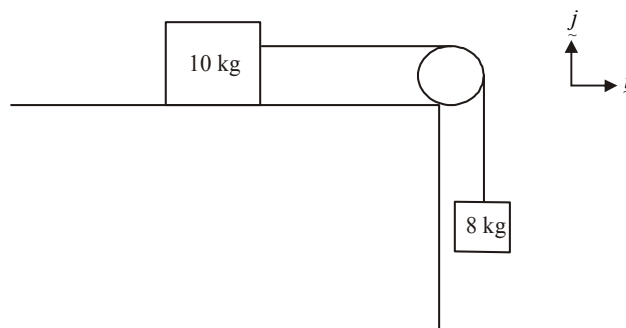
Question 22

A mass of 10kg sits on a horizontal surface and is attached to a light string which passes over a smooth pulley and has its other end attached to a mass of 8kg as shown in the diagram above.

The coefficient of friction between the 10kg mass and the horizontal surface is 0.1.

A horizontal force of 50N acts on the 10kg mass in the $-i$ direction.

The 8kg mass has an acceleration of

- A. zero
- B. $\frac{7g - 50}{18}$ m/s² downwards
- C. $\frac{7g - 50}{10}$ m/s² downwards
- D. $\frac{7g - 50}{18}$ m/s² upwards
- E. $\frac{7g - 50}{10}$ m/s² upwards

SECTION 2**Question 1**

Point A has position vector $\underline{a} = m\underline{i} + 2\underline{j}$, point B has position vector $\underline{b} = \underline{i} + 6\underline{j}$, point C has position vector $\underline{c} = n\underline{i} + 6\underline{j}$ and point D has position vector $\underline{d} = 3\underline{i} + 2\underline{j}$ relative to the origin O , where m and n are real numbers.

- a. Find \overrightarrow{AB} and \overrightarrow{AD} in terms of m .

1 mark

- b. Hence use a vector method to find the values of m and n such that $ABCD$ is a rhombus.

3 marks

- c. Show that \vec{AC} is perpendicular to \vec{BD} .

2 marks

- d. Find \vec{AE} , the vector resolute of \vec{AB} parallel to \vec{AD} .

2 marks

- e. Let θ° be the angle between vector \vec{AB} and vector \vec{AD} where $\theta < 90^\circ$.
Use a vector method to find $\cos(\theta^\circ)$.

2 marks

- f. Find an expression for $\cos(180 - \theta)^\circ$ and hence find the angle between \vec{BA} and \vec{BC} . Express your answer to the nearest minute.

3 marks
Total 13 marks

Question 2

At an aquatic fun park, Rhiannon slides down a straight water slide that is 15 metres long and inclined at an angle of 45° to the horizontal, Rhiannon has a mass of 40kg. The coefficient of friction between Rhiannon and the slide is 0.1 and the end of the slide is 3 metres vertically above the water.

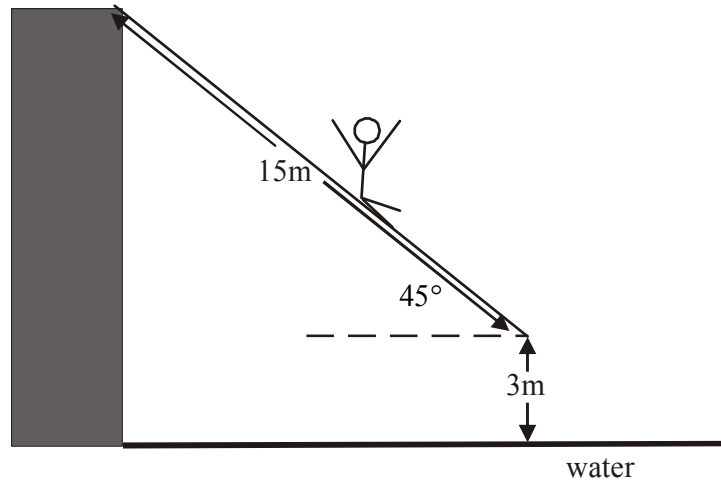

- a. Show clearly the forces acting on Rhiannon on the diagram above.

1 mark

- b. Show that the acceleration, a in m/s^2 , of Rhiannon down the slide is given by $\frac{9\sqrt{2}g}{20}$.

3 marks

- c. Using the equation of motion of a person sliding down the slide, and assuming that the coefficient of friction is still 0.1, show that $a = \frac{9\sqrt{2}g}{20} \text{ m/s}^2$ regardless of the person's mass.

2 marks

- d. Given that Rhiannon starts from rest at the top of the slide, find correct to 2 decimal places, the total time she is on the slide.

2 marks

- e. Show that Rhiannon's speed at the end of the slide is 13.68 m/s (correct to 2 decimal places).

1 mark

- f.** Find how long Rhiannon is in “freefall” between leaving the end of the slide and landing in the water. Express your answer in seconds correct to 2 decimal places.

3 marks

- g.** Find the angle at which Rhiannon enters the water.

2 marks

Total 14 marks

Question 3

An object moving in a plane has a position vector given by $\underline{r} = x(t)\underline{i} + y(t)\underline{j}$, $t > 0$ and an

acceleration vector given by $\underline{\ddot{r}} = \frac{a}{t^2}\underline{i} - \frac{t}{(a^2 - t^2)^{\frac{3}{2}}}\underline{j}$, where $t > 0$ and a is a positive constant.

- a.** **i.** Using the substitution $u = a^2 - t^2$, write down an integral which gives $y(t)$ in terms of the variable u .

- ii.** Hence show that $\dot{y}(t) = \frac{-1}{\sqrt{a^2 - t^2}}$ given that $\dot{y}(1) = \frac{-1}{\sqrt{a^2 - 1}}$.

2+1=3 marks

- b.** Find $y(t)$ given that $y\left(\frac{a}{2}\right) = \frac{\pi}{3}$.

1 mark

- c. Verify that $x = -a \log_e(t)$ is a solution to the differential equation

$$t^2 \frac{d^2x}{dt^2} = a(1-t) - t^2 \frac{dx}{dt}, \quad t > 0$$

where a is a positive constant.

2 marks

- d. Write down an expression for r in terms of the variable t by

- using your working from part c. and
- using the fact that $x(1) = 0$ and
- not using further calculus.

2 marks

- e. Hence find the Cartesian equation of the object.

1 mark
Total 9 marks

Question 4

The complex number $z = r\text{cis}(\theta)$ is shown on the Argand diagram below.

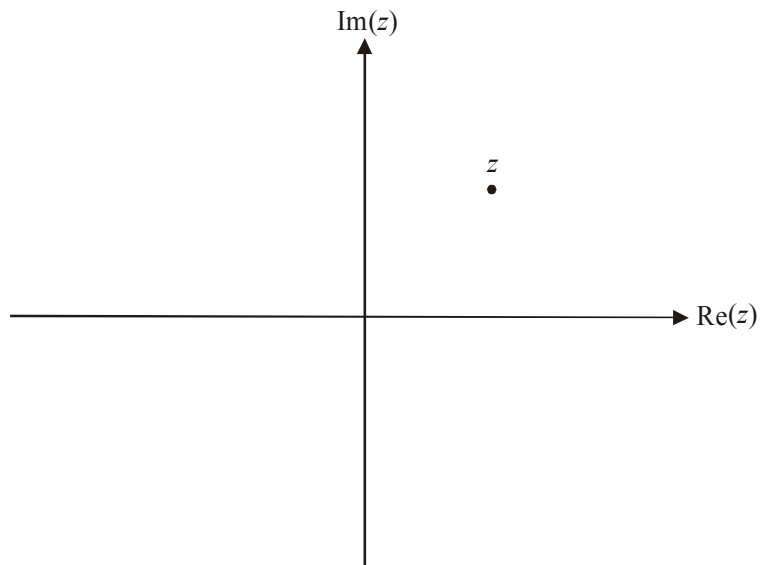

a. i. Plot \bar{z} ; the complex conjugate of z on the diagram above.

ii. Hence find $\text{Arg}(\bar{z})$.

iii. Express \bar{z} in polar form.

iv. Show that $(\bar{z})^n = \overline{(z^n)}$ where n is an integer.

1 + 1 + 1 + 2 = 5 marks

- b. Show that $z^n + (\bar{z})^n = 2r^n \cos(n\theta)$.

2 marks

- c. Hence show that $(1+i)^{12} + (1-i)^{12} = -128$.

2 marks

- d. Sketch the region enclosed by $\{z : \operatorname{Re}(z) > (1+i)^{12} + (1-i)^{12}\} \cap \{z : |z| \leq 128\}$ on the set of axes below.

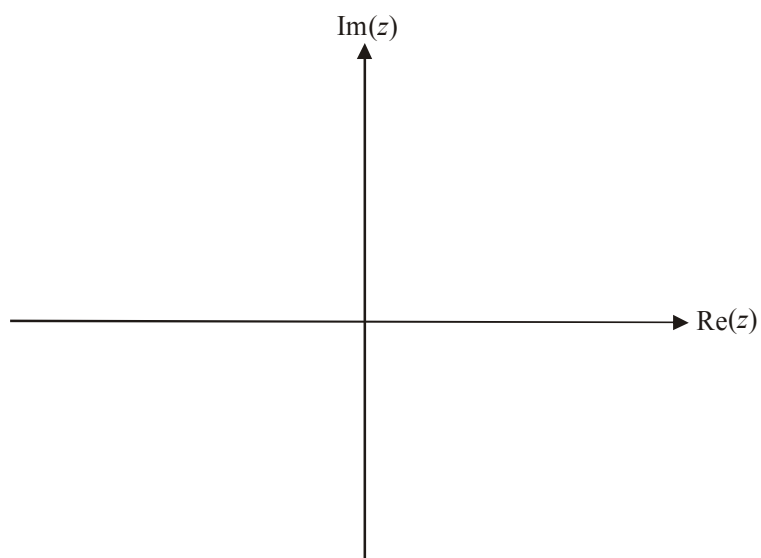

2 marks
Total 11 marks

Question 5

- a. On the set of axes below, sketch the graph of the relation $16(y + 0.1)^2 + 9x^2 = 1.44$. It is not necessary to show the x - intercepts on your graph.

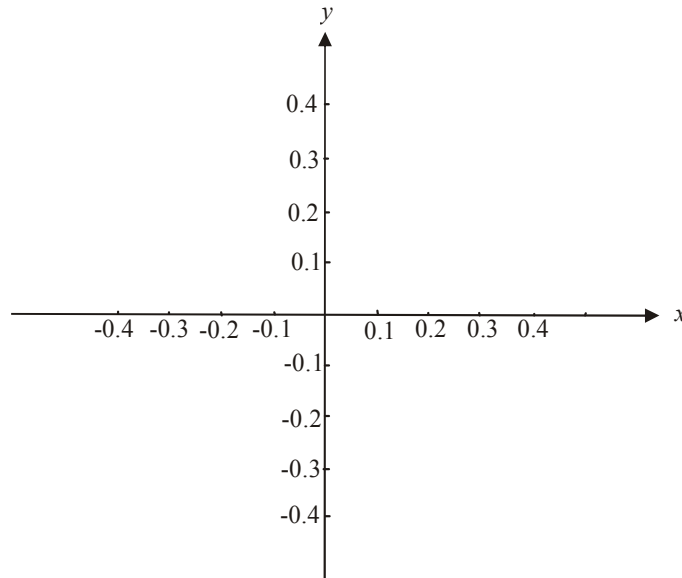

2 marks

That part of the relation for which $x \geq 0$ and $0 \leq y \leq 0.2$ is rotated about the y -axis to form a volume of revolution which models the base for a beach umbrella.

- b. Write down a definite integral which represents the volume $V \text{ m}^3$, of the base given that x and y are measured in metres.

2 marks

- c. Find the volume of the base in m^3 correct to 4 decimal places.

1 mark

The base for the beach umbrella is hollow and can be filled with water. The base sits on a decking and contains 50 litres of fresh water.

The base is moved a short distance along the decking and as a result starts leaking from underneath at the rate of 0.5litre/minute. At the same time, sea water is added to the base at the same rate.

Let S be the number of grams of salt in the base t minutes after the seawater started to be added. The salt concentration in the sea water is 35grams /litre.

- d. i.** Show that, the rate at which the amount of salt in the base changes over time, is given by $\frac{dS}{dt} = \frac{1750 - S}{100}$ g/min assuming that the concentration of salt in the base is kept uniform.

- ii.** Use calculus to find an expression for the time t , in terms of S .

- iii.** If sea water was continued to be added at the same rate indefinitely and the leak continued at the same rate indefinitely, explain what would happen to the amount of salt in the base over the long term.

2 + 2 + 2 = 6 marks

Total 11 marks

Specialist Mathematics Formulas

Mensuration

area of a trapezium:	$\frac{1}{2}(a+b)h$
curved surface area of a cylinder:	$2\pi rh$
volume of a cylinder:	$\pi r^2 h$
volume of a cone:	$\frac{1}{3}\pi r^2 h$
volume of a pyramid:	$\frac{1}{3}Ah$
volume of a sphere:	$\frac{4}{3}\pi r^3$
area of a triangle:	$\frac{1}{2}bc \sin A$
sine rule:	$\frac{a}{\sin A} = \frac{b}{\sin B} = \frac{c}{\sin C}$
cosine rule:	$c^2 = a^2 + b^2 - 2ab \cos C$

Coordinate geometry

ellipse: $\frac{(x-h)^2}{a^2} + \frac{(y-k)^2}{b^2} = 1$ hyperbola: $\frac{(x-h)^2}{a^2} - \frac{(y-k)^2}{b^2} = 1$

Circular (trigonometric) functions

$$\cos^2(x) + \sin^2(x) = 1$$

$$1 + \tan^2(x) = \sec^2(x)$$

$$\sin(x+y) = \sin(x)\cos(y) + \cos(x)\sin(y)$$

$$\cos(x+y) = \cos(x)\cos(y) - \sin(x)\sin(y)$$

$$\tan(x+y) = \frac{\tan(x) + \tan(y)}{1 - \tan(x)\tan(y)}$$

$$\cos(2x) = \cos^2(x) - \sin^2(x) = 2\cos^2(x) - 1 = 1 - 2\sin^2(x)$$

$$\sin(2x) = 2\sin(x)\cos(x)$$

$$\cot^2(x) + 1 = \operatorname{cosec}^2(x)$$

$$\sin(x-y) = \sin(x)\cos(y) - \cos(x)\sin(y)$$

$$\cos(x-y) = \cos(x)\cos(y) + \sin(x)\sin(y)$$

$$\tan(x-y) = \frac{\tan(x) - \tan(y)}{1 + \tan(x)\tan(y)}$$

$$\tan(2x) = \frac{2\tan(x)}{1 - \tan^2(x)}$$

function	\sin^{-1}	\cos^{-1}	\tan^{-1}
domain	$[-1, 1]$	$[-1, 1]$	R
range	$\left[-\frac{\pi}{2}, \frac{\pi}{2}\right]$	$[0, \pi]$	$\left(-\frac{\pi}{2}, \frac{\pi}{2}\right)$

Algebra (Complex numbers)

$$z = x + yi = r(\cos \theta + i \sin \theta) = r \operatorname{cis} \theta$$

$$|z| = \sqrt{x^2 + y^2} = r$$

$$z_1 z_2 = r_1 r_2 \operatorname{cis}(\theta_1 + \theta_2)$$

$$z^n = r^n \operatorname{cis}(n\theta) \quad (\text{de Moivre's theorem})$$

$$-\pi < \operatorname{Arg} z \leq \pi$$

$$\frac{z_1}{z_2} = \frac{r_1}{r_2} \operatorname{cis}(\theta_1 - \theta_2)$$

Reproduced with permission of the Victorian Curriculum and Assessment Authority, Victoria, Australia.

*This formula sheet has been copied in 2007 from the VCAA website www.vcaa.vic.edu.au
The VCAA publish an exam issue supplement to the VCAA bulletin.*

Calculus

$$\frac{d}{dx}(x^n) = nx^{n-1}$$

$$\frac{d}{dx}(e^{ax}) = ae^{ax}$$

$$\frac{d}{dx}(\log_e(x)) = \frac{1}{x}$$

$$\frac{d}{dx}(\sin(ax)) = a \cos(ax)$$

$$\frac{d}{dx}(\cos(ax)) = -a \sin(ax)$$

$$\frac{d}{dx}(\tan(ax)) = a \sec^2(ax)$$

$$\frac{d}{dx}(\sin^{-1}(x)) = \frac{1}{\sqrt{1-x^2}}$$

$$\frac{d}{dx}(\cos^{-1}(x)) = \frac{-1}{\sqrt{1-x^2}}$$

$$\frac{d}{dx}(\tan^{-1}(x)) = \frac{1}{1+x^2}$$

$$\int x^n dx = \frac{1}{n+1} x^{n+1} + c, n \neq -1$$

$$\int e^{ax} dx = \frac{1}{a} e^{ax} + c$$

$$\int \frac{1}{x} dx = \log_e|x| + c$$

$$\int \sin(ax) dx = -\frac{1}{a} \cos(ax) + c$$

$$\int \cos(ax) dx = \frac{1}{a} \sin(ax) + c$$

$$\int \sec^2(ax) dx = \frac{1}{a} \tan(ax) + c$$

$$\int \frac{1}{\sqrt{a^2-x^2}} dx = \sin^{-1}\left(\frac{x}{a}\right) + c, a > 0$$

$$\int \frac{-1}{\sqrt{a^2-x^2}} dx = \cos^{-1}\left(\frac{x}{a}\right) + c, a > 0$$

$$\int \frac{a}{a^2+x^2} dx = \tan^{-1}\left(\frac{x}{a}\right) + c$$

product rule:

$$\frac{d}{dx}(uv) = u \frac{dv}{dx} + v \frac{du}{dx}$$

quotient rule:

$$\frac{d}{dx}\left(\frac{u}{v}\right) = \frac{v \frac{du}{dx} - u \frac{dv}{dx}}{v^2}$$

chain rule:

$$\frac{dy}{dx} = \frac{dy}{du} \frac{du}{dx}$$

Euler's method:

$$\text{If } \frac{dy}{dx} = f(x), x_0 = a \text{ and } y_0 = b,$$

$$\text{then } x_{n+1} = x_n + h \text{ and } y_{n+1} = y_n + hf(x_n)$$

acceleration:

$$a = \frac{d^2x}{dt^2} = \frac{dv}{dt} = v \frac{dv}{dx} = \frac{d}{dx}\left(\frac{1}{2}v^2\right)$$

$$\text{constant (uniform) acceleration: } v = u + at \quad s = ut + \frac{1}{2}at^2 \quad v^2 = u^2 + 2as \quad s = \frac{1}{2}(u+v)t$$

Reproduced with permission of the Victorian Curriculum and Assessment Authority, Victoria, Australia.

*This formula sheet has been copied in 2007 from the VCAA website www.vcaa.vic.edu.au
The VCAA publish an exam issue supplement to the VCAA bulletin.*

Vectors in two and three dimensions

$$\underline{r} = x \underline{i} + y \underline{j} + z \underline{k}$$

$$|\underline{r}| = \sqrt{x^2 + y^2 + z^2} = r$$

$$\underline{r}_1 \cdot \underline{r}_2 = r_1 r_2 \cos \theta = x_1 x_2 + y_1 y_2 + z_1 z_2$$

$$\dot{\underline{r}} = \frac{d\underline{r}}{dt} = \frac{dx}{dt} \underline{i} + \frac{dy}{dt} \underline{j} + \frac{dz}{dt} \underline{k}$$

Mechanics

momentum: $\underline{p} = m \underline{v}$

equation of motion: $\underline{R} = m \underline{a}$

friction: $F \leq \mu N$

Reproduced with permission of the Victorian Curriculum and Assessment Authority, Victoria, Australia.

*This formula sheet has been copied in 2007 from the VCAA website www.vcaa.vic.edu.au
The VCAA publish an exam issue supplement to the VCAA bulletin.*

SPECIALIST MATHEMATICS

TRIAL EXAMINATION 2

MULTIPLE- CHOICE ANSWER SHEET

STUDENT NAME:.....

INSTRUCTIONS

Fill in the letter that corresponds to your choice. Example: A B C D E

The answer selected is B. Only one answer should be selected.

- | | |
|--|--|
| 1. <input type="checkbox"/> A <input type="checkbox"/> B <input type="checkbox"/> C <input type="checkbox"/> D <input type="checkbox"/> E | 12. <input type="checkbox"/> A <input type="checkbox"/> B <input type="checkbox"/> C <input type="checkbox"/> D <input type="checkbox"/> E |
| 2. <input type="checkbox"/> A <input type="checkbox"/> B <input type="checkbox"/> C <input type="checkbox"/> D <input type="checkbox"/> E | 13. <input type="checkbox"/> A <input type="checkbox"/> B <input type="checkbox"/> C <input type="checkbox"/> D <input type="checkbox"/> E |
| 3. <input type="checkbox"/> A <input type="checkbox"/> B <input type="checkbox"/> C <input type="checkbox"/> D <input type="checkbox"/> E | 14. <input type="checkbox"/> A <input type="checkbox"/> B <input type="checkbox"/> C <input type="checkbox"/> D <input type="checkbox"/> E |
| 4. <input type="checkbox"/> A <input type="checkbox"/> B <input type="checkbox"/> C <input type="checkbox"/> D <input type="checkbox"/> E | 15. <input type="checkbox"/> A <input type="checkbox"/> B <input type="checkbox"/> C <input type="checkbox"/> D <input type="checkbox"/> E |
| 5. <input type="checkbox"/> A <input type="checkbox"/> B <input type="checkbox"/> C <input type="checkbox"/> D <input type="checkbox"/> E | 16. <input type="checkbox"/> A <input type="checkbox"/> B <input type="checkbox"/> C <input type="checkbox"/> D <input type="checkbox"/> E |
| 6. <input type="checkbox"/> A <input type="checkbox"/> B <input type="checkbox"/> C <input type="checkbox"/> D <input type="checkbox"/> E | 17. <input type="checkbox"/> A <input type="checkbox"/> B <input type="checkbox"/> C <input type="checkbox"/> D <input type="checkbox"/> E |
| 7. <input type="checkbox"/> A <input type="checkbox"/> B <input type="checkbox"/> C <input type="checkbox"/> D <input type="checkbox"/> E | 18. <input type="checkbox"/> A <input type="checkbox"/> B <input type="checkbox"/> C <input type="checkbox"/> D <input type="checkbox"/> E |
| 8. <input type="checkbox"/> A <input type="checkbox"/> B <input type="checkbox"/> C <input type="checkbox"/> D <input type="checkbox"/> E | 19. <input type="checkbox"/> A <input type="checkbox"/> B <input type="checkbox"/> C <input type="checkbox"/> D <input type="checkbox"/> E |
| 9. <input type="checkbox"/> A <input type="checkbox"/> B <input type="checkbox"/> C <input type="checkbox"/> D <input type="checkbox"/> E | 20. <input type="checkbox"/> A <input type="checkbox"/> B <input type="checkbox"/> C <input type="checkbox"/> D <input type="checkbox"/> E |
| 10. <input type="checkbox"/> A <input type="checkbox"/> B <input type="checkbox"/> C <input type="checkbox"/> D <input type="checkbox"/> E | 21. <input type="checkbox"/> A <input type="checkbox"/> B <input type="checkbox"/> C <input type="checkbox"/> D <input type="checkbox"/> E |
| 11. <input type="checkbox"/> A <input type="checkbox"/> B <input type="checkbox"/> C <input type="checkbox"/> D <input type="checkbox"/> E | 22. <input type="checkbox"/> A <input type="checkbox"/> B <input type="checkbox"/> C <input type="checkbox"/> D <input type="checkbox"/> E |