

**THE
HEFFERNAN
GROUP**

P.O. Box 1180
Surrey Hills North VIC 3127
ABN 20 607 374 020
Phone 9836 5021
Fax 9836 5025

Student Name:

SPECIALIST MATHEMATICS

TRIAL EXAMINATION 1

(FACTS, SKILLS AND APPLICATIONS TASK)

2004

Reading Time: 15 minutes
Writing time: 90 minutes

Instructions to students

This exam consists of Part I and Part II.
Part I consists of 30 multiple-choice questions and should be answered on the detachable answer sheet on page 24 of this exam. This section of the paper is worth 30 marks.
Part II consists of 5 short-answer questions, all of which should be answered in the spaces provided. Part II begins on page 16 of this exam. This section of the paper is worth 20 marks.
There is a total of 50 marks available.
The acceleration due to gravity should be taken to have magnitude $g \text{ m/s}^2$ where $g = 9.8$
Students may bring up to two A4 pages of pre-written notes into the exam.
Formula sheets can be found on pages 21-23 of this exam.
Diagrams in this exam are not to scale except where otherwise stated.

This paper has been prepared independently of the Victorian Curriculum and Assessment Authority to provide additional exam preparation for students. Although references have been reproduced with permission of the Victorian Curriculum and Assessment Authority the publication is in no way connected with or endorsed by the Victorian Curriculum and Assessment Authority.

© THE HEFFERNAN GROUP 2004

This Trial Exam is licensed on a non transferable basis to the purchaser. It may be copied for educational use within the school which has purchased it. This license does not permit distribution or copying of this Trial Exam outside that school or by any individual purchaser.

PART I**Question 1**

If $f(x) = 3x^2 + \frac{5}{x}$, then the graph of $y = f(x)$

- A. has an x -intercept at $x = -1$
- B. has a local maximum at $(1, 8)$
- C. is not defined for $y < 0$
- D. has no y -intercept
- E. has asymptotes at $x = 0$ and $y = 0$

Question 2

The graph of the relation with equation $\frac{y^2}{16} - \frac{x^2}{25} = 1$ intersects the

- A. the x -axis once
- B. the x -axis twice
- C. the y -axis once
- D. the y -axis twice
- E. x and y axes twice.

Question 3

The gradient of the graph of $y = \text{Cos}^{-1}\left(\frac{x}{2}\right)$ at $x = 0$ is

- A. $-\frac{1}{4}$
- B. $-\frac{1}{2}$
- C. 0
- D. $\frac{1}{4}$
- E. $\frac{1}{2}$

Question 4

If $\sin(x) = \frac{-1}{3}$ and $\frac{3\pi}{2} \leq x \leq 2\pi$ then $\sec(x)$ equals

- A. $\frac{-3\sqrt{6}}{4}$
- B. $\frac{-3}{2}$
- C. $\frac{\sqrt{3}}{2}$
- D. $\frac{3}{2}$
- E. $\frac{3\sqrt{2}}{4}$

Question 5

If $u = 2 - i$ and $v = \bar{u} + 1$ then $\frac{u}{v}$ is equal to

- A. $\frac{1}{2} - \frac{i}{2}$
- B. $\frac{1}{2} + \frac{i}{2}$
- C. $\frac{3}{5} - \frac{i}{2}$
- D. $\frac{3}{4} + \frac{i}{4}$
- E. $1 - \frac{i}{2}$

Question 6

A polar form of the complex number $\sqrt{3} - i$ is

- A. $2\text{cis}\left(-\frac{13\pi}{6}\right)$
- B. $2\text{cis}\left(\frac{\pi}{6}\right)$
- C. $2\text{cis}\left(\frac{\pi}{3}\right)$
- D. $2\text{cis}\left(-\frac{\pi}{3}\right)$
- E. $4\text{cis}\left(\frac{-\pi}{6}\right)$

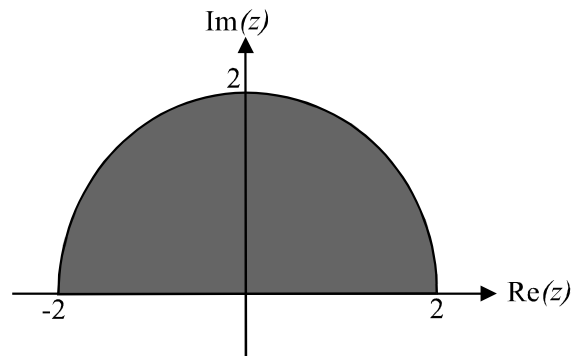
Question 7

The shaded region, with boundaries included, shown above on an Argand diagram could be described by

- A. $\left\{z : \frac{1}{2}|z| \leq 2\right\}$
- B. $\{z : |z| \leq 2\} \cap \{z : \text{Im}(z) > 0\}$
- C. $\{z : |z| \leq 2\} \cap \{z : \text{Im}(z) \geq 0\}$
- D. $\{z : |z| \leq 4\} \cap \{z : \text{Im}(z) \geq 0\}$
- E. $\{z : |z| \leq 4\} \cap \{z : 0 \leq \text{Arg}(z) \leq \pi\}$

Question 8

If $P(z)$ is a cubic polynomial with real coefficients and one of its factors is $(z - 1 - i)$ then which one of the following could be a solution of the equation $P(z) = 0$?

- A. 3
- B. $-1 - i$
- C. $-1 + i$
- D. $z - 2$
- E. $z - 1 + i$

Question 9

The solutions of the equation $z^3 = \text{cis}\left(\frac{\pi}{2}\right)$ are

- A. $\frac{\pi}{6}, \frac{5\pi}{6}, \frac{3\pi}{2}$
 B. $\pm \text{cis}\left(\sqrt[3]{\frac{\pi}{2}}\right)$
 C. $\text{cis}\left(\frac{\pi}{6}\right)$
 D. $\text{cis}\left(\frac{\pi}{6}\right), \text{cis}\left(\frac{\pi}{3}\right), \text{cis}\left(\frac{2\pi}{3}\right)$
 E. $\text{cis}\left(\frac{-\pi}{2}\right), \text{cis}\left(\frac{\pi}{6}\right), \text{cis}\left(\frac{5\pi}{6}\right)$

Question 10

An antiderivative of $\frac{x}{\sqrt{3-x}}$ is

- A. $\frac{x^2}{\sqrt{2(6-x^2)}}$
 B. $-4\sqrt{3-x}$
 C. $3(3-x) - \frac{2}{3}(3-x)^{\frac{3}{2}}$
 D. $6(3-x)^{\frac{1}{2}} - \frac{2}{3}(3-x)^{\frac{3}{2}}$
 E. $\frac{2}{3}(3-x)^{\frac{3}{2}} - 6(3-x)^{\frac{1}{2}}$

Question 11

If $\frac{dy}{dx} = \frac{-2}{\sqrt{4-x^2}}$, then y is equal to

- A. $-2\text{Cos}^{-1}\left(\frac{x}{2}\right) + c$
- B. $-\frac{1}{2}\text{Cos}^{-1}\left(\frac{x}{2}\right) + c$
- C. $-\frac{1}{2}\text{Sin}^{-1}\left(\frac{x}{2}\right) + c$
- D. $2\text{Cos}^{-1}\left(\frac{x}{2}\right) + c$
- E. $2\text{Sin}^{-1}\left(\frac{x}{2}\right) + c$

Question 12

The value of $\int_{-2}^1 \sqrt{9-x^2} dx$, correct to four decimal places is

- A. 1.0696
- B. 3.9998
- C. 5.2317
- D. 8.4633
- E. 8.4497

Question 13

If $f'(x) = \sin^2(3x)$ and $f\left(\frac{\pi}{6}\right) = \frac{\pi}{12}$ then $f(x)$ is equal to

- A. $x - \frac{1}{6}\sin(6x) - \frac{\pi}{12}$
- B. $-x + \frac{1}{6}\sin(6x) + \frac{\pi}{4}$
- C. $\frac{x}{2} - \frac{1}{12}\sin(6x)$
- D. $\frac{x}{2} - \frac{1}{12}\sin(6x) - \frac{\pi}{6}$
- E. $-\frac{1}{3} - \frac{\pi}{12} + \frac{1}{3}\sin^3(3x)$

Question 14

If $y = \log_e(e^{2x})$, then

- A. $\frac{d^2y}{dx^2} = 2x - \frac{dy}{dx}$
- B. $\frac{d^2y}{dx^2} = \frac{dy}{dx} - 2$
- C. $\frac{d^2y}{dx^2} = \frac{dy}{dx} - y$
- D. $\frac{d^2y}{dx^2} = 2 \frac{dy}{dx}$
- E. $\frac{d^2y}{dx^2} = \frac{1}{2} \frac{dy}{dx}$

Question 15

The diagram shows the graphs of $y = \cos(2x)$ and $y = 2 \cos(2x)$ for $-\frac{\pi}{4} \leq x \leq \frac{5\pi}{4}$.

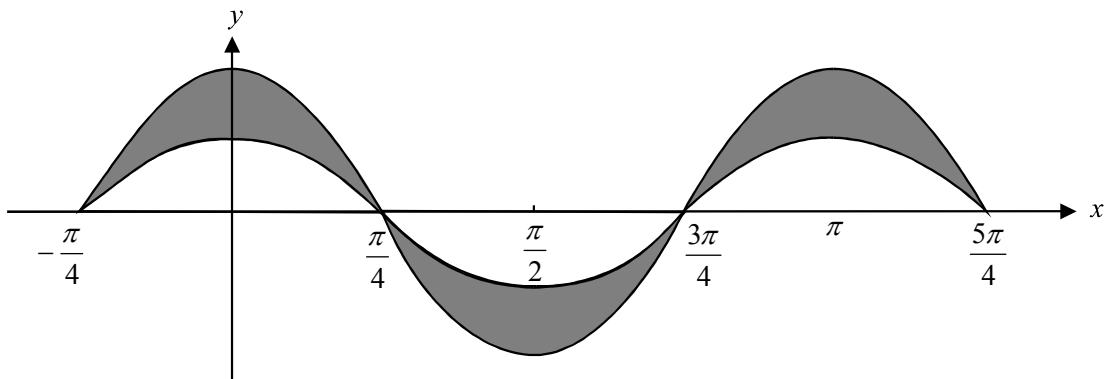

The total area in square units of the shaded region enclosed by the two graphs is

- A. $2 \int_0^{\frac{\pi}{4}} \cos(2x) dx$
- B. $6 \int_0^{\frac{\pi}{4}} \cos(2x) dx$
- C. $\int_{\frac{3\pi}{4}}^{\frac{5\pi}{4}} \cos(2x) dx$
- D. $\int_{-\frac{\pi}{4}}^{\frac{\pi}{4}} \cos(2x) dx + \int_{\frac{\pi}{4}}^{\frac{3\pi}{4}} \cos(2x) dx + \int_{\frac{3\pi}{4}}^{\frac{5\pi}{4}} \cos(2x) dx$
- E. $2 \int_0^{\frac{\pi}{4}} \cos(2x) dx + 2 \int_{\frac{\pi}{4}}^{\frac{\pi}{2}} \cos(2x) dx + 2 \int_{\frac{3\pi}{4}}^{\pi} \cos(2x) dx$

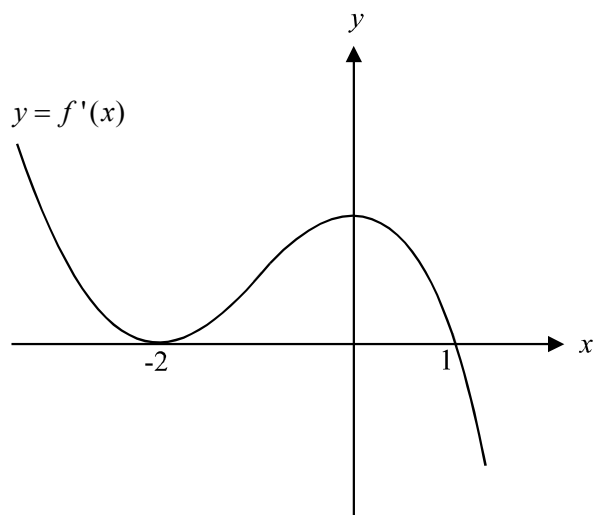
Question 16

The graph of $y = f'(x)$ is shown above.

From this graph we know that the graph of $y = f(x)$ has

- A. a local minimum at $x = -2$ and a local maximum at $x = 0$
- B. a local minimum at $x = -2$ and a point of inflection at $x = 0$
- C. a stationary point of inflection at $x = -2$ and a local maximum at $x = 1$
- D. a stationary point of inflection at $x = 0$
- E. a point of inflection at $x = -2$ and $x = 1$.

Question 17

An approximate solution to the differential equation $\frac{dy}{dx} = \log_e(2x + 1)$ is found using Euler's method with a step size of 0.1 and with $y = 0$ at $x = 0$.

When $x = 0.2$ the value obtained for y would be

- A. $\frac{\log_e(1)}{10}$
- B. $\frac{\log_e(1.2)}{10}$
- C. $\frac{1 + \log_e(1.2)}{10}$
- D. $\log_e(0.1)$
- E. $\log_e(1.2)$

Question 18

Fertilizer is **released** from a dispenser at the constant rate of $10 \text{ cm}^3 / \text{min}$.

The dispenser is in the shape of an inverted square pyramid with a vertical height of 40cm and a sidelength of 80cm as shown in the diagram below.

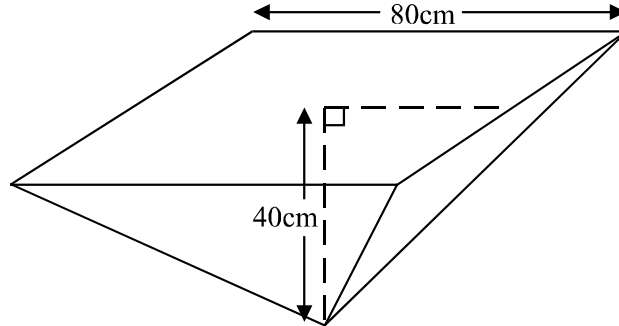

The rate at which the height, h , of the fertilizer remaining in the dispenser is changing in cm/min is given by

- A. $\frac{-40}{h^2}$
- B. $\frac{-10}{h^2}$
- C. $\frac{-5}{2h^2}$
- D. $\frac{5}{2h^2}$
- E. $\frac{40}{h^2}$

Question 19

A particle moves in a straight line with velocity, v , and displacement, x , from a fixed origin O. Its acceleration is given by $v(2v + 1)$ and its velocity is 1 m/s as it passes through O.

Its displacement from the origin in terms of v is given by

- A. $2v + 1$
- B. $\frac{2v + 1}{3}$
- C. $\frac{1}{2} \log_e (2v + 1)$
- D. $\frac{1}{2} \log_e \left(\frac{2v + 1}{3} \right)$
- E. $\frac{1}{2} \log_e (3(2v + 1))$

Question 20

The position vectors of points P and Q are respectively $3\mathbf{i} + 2\mathbf{j} - \mathbf{k}$ and $2\mathbf{i} + \mathbf{j} - \mathbf{k}$. The magnitude of \vec{PQ} is

- A. 1
- B. $\sqrt{2}$
- C. 2
- D. $\sqrt{34}$
- E. $\sqrt{38}$

Question 21

A surveyor leaves his base point at O and walks to a point P on a bearing of $N30^\circ E$ for 100m on land that has a gradient of $\frac{5}{12}$. Let \mathbf{i} and \mathbf{j} be the unit vectors of magnitude 1m in the east and north directions respectively and \mathbf{k} is the unit vector of magnitude 1m vertically up.

The position vector \vec{OP} is

- A. $50\sqrt{3}\mathbf{i} + 50\mathbf{j} + \frac{500}{13}\mathbf{k}$
- B. $50\mathbf{i} + 50\sqrt{3}\mathbf{j} + \frac{500}{13}\mathbf{k}$
- C. $\frac{500}{\sqrt{3}}\mathbf{i} + \frac{50}{\sqrt{3}}\mathbf{j} + \frac{5}{13}\mathbf{k}$
- D. $\frac{600}{13}\mathbf{i} + \frac{600\sqrt{3}}{13}\mathbf{j} + \frac{500}{13}\mathbf{k}$
- E. $\frac{13}{2400}\mathbf{i} + \frac{13\sqrt{3}}{2400}\mathbf{j} + \frac{500}{13}\mathbf{k}$

Question 22

Let $\mathbf{u} = n\mathbf{i}$ and $\mathbf{v} = \mathbf{i} - \mathbf{j}$ where n is a constant.

The angle between \mathbf{u} and \mathbf{v} is

- A. $\frac{\pi^c}{6}$
- B. $\frac{\pi^c}{3}$
- C. $\frac{\pi^c}{4}$
- D. $\frac{\pi^c}{2}$
- E. $\frac{3\pi^c}{4}$

Question 23

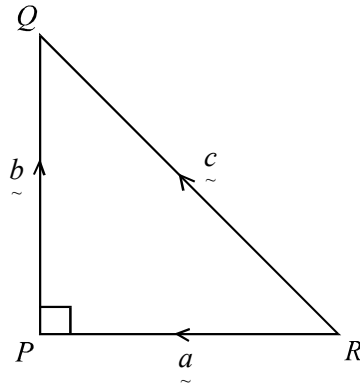

Triangle PQR , is a right angled isosceles triangle with $\vec{RP} = \underline{a}$, $\vec{PQ} = \underline{b}$ and $\vec{RQ} = \underline{c}$.

Which one of the following is not true?

- A. $\underline{a} \cdot \underline{b} = 0$
- B. $\underline{a} + \underline{b} = \underline{c}$
- C. $\underline{a} \cdot \underline{a} + \underline{b} \cdot \underline{b} = \underline{c} \cdot \underline{c}$
- D. $(\underline{a} - \underline{b}) \cdot (\underline{a} + \underline{b}) = 1$
- E. $|\underline{a}| + |\underline{b}| > |\underline{c}|$

Question 24

The vector resolute of $2\underline{i} + \underline{j} - \underline{k}$ perpendicular to $-\underline{i} + 2\underline{j} + \underline{k}$ is

- A. $\frac{1}{\sqrt{6}}(-\underline{i} + 2\underline{j} + \underline{k})$
- B. $\frac{-1}{\sqrt{6}}(-\underline{i} + 2\underline{j} + \underline{k})$
- C. $\frac{1}{6}(-\underline{i} + 2\underline{j} + \underline{k})$
- D. $\frac{1}{6}(11\underline{i} + 8\underline{j} - 5\underline{k})$
- E. $\frac{1}{6}(13\underline{i} + 4\underline{j} - 7\underline{k})$

Question 25

The displacement of a particle at time t seconds, $t \in [0, \frac{\pi}{2})$, is given by

$$\underline{r}(t) = \tan(t)\underline{i} + 3\underline{j} + e^{4t}\underline{k}.$$

The motion of the particle initially is in the direction of

- A. $4\underline{k}$
- B. $\underline{i} - \frac{1}{4}\underline{k}$
- C. $\underline{i} + \frac{1}{4}\underline{k}$
- D. $\underline{i} + 4\underline{k}$
- E. $3\underline{j} + \underline{k}$

Question 26

A particle of mass 4kg, started from rest and has an acceleration given by

$$\underline{a}(t) = 6t^2\underline{i} + \cos(2t)\underline{j} \quad t \geq 0.$$

The momentum of the particle is given by

- A. \underline{i}
- B. $48t\underline{i} + 8 \sin(2t)\underline{j}$
- C. $8t^3\underline{i} + 2 \sin(2t)\underline{j}$
- D. $8t^3\underline{i} + 2(\sin(2t) - 1)\underline{j}$
- E. $2t^4\underline{i} - \cos(2t)\underline{j}$

Question 27

A particle of mass 5 kg is acted on by two forces $\underline{F}_1 = -5\underline{i} + n\underline{j}$ and $\underline{F}_2 = 10\underline{i} + 5\underline{j}$ and the acceleration of the particle is $\underline{i} + 2\underline{j}$ m/s².

The value of n is

- A. -3
- B. $-\frac{5}{2}$
- C. $\frac{1}{10}$
- D. 5
- E. 10

Question 28

A box of mass 12 kg is acted on by a force of 5 newton acting at an angle of 30° to the horizontal but is not on the point of moving across a rough table with coefficient of friction of 0.8. The normal force of the table acting on the box is N and the friction forces are given by Fr .

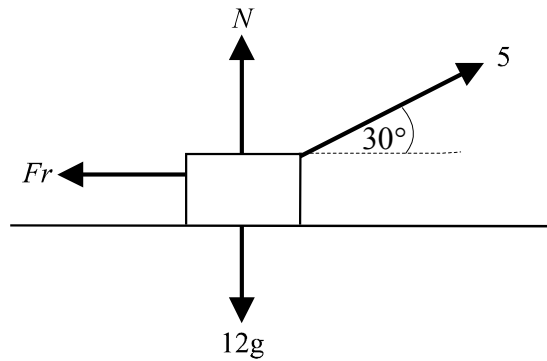

Which one of the following statements is true?

- A. $Fr < \frac{5\sqrt{3}}{2}$
- B. $N = 12g - \frac{5\sqrt{3}}{2}$
- C. $Fr = \frac{5}{2}$
- D. $Fr < 0.8N$
- E. $N = 12g + \frac{5}{2}$

Question 29

Particle A of mass m_A kg is connected to particle B of mass m_B kg and the two are on a horizontal rough surface. Particle A is acted on by a force F acting horizontally. If N_A and N_B are the normal forces acting on the particles, Fr_A and Fr_B are the friction forces, T is the tension in the connection and all forces are in Newtons, which one of the following diagrams shows correctly the forces acting on the two particles?

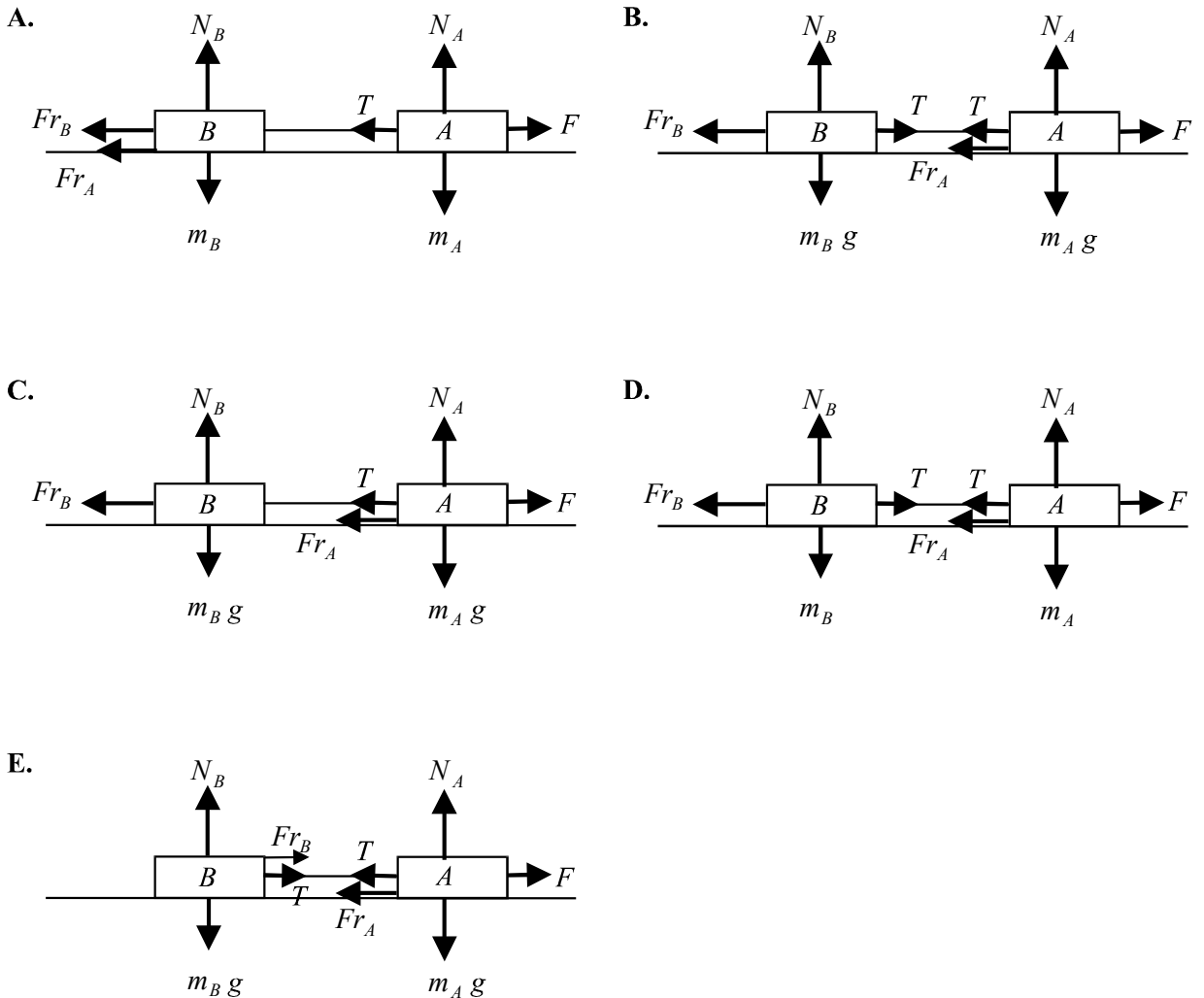

Question 30

Two boxes, one of mass 3kg and one of mass 4kg, are attached to either end of a light inextensible string that passes over a smooth pulley. The weights are initially held but then they are released.

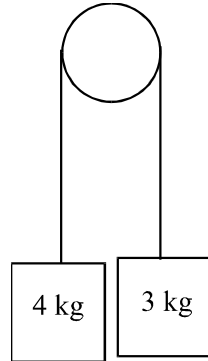

Let T be the tension in the string.

The magnitude of the acceleration of the 3kg box is given by

- A. $\frac{T - 3g}{3}$
B. $\frac{3g - T}{3}$
C. $\frac{T - 4g}{3}$
D. $\frac{7g - T}{7}$
E. $\frac{T - 7g}{3}$

PART II**Question 1**

George is travelling down a straight stretch of highway at a constant speed of 20 m/s when he is overtaken by a red car travelling at a constant speed.

Ten seconds later the red car begins to uniformly decelerate until it stops. This period of deceleration lasts for twenty seconds.

Thirty seconds after having been overtaken, George passes the stationary red car.

On the graph below, $t = 0$ represents the instant that the red car overtakes George.

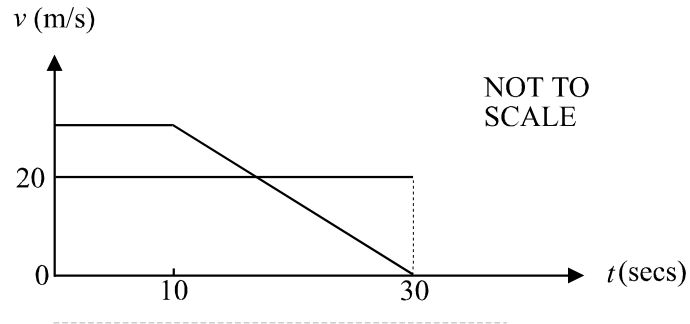

Find how fast the red car was travelling when it passed George.

2 marks

Question 2

- a. One of the solutions of the equation $z^6 - 64 = 0$, $z \in C$, is shown on the Argand diagram below. Without any calculations, indicate the other solutions on the diagram.

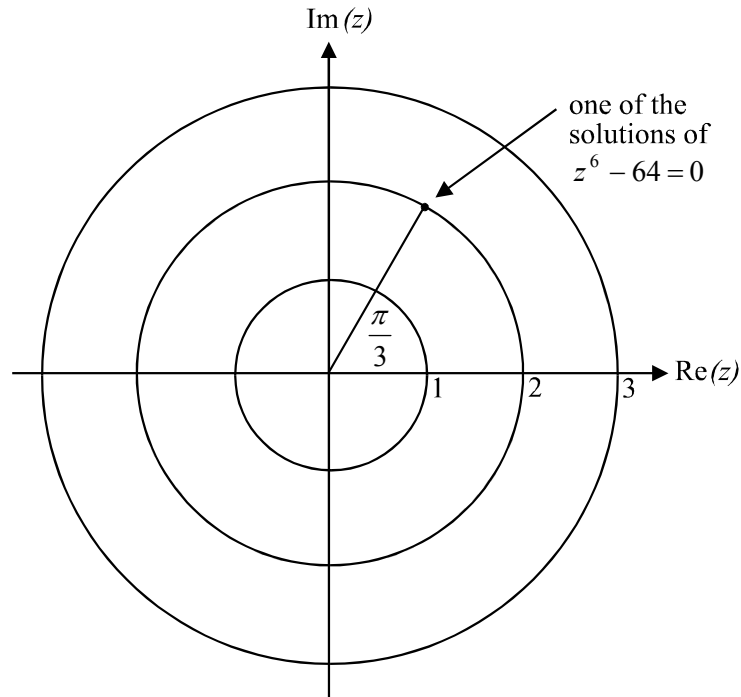

1 mark

- b. Sketch the region of the complex plane described by $\left\{z : 0 \leq \text{Arg}(z) \leq \frac{\pi}{3}\right\} \cap \{z : \text{Re}(z) < 2\}$ on the Argand diagram below.

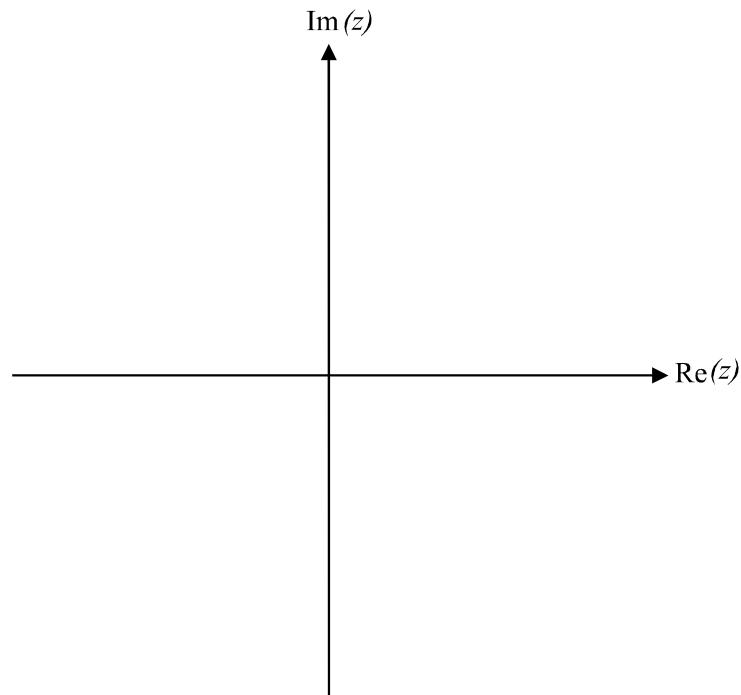

2 marks

Question 3

An object of mass 25kg rests on an inclined plane that makes an angle of 30° with the horizontal. The coefficient of friction between the particle and the plane is 0.6. The particle is connected by a light string which passes over a smooth pulley to a second object of mass x kg. The 25kg object is on the point of sliding up the inclined plane.

- a. On the diagram below, draw the forces acting on the two particles. These forces should include any gravitational forces, tension forces, normal reaction forces or frictional forces.

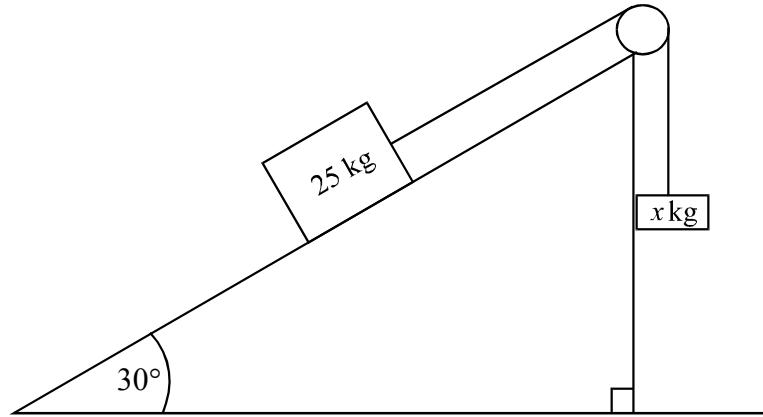

1 mark

- b. Find the value of x , expressing it correct to two decimal places.

3 marks

Question 4

- a. Solve $\sqrt{2} \sin\left(2x + \frac{\pi}{4}\right) = \cos(2x)$ for $0 \leq x \leq 2\pi$ expressing any solutions as exact values.

2 marks

- b. Evaluate $\int_0^{\frac{\pi}{6}} \sin^2(x) \cos^3(x) dx$.

4 marks

Question 5

- a.** Use the trapezoidal rule with two equal intervals to find an approximation to the area enclosed by the graph of $y = \tan(x)$, the x -axis and the line with equation $x = \frac{\pi}{3}$.

2 marks

- b.** Find the exact area enclosed by the graph of $y = \tan^{-1} x$, the y -axis and the line $y = \frac{\pi}{3}$ by using the inverse of this graph.

3 marks
Total 20 marks

Specialist Mathematics Formulas

Mensuration

area of a trapezium:	$\frac{1}{2}(a + b)h$
curved surface area of a cylinder:	$2\pi rh$
volume of a cylinder:	$\pi r^2 h$
volume of a cone:	$\frac{1}{3}\pi r^2 h$
volume of a pyramid:	$\frac{1}{3}Ah$
volume of a sphere:	$\frac{4}{3}\pi r^3$
area of a triangle:	$\frac{1}{2}bc \sin A$
sine rule:	$\frac{a}{\sin A} = \frac{b}{\sin B} = \frac{c}{\sin C}$
cosine rule:	$c^2 = a^2 + b^2 - 2ab \cos C$

Coordinate geometry

ellipse:	$\frac{(x - h)^2}{a^2} + \frac{(y - k)^2}{b^2} = 1$
hyperbola:	$\frac{(x - h)^2}{a^2} - \frac{(y - k)^2}{b^2} = 1$

Circular (trigonometric) functions

$\cos^2(x) + \sin^2(x) = 1$	
$1 + \tan^2(x) = \sec^2(x)$	$\cot^2(x) + 1 = \operatorname{cosec}^2(x)$
$\sin(x + y) = \sin(x)\cos(y) + \cos(x)\sin(y)$	$\sin(x - y) = \sin(x)\cos(y) - \cos(x)\sin(y)$
$\cos(x + y) = \cos(x)\cos(y) - \sin(x)\sin(y)$	$\cos(x - y) = \cos(x)\cos(y) + \sin(x)\sin(y)$
$\tan(x + y) = \frac{\tan(x) + \tan(y)}{1 - \tan(x)\tan(y)}$	$\tan(x - y) = \frac{\tan(x) - \tan(y)}{1 + \tan(x)\tan(y)}$
$\cos(2x) = \cos^2(x) - \sin^2(x) = 2\cos^2(x) - 1 = 1 - 2\sin^2(x)$	
$\sin(2x) = 2\sin(x)\cos(x)$	$\tan(2x) = \frac{2\tan(x)}{1 - \tan^2(x)}$

function	Sin ⁻¹	Cos ⁻¹	Tan ⁻¹
domain	[-1, 1]	[-1, 1]	R
range	$\left[-\frac{\pi}{2}, \frac{\pi}{2}\right]$	[0, π]	$\left(-\frac{\pi}{2}, \frac{\pi}{2}\right)$

Reproduced with permission of the Victorian Curriculum and Assessment Authority, Victoria, Australia.

These formula sheets have been copied from the 2003 Specialist Maths Exam 1. Teachers and students are reminded that changes to formula sheets are notified in the VCE Bulletins and on the VCAA

website at www.vcaa.vic.edu.au

The VCAA publish an exam issue supplement to the VCAA Bulletin.

Algebra (Complex numbers)

$$z = x + yi = r(\cos \theta + i \sin \theta) = r \operatorname{cis} \theta$$

$$|z| = \sqrt{x^2 + y^2} = r$$

$$-\pi < \operatorname{Arg} z \leq \pi$$

$$z_1 z_2 = r_1 r_2 \operatorname{cis}(\theta_1 + \theta_2)$$

$$\frac{z_1}{z_2} = \frac{r_1}{r_2} \operatorname{cis}(\theta_1 - \theta_2)$$

$$z^n = r^n \operatorname{cis}(n\theta) \quad (\text{de Moivre's theorem})$$

Calculus

$$\frac{d}{dx}(x^n) = nx^{n-1}$$

$$\int x^n dx = \frac{1}{n+1} x^{n+1} + c, n \neq -1$$

$$\frac{d}{dx}(e^{ax}) = ae^{ax}$$

$$\int e^{ax} dx = \frac{1}{a} e^{ax} + c$$

$$\frac{d}{dx}(\log_e(x)) = \frac{1}{x}$$

$$\int \frac{1}{x} dx = \log_e(x) + c, \text{ for } x > 0$$

$$\frac{d}{dx}(\sin(ax)) = a \cos(ax)$$

$$\int \sin(ax) dx = -\frac{1}{a} \cos(ax) + c$$

$$\frac{d}{dx}(\cos(ax)) = -a \sin(ax)$$

$$\int \cos(ax) dx = \frac{1}{a} \sin(ax) + c$$

$$\frac{d}{dx}(\tan(ax)) = a \sec^2(ax)$$

$$\int \sec^2(ax) dx = \frac{1}{a} \tan(ax) + c$$

$$\frac{d}{dx}(\operatorname{Sin}^{-1}(x)) = \frac{1}{\sqrt{1-x^2}}$$

$$\int \frac{1}{\sqrt{a^2-x^2}} dx = \operatorname{Sin}^{-1}\left(\frac{x}{a}\right) + c, a > 0$$

$$\frac{d}{dx}(\operatorname{Cos}^{-1}(x)) = \frac{-1}{\sqrt{1-x^2}}$$

$$\int \frac{-1}{\sqrt{a^2-x^2}} dx = \operatorname{Cos}^{-1}\left(\frac{x}{a}\right) + c, a > 0$$

$$\frac{d}{dx}(\operatorname{Tan}^{-1}(x)) = \frac{1}{1+x^2}$$

$$\int \frac{a}{a^2+x^2} dx = \operatorname{Tan}^{-1}\left(\frac{x}{a}\right) + c$$

product rule:
$$\frac{d}{dx}(uv) = u \frac{dv}{dx} + v \frac{du}{dx}$$

quotient rule:
$$\frac{d}{dx}\left(\frac{u}{v}\right) = \frac{v \frac{du}{dx} - u \frac{dv}{dx}}{v^2}$$

chain rule:
$$\frac{dy}{dx} = \frac{dy}{du} \frac{du}{dx}$$

Reproduced with permission of the Victorian Curriculum and Assessment Authority, Victoria, Australia.

These formula sheets have been copied from the 2003 Specialist Maths Exam 1. Teachers and students are reminded that changes to formula sheets are notified in the VCE Bulletins and on the VCAA website at www.vcaa.vic.edu.au

The VCAA publish an exam issue supplement to the VCAA Bulletin.

mid-point rule: $\int_a^b f(x)dx \approx (b-a)f\left(\frac{a+b}{2}\right)$

trapezoidal rule: $\int_a^b f(x)dx \approx \frac{1}{2}(b-a)(f(a) + f(b))$

Euler's method: If $\frac{dy}{dx} = f(x)$, $x_0 = a$ and $y_0 = b$,
then $x_{n+1} = x_n + h$ and $y_{n+1} = y_n + hf(x_n)$

acceleration: $a = \frac{d^2x}{dt^2} = \frac{dv}{dt} = v \frac{dv}{dx} = \frac{d}{dx} \left(\frac{1}{2} v^2 \right)$

constant (uniform) acceleration: $v = u + at$ $s = ut + \frac{1}{2} at^2$
 $v^2 = u^2 + 2as$ $s = \frac{1}{2}(u + v)t$

Vectors in two and three dimensions

$$\vec{r} = x\vec{i} + y\vec{j} + z\vec{k}$$

$$|\vec{r}| = \sqrt{x^2 + y^2 + z^2} = r$$

$$\vec{r}_1 \cdot \vec{r}_2 = r_1 r_2 \cos \theta = x_1 x_2 + y_1 y_2 + z_1 z_2$$

$$\dot{\vec{r}} = \frac{d\vec{r}}{dt} = \frac{dx}{dt}\vec{i} + \frac{dy}{dt}\vec{j} + \frac{dz}{dt}\vec{k}$$

Mechanics

momentum: $\vec{p} = m\vec{v}$

equation of motion: $\vec{R} = m\vec{a}$

friction: $F \leq \mu N$

Reproduced with permission of the Victorian Curriculum and Assessment Authority, Victoria, Australia.

These formula sheets have been copied from the 2003 Specialist Maths Exam 1. Teachers and students are reminded that changes to formula sheets are notified in the VCE Bulletins and on the VCAA website at www.vcaa.vic.edu.au

The VCAA publish an exam issue supplement to the VCAA Bulletin.

SPECIALIST MATHEMATICS

TRIAL EXAMINATION 1

MULTIPLE- CHOICE ANSWER SHEET

STUDENT NAME:.....

INSTRUCTIONS

Fill in the letter that corresponds to your choice. Example: A B C D E

The answer selected is B. Only one answer should be selected.

- | | | |
|--------------------------------------------------------------------------------------------------------------------------------------------|--------------------------------------------------------------------------------------------------------------------------------------------|--------------------------------------------------------------------------------------------------------------------------------------------|
| 1. <input type="checkbox"/> A <input type="checkbox"/> B <input type="checkbox"/> C <input type="checkbox"/> D <input type="checkbox"/> E | 11. <input type="checkbox"/> A <input type="checkbox"/> B <input type="checkbox"/> C <input type="checkbox"/> D <input type="checkbox"/> E | 21. <input type="checkbox"/> A <input type="checkbox"/> B <input type="checkbox"/> C <input type="checkbox"/> D <input type="checkbox"/> E |
| 2. <input type="checkbox"/> A <input type="checkbox"/> B <input type="checkbox"/> C <input type="checkbox"/> D <input type="checkbox"/> E | 12. <input type="checkbox"/> A <input type="checkbox"/> B <input type="checkbox"/> C <input type="checkbox"/> D <input type="checkbox"/> E | 22. <input type="checkbox"/> A <input type="checkbox"/> B <input type="checkbox"/> C <input type="checkbox"/> D <input type="checkbox"/> E |
| 3. <input type="checkbox"/> A <input type="checkbox"/> B <input type="checkbox"/> C <input type="checkbox"/> D <input type="checkbox"/> E | 13. <input type="checkbox"/> A <input type="checkbox"/> B <input type="checkbox"/> C <input type="checkbox"/> D <input type="checkbox"/> E | 23. <input type="checkbox"/> A <input type="checkbox"/> B <input type="checkbox"/> C <input type="checkbox"/> D <input type="checkbox"/> E |
| 4. <input type="checkbox"/> A <input type="checkbox"/> B <input type="checkbox"/> C <input type="checkbox"/> D <input type="checkbox"/> E | 14. <input type="checkbox"/> A <input type="checkbox"/> B <input type="checkbox"/> C <input type="checkbox"/> D <input type="checkbox"/> E | 24. <input type="checkbox"/> A <input type="checkbox"/> B <input type="checkbox"/> C <input type="checkbox"/> D <input type="checkbox"/> E |
| 5. <input type="checkbox"/> A <input type="checkbox"/> B <input type="checkbox"/> C <input type="checkbox"/> D <input type="checkbox"/> E | 15. <input type="checkbox"/> A <input type="checkbox"/> B <input type="checkbox"/> C <input type="checkbox"/> D <input type="checkbox"/> E | 25. <input type="checkbox"/> A <input type="checkbox"/> B <input type="checkbox"/> C <input type="checkbox"/> D <input type="checkbox"/> E |
| 6. <input type="checkbox"/> A <input type="checkbox"/> B <input type="checkbox"/> C <input type="checkbox"/> D <input type="checkbox"/> E | 16. <input type="checkbox"/> A <input type="checkbox"/> B <input type="checkbox"/> C <input type="checkbox"/> D <input type="checkbox"/> E | 26. <input type="checkbox"/> A <input type="checkbox"/> B <input type="checkbox"/> C <input type="checkbox"/> D <input type="checkbox"/> E |
| 7. <input type="checkbox"/> A <input type="checkbox"/> B <input type="checkbox"/> C <input type="checkbox"/> D <input type="checkbox"/> E | 17. <input type="checkbox"/> A <input type="checkbox"/> B <input type="checkbox"/> C <input type="checkbox"/> D <input type="checkbox"/> E | 27. <input type="checkbox"/> A <input type="checkbox"/> B <input type="checkbox"/> C <input type="checkbox"/> D <input type="checkbox"/> E |
| 8. <input type="checkbox"/> A <input type="checkbox"/> B <input type="checkbox"/> C <input type="checkbox"/> D <input type="checkbox"/> E | 18. <input type="checkbox"/> A <input type="checkbox"/> B <input type="checkbox"/> C <input type="checkbox"/> D <input type="checkbox"/> E | 28. <input type="checkbox"/> A <input type="checkbox"/> B <input type="checkbox"/> C <input type="checkbox"/> D <input type="checkbox"/> E |
| 9. <input type="checkbox"/> A <input type="checkbox"/> B <input type="checkbox"/> C <input type="checkbox"/> D <input type="checkbox"/> E | 19. <input type="checkbox"/> A <input type="checkbox"/> B <input type="checkbox"/> C <input type="checkbox"/> D <input type="checkbox"/> E | 29. <input type="checkbox"/> A <input type="checkbox"/> B <input type="checkbox"/> C <input type="checkbox"/> D <input type="checkbox"/> E |
| 10. <input type="checkbox"/> A <input type="checkbox"/> B <input type="checkbox"/> C <input type="checkbox"/> D <input type="checkbox"/> E | 20. <input type="checkbox"/> A <input type="checkbox"/> B <input type="checkbox"/> C <input type="checkbox"/> D <input type="checkbox"/> E | 30. <input type="checkbox"/> A <input type="checkbox"/> B <input type="checkbox"/> C <input type="checkbox"/> D <input type="checkbox"/> E |