

# 2024 - 2027

# VCE

# Physics

# Units 3 and 4

# Examination



**Kilbaha Education**

Quality educational content

Kilbaha Education (Est. 1978) (ABN 47 065 111 373)  
PO Box 3229  
Cotham Vic 3101  
Australia

PayID: 47065111373  
Email: [kilbaha@gmail.com](mailto:kilbaha@gmail.com)  
Tel: (03) 9018 5376  
Web: <https://kilbaha.com.au>

*This educational resource from Kilbaha Education is digital and is supplied to the purchasing school in both WORD and PDF formats with a school site licence to reproduce for students in both print and electronic formats.*

# VICTORIAN CERTIFICATE OF EDUCATION

## Years 2024 - 2027

NAME .....

Teacher .....

# PHYSICS Units 3 and 4

## Trial Written Examination

Reading time: 15 minutes

Writing time: 2 hour 30 minutes

### QUESTION AND ANSWER BOOK

#### Structure of book

<i>Section</i>	<i>Number of questions</i>	<i>Number of questions to be answered</i>	<i>Number of marks</i>
A	20	20	20
B	15	15	100
Total	35	35	120

#### Approved Materials

- One scientific calculator
- Pre-written notes (one folded A3 sheet or two A4 sheets bound together by tape)
- Pens, pencils, highlighters, erasers, sharpeners and rulers

Students are NOT permitted to bring into the examination room: blank sheets of paper and/or white out liquid/tape

#### Materials supplied

- Question and answer book of 30 pages
- A formula sheet in an additional 4 pages

#### Instructions

- Write your **Name** in the space provided above on this page.
- Write your teacher's name in the space provided.
- Unless otherwise indicated, the diagrams in this book are **not** drawn to scale.
- All written responses must be in English.

**Students are NOT permitted to bring mobile phones and/or any other unauthorised electronic devices into the examination room.**

**SECTION A – Multiple-choice questions**

**20 marks**

**Instructions for Section A**

Answer all questions in pencil on the answer sheet provided for multiple-choice questions. Choose the response that is correct or that best answers the question.

A correct answer scores 1; an incorrect answer scores 0.

Marks will not be deducted for incorrect answers.

No marks will be given if more than one answer is completed for any question.

Unless otherwise indicated, the diagrams in this book are not drawn to scale.

Take the value of  $g$  to be  $9.81 \text{ m s}^{-2}$ .

**Question 1 (1 mark)**

The horizontal and vertical components of the velocity of a projectile are  $v_H$  and  $v_V$  respectively. Which pair of graphs best represents the horizontal and vertical components of the velocity of the projectile?

**A.**

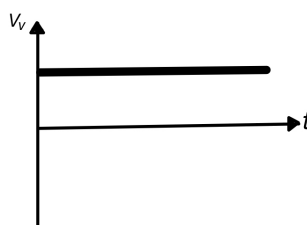
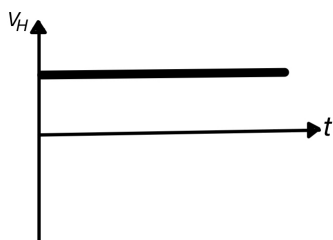

**B.**

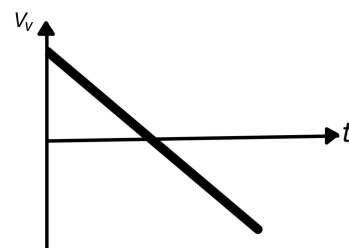
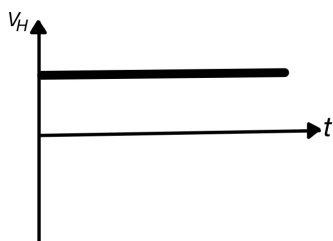

**C.**

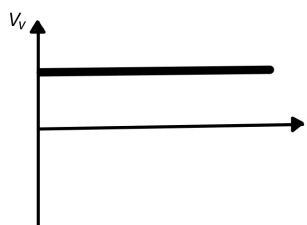
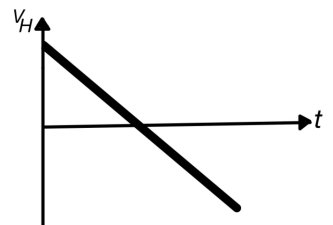

**D.**

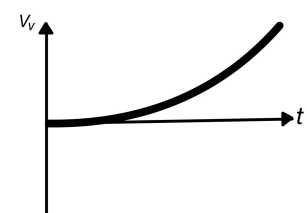
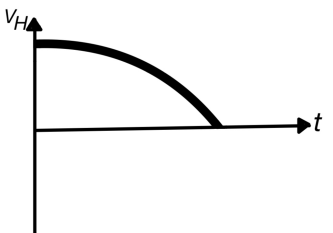

**Use the information given below to answer Questions 2 & 3**

An electron enters a region of uniform magnetic field at speed  $v$  as shown below. The electron is initially travelling perpendicular to the magnetic field. The electron turns down the page into a circular arc with radius  $r$ .

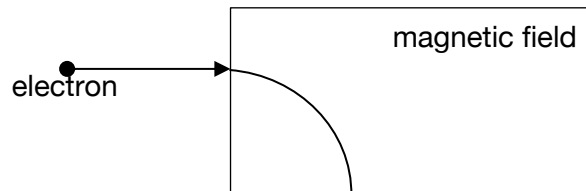

**Question 2 (1 mark)**

Which one of the following best describes the direction of the magnetic field?

- A. to the left
- B. to the right
- C. into the page
- D. out of the page

**Question 3 (1 mark)**

The speed of the electron is varied. Which of the following graph best represents the variation of the speed  $v$  with the radius  $r$ .

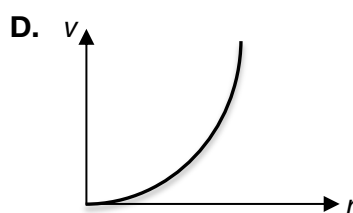
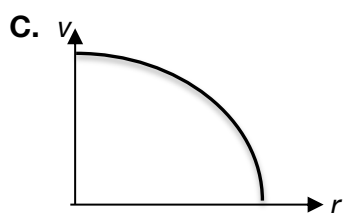
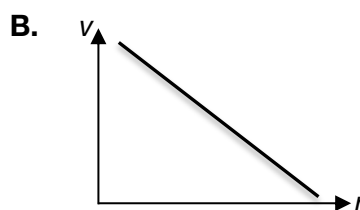
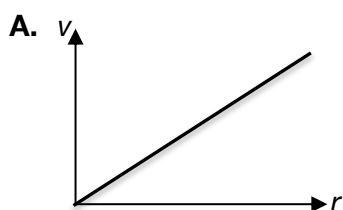

**Question 4 (1 mark)**

The diagram given below shows two positive point charges  $3 \times 10^{-6} \text{ C}$  and  $4 \times 10^{-6} \text{ C}$  separated by a distance of  $3 \times 10^{-3} \text{ m}$ .

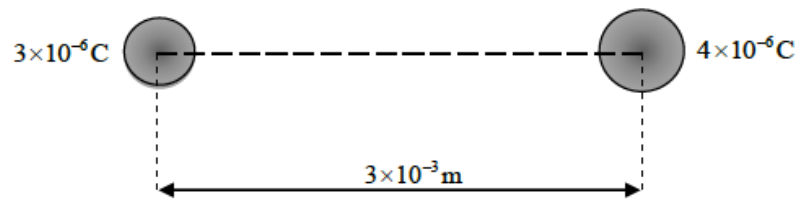

What is the magnitude of the force between the two charges?

- A. 36.0 N
- B.  $1.20 \times 10^4 \text{ N}$
- C.  $8.89 \times 10^{-17} \text{ N}$
- D.  $2.67 \times 10^{-19} \text{ N}$

**Question 5 (1 mark)**

The diagram given below shows the magnetic field surrounding two current carrying conductors P and Q. The wires are parallel to each other and at right angles to the plane of the page.

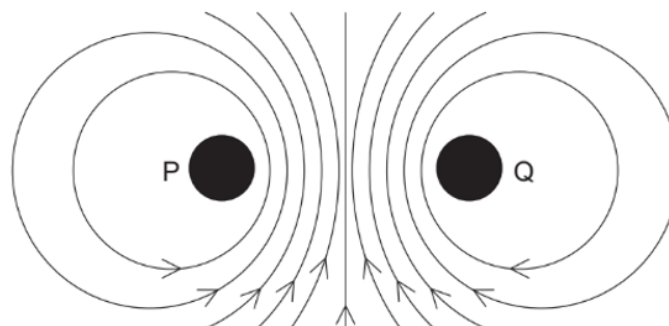

Which of the following best describe the direction of the current flow in the conductors P and Q?

- A. P – into the page      Q – into the page
- B. P – into the page      Q – out of the page
- C. P – out of the page      Q – out of the page
- D. P – out of the page      Q – into the page

**Question 6 (1 mark)**

An alternating current (AC) generator produces a peak emf  $E$  with a period of  $T$  seconds. What are the peak emf and period when the frequency of the rotation is halved?

	Peak emf	Period
A.	$2E$	$2T$
B.	$2E$	$\frac{T}{2}$
C.	$\frac{E}{2}$	$2T$
D.	$E$	$\frac{T}{2}$

**Question 7 (1 mark)**

Monochromatic light of wavelength  $x$  nanometres strikes a double slit and produces bright and dark fringes on a screen as shown below. Light from slit  $S_1$  travels along path  $P_1$  and light from slit  $S_2$  travels along  $P_2$  to produce the dark fringe shown.

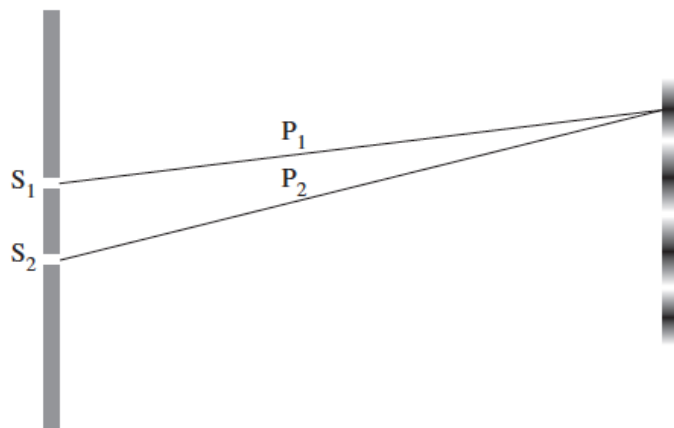

What is the difference in length between  $P_1$  and  $P_2$ ?

- A.  $\frac{x}{2}$
- B.  $x$
- C.  $\frac{3x}{2}$
- D.  $2x$

**Question 8 (1 mark)**

A compressed spring is used to launch an object along a horizontal frictionless surface. When the spring is compressed through a distance  $x$  and released, the object leaves the spring at speed  $v$  as shown below.

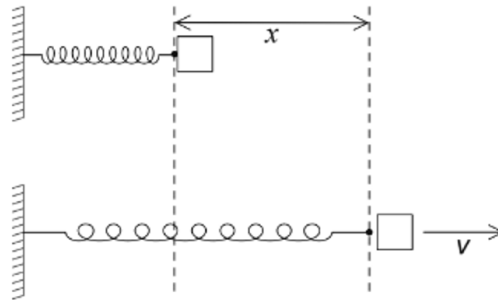

What is the distance through which the spring must be compressed for the object to leave the spring at speed  $2v$ ?

- A.  $\frac{x}{4}$
- B.  $\frac{x}{2}$
- C.  $2x$
- D.  $4x$

**Question 9 (1 mark)**

A satellite is orbiting a planet at a constant speed. Which of the following statements is correct?

- A. The satellite is not accelerating.
- B. The orbit of the satellite has a fixed radius.
- C. Fuel must be used to supply a constant thrust to the satellite.
- D. The centripetal force on the satellite is balanced by the gravitational force.

**Question 10 (1 mark)**

A student throws a ball that follows a parabolic trajectory. What change to the initial velocity would make the ball's time of flight shorter?

- A. Increasing only the vertical component.
- B. Decreasing only the vertical component.
- C. Increasing only the horizontal component.
- D. Decreasing only the horizontal component.

**Question 11 (1 mark)**

A proton and an electron travel at the same speed.

Which statement correctly explains the difference between their de Broglie wavelengths?

- A. The electron has a longer wavelength because its mass is smaller.
- B. The electron has a shorter wavelength because its mass is smaller.
- C. The proton has a shorter wavelength because its mass is greater.
- D. The proton has a longer wavelength because its mass is greater.

**Question 12 (1 mark)**

Why is high voltage used to transmit electrical energy from power stations to users?

- A. It helps to protect the system from lightning strikes.
- B. It allows the supporting structures to have smaller insulators.
- C. It minimises the effects of the electrical resistance of the wires.
- D. It ensures that, even with voltage losses, 240 V will still reach the user.

**Question 13 (1 mark)**

The graph shows the variation with time of a magnetic flux passing through a loop of wire.

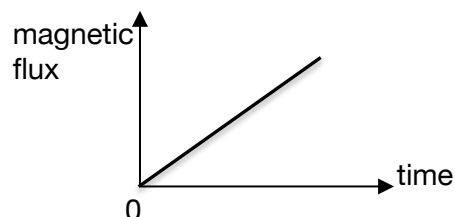

What is the magnitude of the emf induced in the coil?

- A. The area between the graph and the time axis.
- B. The gradient of the graph.
- C. The inverse of the gradient of the graph.
- D. Cannot be determined from a flux-time graph.

**Question 14 (1 mark)**

Some metals emit electrons when illuminated with light of high frequency. What happens when the brightness of the light is increased without any change in the light frequency?

- A. The same number of electrons are emitted per second with greater maximum velocity.
- B. The same number of electrons are emitted per second with no change in maximum velocity.
- C. More electrons are emitted per second with no change in maximum velocity.
- D. More electrons are emitted per second with greater maximum velocity.



**Use the information given below to answer Questions 15, 16 & 17**

A film crew is filming a stunt scene for a movie. They release a car from rest downhill from point A as shown below. When the car reaches the cliff at B it is projected horizontally and travels a horizontal distance,  $x$  metres, from the cliff edge. It enters the water at point C. Take the acceleration due to gravity as  $g \text{ m s}^{-2}$  downwards and ignore air resistance.

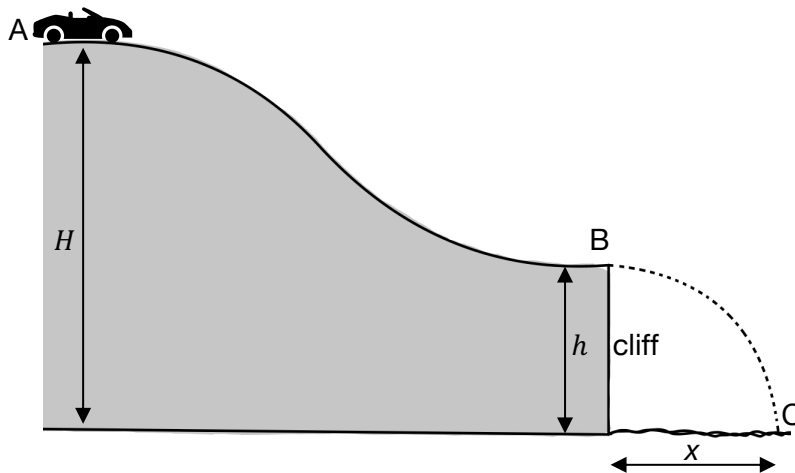

**Question 15 (1 mark)**

Which of the following expressions gives the speed of the car at point B?

- A.  $\sqrt{2gh}$
- B.  $\sqrt{2gH}$
- C.  $\sqrt{2g(h + H)}$
- D.  $\sqrt{2g(H - h)}$

**Question 16 (1 mark)**

Which of the statements is correct for the horizontal component of the velocity of the car at point C, just before hitting the water?

- A. The horizontal component of the velocity of the car at C is less than the speed at B.
- B. The horizontal component of the velocity of the car at C is equal to the speed at B.
- C. The horizontal component of the velocity of the car at C is greater than the speed at B.
- D. The value of the horizontal component of the velocity at C depends on the height of the cliff.

**Question 17 (1 mark)**

Which of the following expressions gives the speed of the car at point C?

- A.  $\sqrt{2gh}$
- B.  $\sqrt{2gH}$
- C.  $\sqrt{2g(h + H)}$
- D.  $\sqrt{2g(H - h)}$

**Question 18 (1 mark)**

The ability to distinguish between two closely spaced objects in an image is primarily determined by the

- A. Brightness of the image
- B. Size of the aperture
- C. Resolution of the imaging system
- D. Distance from the object to the lens

**Question 19 (1 mark)**

What evidence resulting from investigations into the photoelectric effect is consistent with the model of light subsequently proposed by Einstein?

- A. Photoelectrons were only ejected from a metal if the light was less than a specific wavelength.
- B. Increasing the intensity of light on a metal increased the maximum kinetic energy of the photoelectrons.
- C. If photons had sufficient energy to eject photoelectrons from a metal, the maximum kinetic energy was independent of the type of metal used.
- D. The probability of photoelectrons being emitted from a metal was proportional to the duration of exposure to light for any given wavelength used.

**Question 20 (1 mark)**

The emission of electrons from the surface of a metal when light falls on its surface is called photoelectric effect. Which of the following statements gives the best explanation for this effect?

- A. Because the light cannot penetrate far into the metal, the light energy heats up the surface and the electrons evaporate.
- B. As the light energy is absorbed, the metal expands forcing electrons off the surface.
- C. Photons excite the metal atoms near the surface to higher energy states, the atoms then drop back to the ground state by emitting electrons.
- D. When the photons collide with an electron near the surface of the metal, its energy is acquired by the electron which may then escape from the metal.

**END OF SECTION A**

**SECTION B – Short Answer questions**

**100 marks**

**Instructions for Section B**

Answer all questions in the spaces provided.

Where an answer box is provided, write your final answer in the box.

If an answer box has a unit printed in it, give your answer in that unit.

In questions where more than one mark is available, appropriate working must be shown.

Unless otherwise indicated, the diagrams in this book are not drawn to scale.

Take the value of  $g$  to be  $9.8 \text{ m s}^{-2}$ .

**Question 1 (3 marks)**

A copper rod, PQ moves horizontally to the right at a uniform speed of  $4 \text{ m s}^{-1}$  along two conducting rails  $3 \text{ m}$  apart that are connected to a  $12 \Omega$  resistor. The set-up is in a magnetic field,  $B$ , of  $0.6 \text{ T}$  directed into the page as shown in Figure 1.

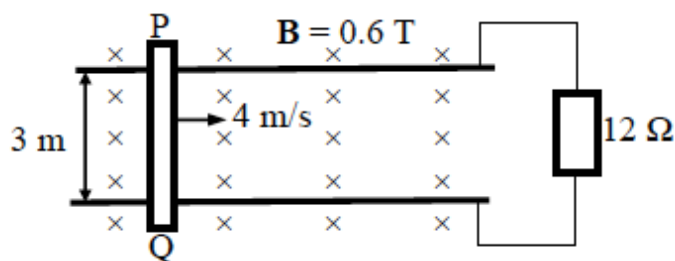

**Figure 1**

Calculate the current induced in the  $12 \Omega$  resistor.

**3 marks**

---

---

---

---

---

A
---

**Question 2 (5 marks)**

Two laboratory trolleys travelling in the same direction collide. At impact they stick together.

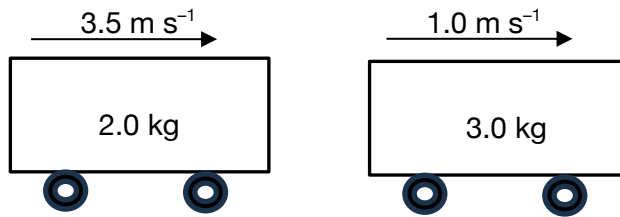

- a. Show that the speed of their combined masses just after impact is 2 m s<sup>-1</sup>?

2 marks

---

---

---

---

---

- b. Is the collision elastic or inelastic? Justify your answer with calculations.

3 marks

---

---

---

---

---

**Question 3 (6 marks)**

The diagram below shows a circular loop with a radius of 5 cm in a magnetic field. The whole loop is inside the magnetic field and is perpendicular to the magnetic field. The loop experiences a uniform magnetic field of 0.15 T.

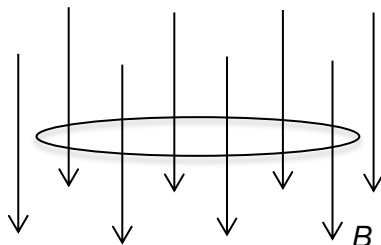

The magnitude of the magnetic field is then reduced to zero at a constant rate over a period of 0.5 s.

- a.** Calculate the magnitude of the emf induced in the coil. 3 marks

---

---

---

---

---

---

V
---

- b.** Determine the direction of the induced current in the loop as viewed from above (anticlockwise or clockwise). Justify your answer. 3 marks

--

---

---

---

---

---

---

**Question 4 (5 marks)**

A car travelling at  $27 \text{ m s}^{-1}$  crashes and activates its airbag. The  $90 \text{ kg}$  driver comes to a stop in  $40 \text{ milliseconds}$ .

- a. Calculate the magnitude of the impulse experienced by the driver. 2 marks

---

---

---

---

---

---

---

N s

- b. Calculate the magnitude of the average force experienced by the driver. 2 marks

---

---

---

---

---

---

---

N

- c. Explain what happens to the kinetic energy of the car as the car comes to a stop after the crash. 1 mark

---

---

---

**Question 5 (10 marks)**

A spacecraft is placed into an orbit around an unnamed planet. The information regarding the planet and the spacecraft are given in the table below.

**Data**

Mass of the planet	$5.68 \times 10^{26} \text{ kg}$
Gravitational field strength near the surface of the planet	$10.9 \text{ N kg}^{-1}$
Mass of spacecraft	2000 kg
Period of the spacecraft	9 hours 45 minutes

a. Calculate the radius of the planet.

2 marks

---

---

---

---

---

---

---

---

m

b. Calculate the radius of the orbit of the spacecraft.

3 marks

---

---

---

---

---

---

---

---

m

**Question 5 (continued)**

c. Calculate the speed of the spacecraft.

2 marks

---

---

---

---

---

---

---

---

$\text{m s}^{-1}$
-------------------

d. Scientists wish to place another spacecraft, of mass 1000 kg, in an orbit of the same radius as the previous one. Two students, Ricky and Ponting, are discussing the situation and have different opinions:

Ricky says as the spacecraft is lighter, it will have to move at a greater speed to achieve the same orbit.

Ponting says the spacecraft would need to move at a lower speed as it is lighter.

Evaluate these two opinions.

3 marks

---

---

---

---

---

---

---

---

---

---

---

---



**Question 6 (5 marks)**

A single rectangular flat loop of wire, 5 cm x 4 cm, enters a uniform magnetic field at a constant speed of  $2.5 \text{ cm s}^{-1}$  as shown below. The direction of the magnetic field is into the page.

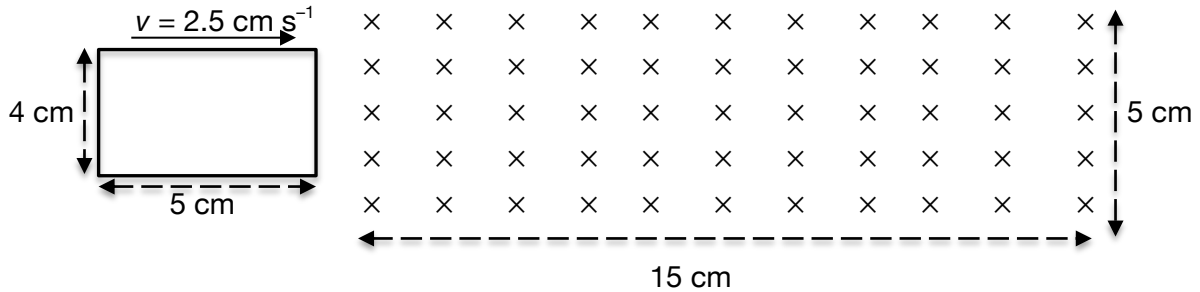

The right edge of the loop enters the magnetic field at time  $t = 0$ . The peak EMF induced in the loop is 10 mV.

- a. Sketch the graph showing the induced EMF as a function of time in the grid given below, until the left edge of loop leaves the magnetic field. Clearly label the  $t$  axis. 3 marks

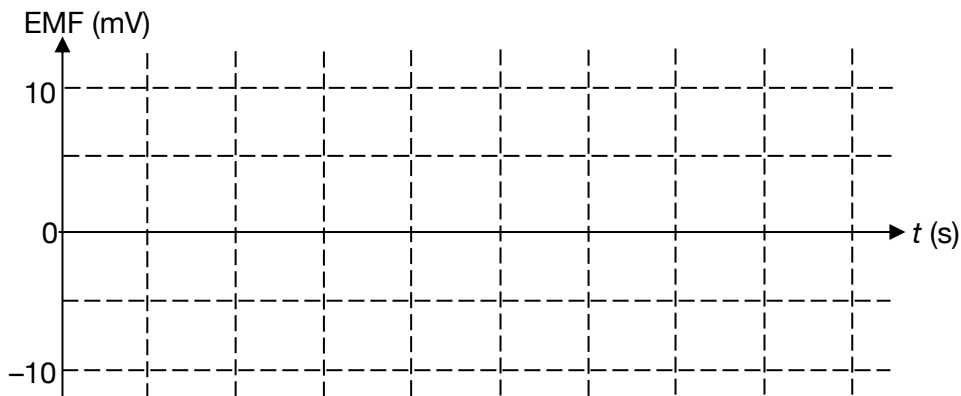

- b. Calculate the strength of the magnetic field. 2 marks

---



---



---



---



---



---

T

**Question 7 (5 marks)**

The James Webb Space Telescope (JWST) has a mass of 6500 kg and orbits the Sun at a distance of approximately  $1.61 \times 10^{11}$  m.

- a. Calculate the magnitude of the gravitational force the Sun exerts on the telescope.  
The Sun has a mass of  $1.99 \times 10^{30}$  kg. 2 marks

---

---

---

---

---

---

---

---

N
---

- b. The telescope is sensitive to wavelengths from  $6.0 \times 10^{-7}$  m to  $2.8 \times 10^{-5}$  m. What is the minimum photon energy that it can detect? 3 marks

---

---

---

---

---

---

---

---

J
---

**Question 8 (9 marks)**

The diagram below shows two parallel plates connected to a 12 V battery. The plates are separated by a distance of 2.5 cm.

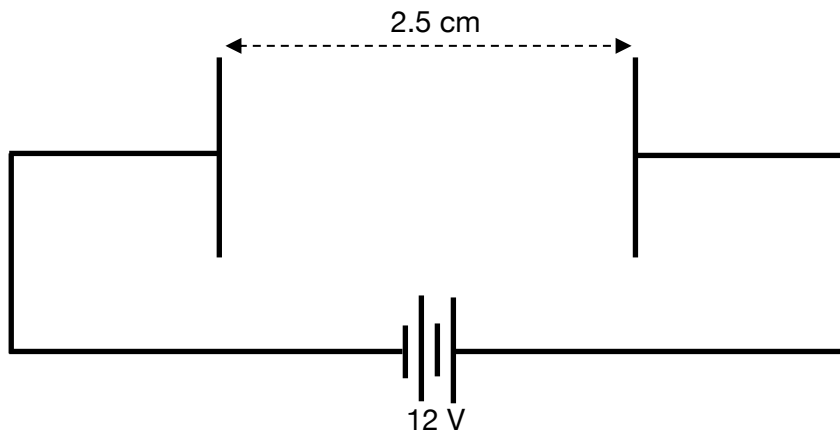

- a. On the diagram above sketch the electric field between the plates, showing the direction of the electric field. Use at least 4 field lines. 2 marks
  
- b. Calculate the magnitude of the electric field between the plates. 2 marks

---

---

---

---

---

N C<sup>-1</sup>

An electron is accelerated from rest from one plate to another.

- c. Calculate the magnitude of the change in kinetic energy of the electron as it accelerates between the plates. 2 marks

---

---

---

---

---

J

**Question 8 (continued)**

- d. Ravi says that the force on the electron increases as it accelerates between the plates, but her friend Nami argues that the force on the electron is constant. Who is correct, Ravi or Nami? Explain your answer. 3 marks

---

---

---

---

---

---

---

---

---

---

**Question 9 (6 marks)**

Marie points a red laser with a frequency of  $4.55 \times 10^{14}$  Hz at a double slit and observes a pattern of light and dark fringes on a screen as shown below. Point C is the brightest fringe and D is a dark fringe.

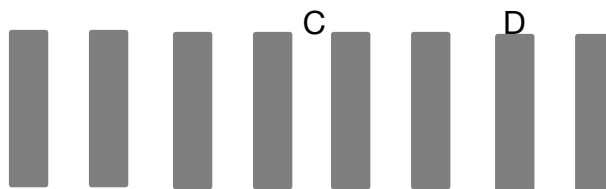

- a. Calculate the wavelength of the red laser. 1 mark

---

---

nm

- b. Calculate the path difference from the slits to point D. 2 marks

---

---

nm

- c. Marie exchanges the red laser with one of frequency  $4.95 \times 10^{14}$  Hz. Describe the effect that this change will have on the pattern of bright and dark fringes. 1 mark.

---

---

- d. Explain how the pattern of bright and dark fringes formed on the screen provides evidence for the wave nature of light. 2 marks

---

---

---

---

---

---

**Question 10 (4 marks)**

A string is fixed at both ends and plucked to form a standing wave as shown below. The distance between points A and B is 2.2 m.

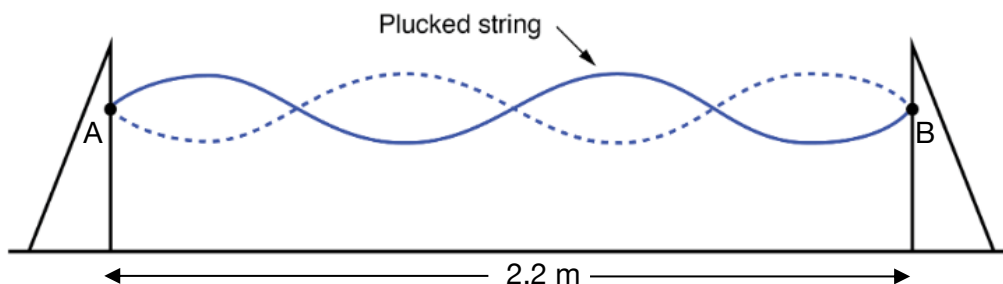

- a. Calculate the speed of the wave generated on the string if the period of the vibration of the standing wave is 1.8 s. 2 marks

---

---

---

---

---

---

---

---

m s<sup>-1</sup>

- b. The tension in the wire is now increased so that the speed of the travelling waves is 6.0 m s<sup>-1</sup>. What will be the frequency of the wave if the same standing wave as shown above is formed. 2 marks

---

---

---

---

---

---

---

---

Hz

**Question 11 (11 marks)**

The diagram below shows a marble of mass 200 g resting against a spring on an inclined plane with an angle of incline of  $30^\circ$ . The spring has a spring constant of  $180 \text{ N m}^{-1}$ .

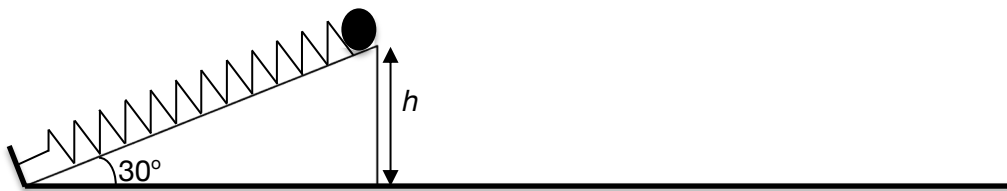

A group of students compress the spring a distance of 10 cm and the marble is released as a projectile as shown and lands on the ground. Ignore air resistance.

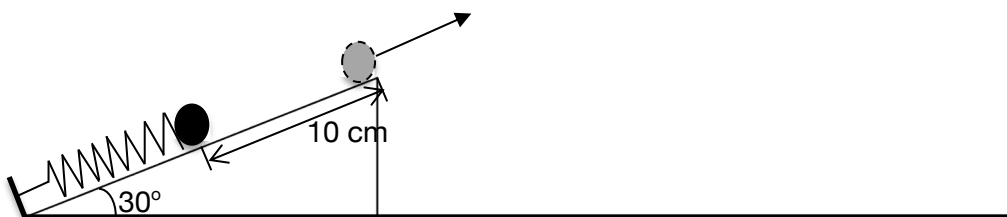

- a. Show that the speed with which the marble leaves the inclined plane is  $3 \text{ m s}^{-1}$ . 2 marks

---

---

---

---

---

- b. Calculate the time taken by the ball to reach the maximum height. 2 marks

---

---

---

---

---

s
---

**Question 11 (continued)**

c. The marble was in the air for 0.45 s. Calculate the height,  $h$ , of the inclined plane.

2 marks

---

---

---

---

---

m
---

d. How far from the base of the inclined plane does the marble land?

2 marks

---

---

---

---

m
---

e. The same experiment is repeated with a marble of mass 400 g. State whether each of the quantities listed in the table below increase, decreases or remains the same.

3 marks

Quantity	Increases/decreases/remains the same
The speed with which the marble leaves the inclined plane.	
The time taken to reach the maximum height.	
The horizontal distance from the base of the inclined plane to where the marble lands.	



**Question 12 (7 marks)**

30 keV X-ray photons were shone through a thin layer of aluminium and produced the pattern on the left. When electrons were shot at the same aluminium foil, the pattern on the right was formed.

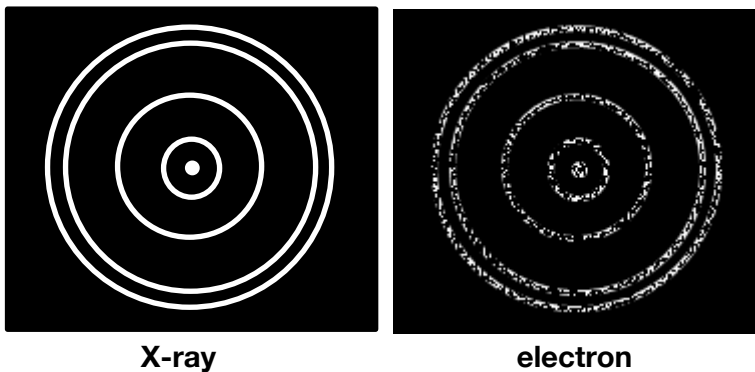

- a. Calculate the speed of the electrons passing through the aluminium foil.

2 marks

---

---

---

---

---

---

---

$\text{m s}^{-1}$
-------------------

- b. Explain what happens to the diffraction pattern if the electron's momentum is increased.

2 marks

---

---

---

---

---

---

---

**Question 12 (continued)**

c. Two physics students discuss the following about the diffraction patterns:

Madi argues that the patterns look the same as the X-rays and the electrons have the same speed.

Mada disagrees and says that the patterns are similar due to the X-rays and electrons having similar energy.

Evaluate the two statements, stating who, if either, is correct. 3 marks

---

---

---

---

---

---

---

---

---

---

---

---

---

---

---

---

**Question 13 (5 marks)**

The diagram below shows the energy levels of an atom.

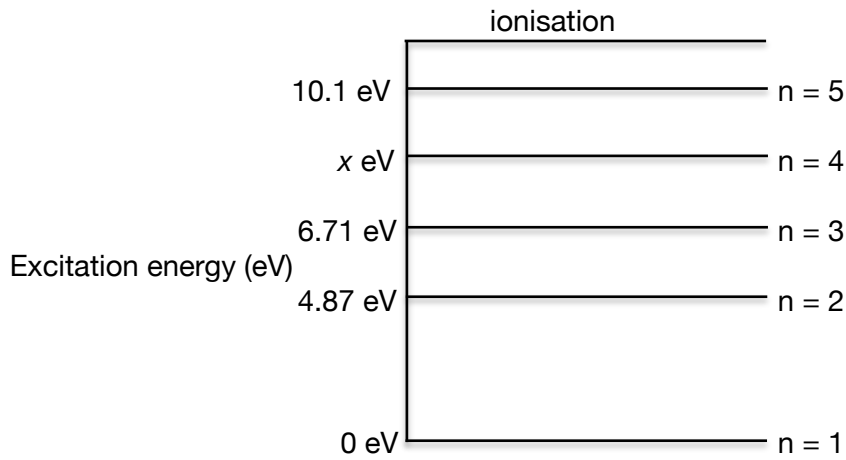

- a. A sample of the atom is excited into the energy level  $n = 2$ . Explain why a photon of energy 1.84 eV can be absorbed but not emitted by the atom. 2 marks

---

---

---

---

---

---

---

---

- b. Other photon energies that can be absorbed from the transition level  $n = 2$  include 6.24 eV, 5.23 eV and 3.37 eV. Use this information to find the value of  $x$  in the energy level diagram given above. 2 marks

---

---

---

eV

- c. Another sample of the atoms is excited into the energy level  $n = 5$ . The atom then transitions to the ground level and a line spectrum is observed. What is the total number of lines in the spectrum? Assume all transitions occur. 1 mark

---

---

**Question 14 (7 marks)**

The diagram given below shows the dimensions of a spaceship when it is stationary on Earth.

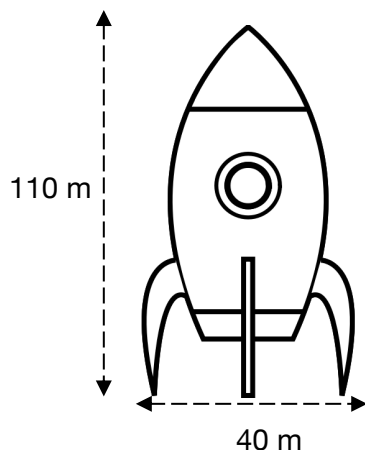

The same spaceship is seen by an astronaut in space travelling at a speed of  $0.75c$  as shown below and notices that one of measurements is different to that taken on Earth.

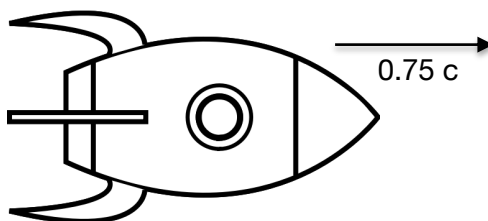

- a. State which measurement will be different as observed by the astronaut and explain why in terms of special relativity. 3 marks

---

---

---

---

---

---

- b. Calculate this new measurement as observed by the astronaut. 2 marks

---

---

---

---

	m
--	---

**Question 14 (continued)**

- c. The relativistic kinetic energy of the spaceship is  $1.61 \times 10^{20}$  J. Calculate the rest mass of the spaceship. 2 marks

---

---

---

---

---

---

---

---

kg
----

**Question 15 (12 marks)**

Jack and Jill are conducting a photoelectric effect experiment using the circuit shown below.

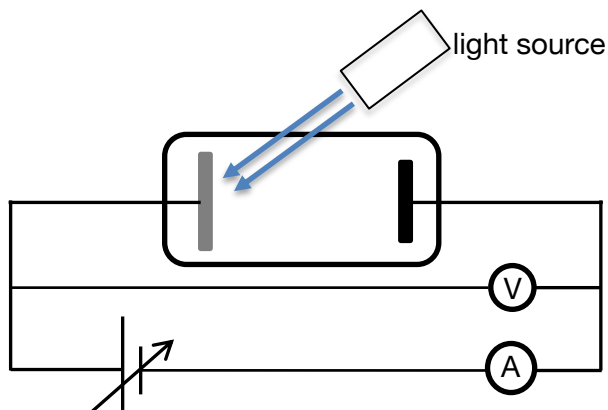

They use a sodium cathode and take the following measurements.

Frequency ( $\times 10^{14}$ Hz)	Stopping Voltage ( $\pm 0.02$ V)
6.0	1.02
7.0	1.40
8.0	1.86
9.0	2.25

- a. Use the grid given below to graph the data collected by Jack and Jill. Include appropriate uncertainty bars and a line of best fit. 5 marks

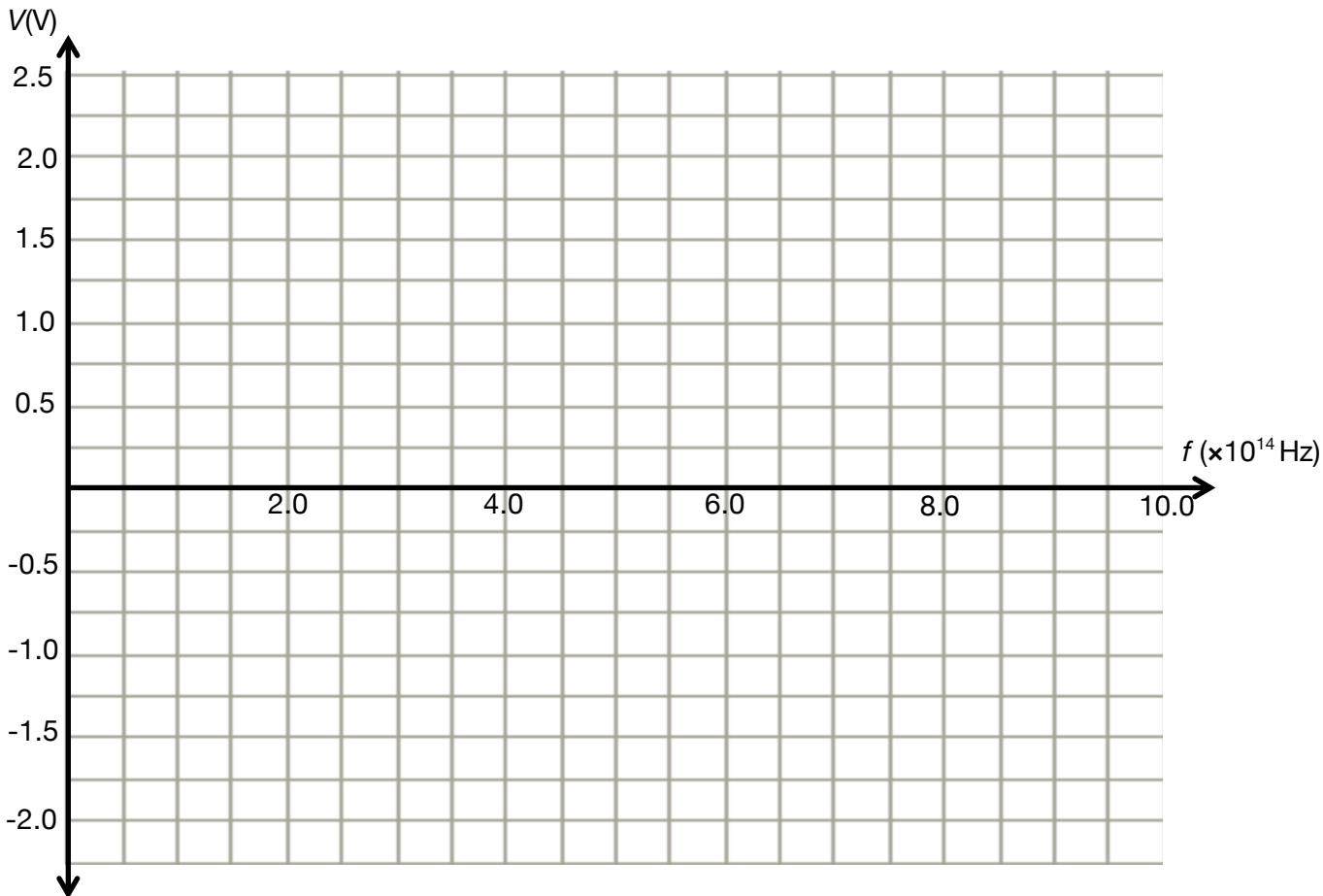

**Question 15 (continued)**

- b. Using the graph calculate the Plank's constant. Include the unit with your answer.  
3 marks

---

---

---

---

---

---

---

---

---

---

Magnitude:	Unit:
------------	-------

- c. Calculate the work function of the Sodium Cathode used by Jack and Jill. 2 marks

---

---

---

---

---

eV
----

- d. Explain the physical meaning of the term work function in reference to Jack and Jill's experiment.  
2 marks

---

---

---

---

---

---

---

---

**End of questions for the 2024 - 2027 Kilbaha Units 3 and 4 Physics Examination**

## Formula List

### Motion in two dimensions

velocity; acceleration	$v = \frac{\Delta s}{\Delta t}; \quad a = \frac{\Delta v}{\Delta t}$
equations for constant acceleration	$v = u + at$ $s = ut + \frac{1}{2}at^2$ $v^2 = u^2 + 2as$ $s = \frac{1}{2}(v + u)t$
Newton's second law	$\Sigma F = ma$
uniform circular motion	$F_{net} = \frac{mv^2}{r} \quad v = \frac{2\pi r}{T}$
Hooke's law	$F = -k\Delta x$
elastic potential energy	$E_s = \frac{1}{2}k(\Delta x)^2$
gravitational potential energy near the surface of Earth	$E_g = mg\Delta h$
kinetic energy	$E_k = \frac{1}{2}mv^2$
impulse	$F\Delta t = m\Delta v$
momentum	$p = mv$

### Fields and application of field concepts

electric field between charged plates	$E = \frac{V}{d}$
energy transformations of charges in an electric field	$\frac{1}{2}mv^2 = qV$
field of a point charge	$E = \frac{kQ}{r^2}$
force on an electric charge	$F = qE$
Coulomb's law	$F = \frac{kq_1q_2}{r^2}$



magnetic force on a moving charge	$F = qvB$
magnetic force on a current carrying conductor	$F = nIlB$
radius of a charged particle in a magnetic field	$r = \frac{mv}{qB}$
Newton's law of universal gravitation	$F = \frac{Gm_1m_2}{r^2}$
gravitational field	$g = \frac{GM}{r^2}$

### Generation and transmission of electricity

voltage; power	$V = IR; \quad P = VI = I^2R$
resistors in series	$R_T = R_1 + R_2 + \dots + R_n$
resistors in parallel	$\frac{1}{R_T} = \frac{1}{R_1} + \frac{1}{R_2} + \dots + \frac{1}{R_n}$
ideal transformer action	$\frac{V_1}{V_2} = \frac{N_1}{N_2} = \frac{I_2}{I_1}$
AC voltage and current	$V_{RMS} = \frac{1}{\sqrt{2}}V_{peak}; \quad I_{RMS} = \frac{1}{\sqrt{2}}I_{peak}$
electromagnetic induction: EMF	$\varepsilon = -N \frac{\Delta\Phi_B}{\Delta t}$
electromagnetic induction: flux	$\Phi_B = B_{\perp}A$
transmission losses: voltage	$V_{drop} = I_{line}R_{line}$
transmission losses: power	$P_{loss} = I_{line}^2R_{line}$

## Waves

wave equation	$v = f\lambda$
constructive interference	path difference = $n\lambda$
destructive interference	path difference = $(n + \frac{1}{2})\lambda$
interference pattern spacing	$\Delta x = \frac{\lambda L}{d}$ when $L \gg d$

## The nature of light and matter

photoelectric effect	$E_{k \max} = hf - \phi$
photon energy	$E = hf = \frac{hc}{\lambda}$
photon momentum	$p = \frac{h}{\lambda}$
de Broglie wavelength	$\lambda = \frac{h}{p}$

## Einstein's special theory of relativity

Lorentz factor	$\gamma = \frac{1}{\sqrt{1 - \frac{v^2}{c^2}}}$
time dilation	$t = \gamma t_0$
length contraction	$L = \frac{L_0}{\gamma}$
relativistic rest energy	$E_0 = mc^2$
relativistic total energy	$E_{\text{total}} = E_k + E_0 = \gamma mc^2$
relativistic kinetic energy	$E_k = (\gamma - 1)mc^2$

**Data**

acceleration due to gravity at Earth's surface	$g = 9.81 \text{ m s}^{-2}$
mass of the electron	$m_e = 9.11 \times 10^{-31} \text{ kg}$
magnitude of the charge of an electron	$e = 1.60 \times 10^{-19} \text{ C}$
Speed of light in a vacuum	$c = 3.00 \times 10^8 \text{ m s}^{-1}$
universal gravitational constant	$G = 6.67 \times 10^{-11} \text{ N m}^2 \text{ kg}^{-2}$
mass of Earth	$M_E = 5.97 \times 10^{24} \text{ kg}$
radius of Earth	$R_E = 6.37 \times 10^6 \text{ m}$
Coulomb constant	$k = 8.99 \times 10^9 \text{ N m}^2 \text{ C}^{-2}$
Planck's constant	$h = 6.63 \times 10^{-34} \text{ J s}$ $h = 4.14 \times 10^{-15} \text{ eV s}$

**Prefixes/Units**

p = pico = $10^{-12}$	n = nano = $10^{-9}$	$\mu$ = micro = $10^{-6}$	m = milli = $10^{-3}$
k = kilo = $10^3$	M = mega = $10^6$	G = giga = $10^9$	t = tonne = $10^3 \text{ kg}$

**End of Formula Sheet for the 2024 - 2027 Kilbaha VCE Units 3 and 4 Physics Examination**

Kilbaha Education (Est. 1978) (ABN 47 065 111 373) PO Box 3229 Cotham Vic 3101 Australia	PayID: 47065111373 Email: <a href="mailto:kilbaha@gmail.com">kilbaha@gmail.com</a> Tel: (03) 9018 5376 Web: <a href="https://kilbaha.com.au">https://kilbaha.com.au</a>
---	--