

Trial Examination 2021

VCE Physics Units 1&2

Written Examination

Question and Answer Booklet

Reading time: 15 minutes

Writing time: 2 hours 30 minutes

Student's Name: _____

Teacher's Name: _____

Structure of booklet

<i>Section</i>	<i>Number of questions</i>	<i>Number of questions to be answered</i>	<i>Number of marks</i>
A	20	20	20
B	14	14	110
			Total 130

Students are permitted to bring into the examination room: pens, pencils, highlighters, erasers, sharpeners, rulers, pre-written notes (one folded A3 sheet or two A4 sheets bound together by tape) and one scientific calculator.

Students are NOT permitted to bring into the examination room: blank sheets of paper and/or correction fluid/tape.

Materials supplied

Question and answer booklet of 29 pages

Formula sheet

Answer sheet for multiple-choice questions

Instructions

Write your **name** and your **teacher's name** in the space provided above on this page, and on the answer sheet for multiple-choice questions.

Unless otherwise indicated, the diagrams in this booklet are **not** drawn to scale.

All written responses must be in English.

At the end of the examination

Place the answer sheet for multiple-choice questions inside the front cover of this booklet.

You may keep the formula sheet.

Students are NOT permitted to bring mobile phones and/or any other unauthorised electronic devices into the examination room.

SECTION A – MULTIPLE-CHOICE QUESTIONS**Instructions for Section A**

Answer **all** questions in pencil on the answer sheet provided for multiple-choice questions.

Choose the response that is **correct** or that **best answers** the question.

A correct answer scores 1; an incorrect answer scores 0.

Marks will **not** be deducted for incorrect answers.

No marks will be given if more than one answer is completed for any question.

Unless otherwise indicated, the diagrams in this booklet are **not** drawn to scale.

Take the value of g to be 9.8 m s^{-2} .

Question 1

Which one of the following diagrams correctly represents the flow of heat?

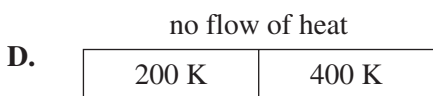
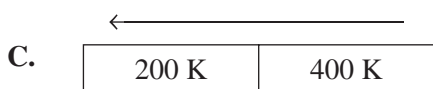
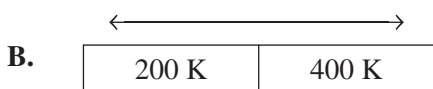
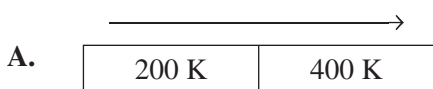
**Question 2**

A balloon reaches an internal energy of 35 J and expands using 15 J.

What is the heat transfer to the system?

- A. -50 J
- B. -20 J
- C. 20 J
- D. 50 J

Question 3

In an experiment, 900 g of aluminium is heated to 90.0°C. It is then dropped into 1.00 L of water with a temperature of 15.0°C.

Data

$C_{\text{aluminium}}$	$880 \text{ J kg}^{-1} \text{ }^\circ\text{C}^{-1}$
C_{water}	$4200 \text{ J kg}^{-1} \text{ }^\circ\text{C}^{-1}$
density of water	1 g mL^{-1}

The final temperature of the water and aluminium is closest to

- A. 27.0°C
- B. 31.0°C
- C. 38.0°C
- D. 39.0°C

Question 4

In the circuits shown below, each battery is 1.0 V and each resistor is 1.0 Ω .

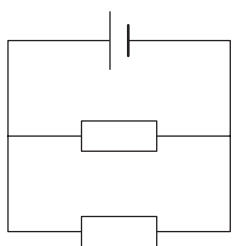

circuit X

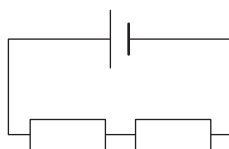

circuit Y

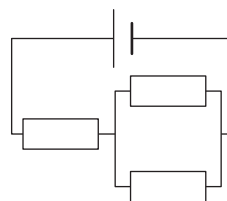

circuit Z

Which one of the following correctly orders the total power output of the circuits from lowest to highest?

- A. X, Y, Z
- B. Z, X, Y
- C. Y, Z, X
- D. Y, X, Z

Question 5

A household uses 4800 W of electric power during the 2-hour period from 6:00 pm to 8:00 pm. The amount of power used is the same every night. The cost of energy is 25.5 cents per kWh.

What is the total cost of energy consumed between 6:00 pm to 8:00 pm over a 2-week period?

- A. \$2.45
- B. \$13.44
- C. \$34.27
- D. \$134.40

Question 6

Consider the following decay equations.

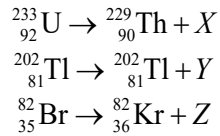

X , Y and Z respectively are

- A. alpha, beta, gamma.
- B. beta, gamma, alpha.
- C. gamma, alpha, beta.
- D. alpha, gamma, beta.

Question 7

A 200 W slow cooker and a 500 W kettle are both plugged into a 240 V DC power supply.

When the appliances are compared, the

- A. $I_{\text{slow cooker}} > I_{\text{kettle}}$ and the $R_{\text{slow cooker}} > R_{\text{kettle}}$.
- B. $I_{\text{slow cooker}} < I_{\text{kettle}}$ and the $R_{\text{slow cooker}} > R_{\text{kettle}}$.
- C. $I_{\text{slow cooker}} > I_{\text{kettle}}$ and the $R_{\text{slow cooker}} < R_{\text{kettle}}$.
- D. $I_{\text{slow cooker}} < I_{\text{kettle}}$ and the $R_{\text{slow cooker}} < R_{\text{kettle}}$.

Question 8

Two types of quarks and their respective charges are shown below.

Quark	Charge	Symbol
up	$+\frac{2}{3}$	u
down	$-\frac{1}{3}$	d

A quark with the composition up, down, down (udd) transforms into a particle with the quark composition up, up, down (uud).

The other particle produced in this transformation is

- A. a positron.
- B. an electron.
- C. a proton.
- D. a neutron.

Question 9

A refrigerator is required to maintain a temperature below 10°C. The cooling unit of the refrigerator is controlled by a thermistor using the circuit shown below. To turn the cooling unit on, a voltage of 8.0 V is required across the thermistor.

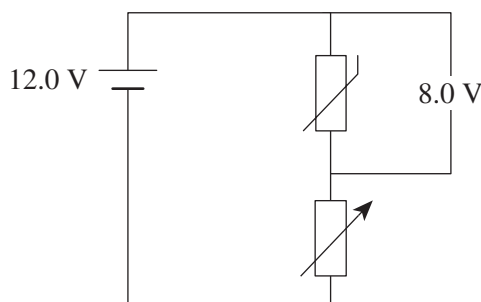

The resistance versus temperature characteristic curve of a thermistor is shown below.

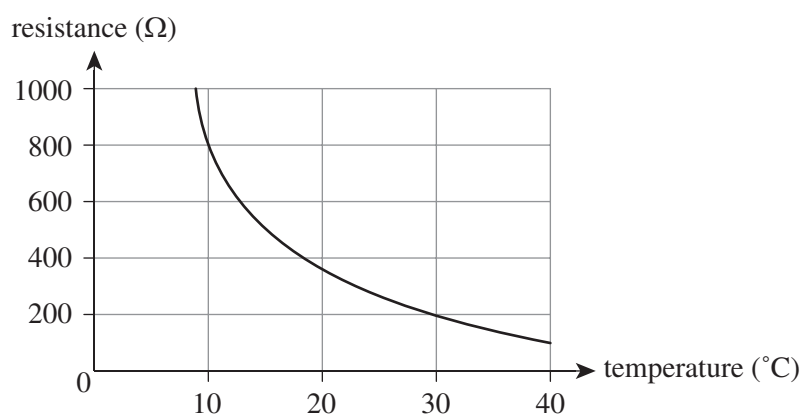

What is the value of the variable resistor shown above when the voltage across the thermistor is 8.0 V?

- A. 100 Ω
- B. 400 Ω
- C. 600 Ω
- D. 800 Ω

Question 10

The stable isotope boron-10 is bombarded with neutrons and transforms into lithium-7 by emitting an alpha particle, as shown below.

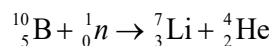

This is an example of

- A. fission.
- B. fusion.
- C. artificial transmutation.
- D. natural transmutation.

Question 11

Two cars, L and M, are travelling towards an intersection, as shown in the diagram below.

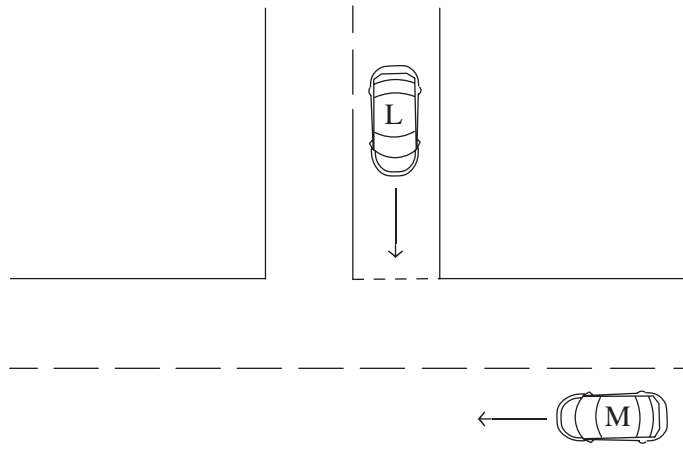

The velocity of car L is v_L , and the velocity of car M is v_M .

Which one of the following vectors best represents the velocity of car M relative to car L, that is, $v_L - v_M$?

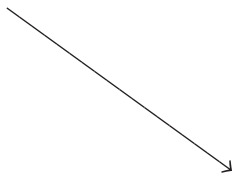
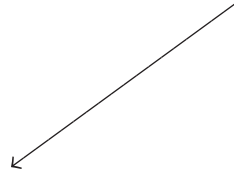
- A.** 
- C.** 

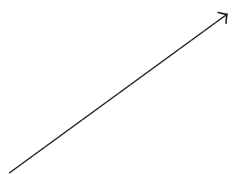
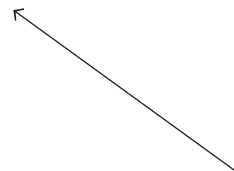
- B.** 
- D.** 

Question 12

The following displacement versus time graph represents the behaviour of a glider along a linear air track.

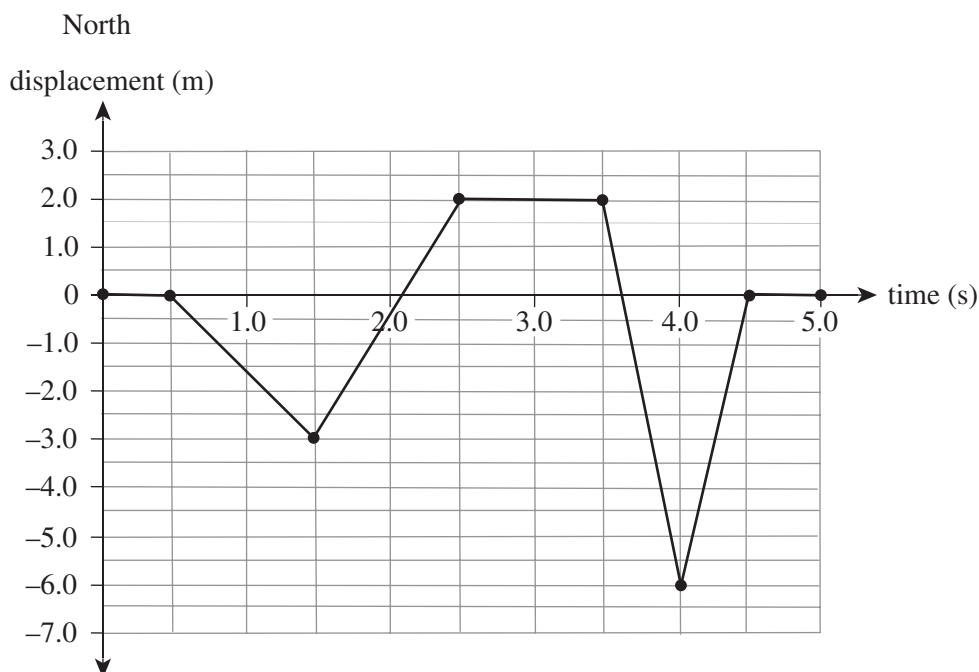

The total distance travelled by the glider is

- A. 0.0 m
- B. 13.0 m
- C. 19.0 m
- D. 22.0 m

Question 13

Which one of the following statements is correct?

- A. A 2 kg bag of rice has more inertia than a 10 kg bag of rice.
- B. A bowling ball has the same amount of inertia as a pencil.
- C. A feather has less inertia than a hammer.
- D. All bodies have the same inertia if they are close to the surface of the Earth, as they all have the same acceleration of 9.8 m s^{-2} due to gravity.

Question 14

A chair of mass 20.0 kg is pushed to the right by an unknown applied force, F . A friction force of 15.0 N acts on the chair.

If the chair is accelerating at 2.0 m s^{-2} , what is the value of F ?

- A. 25.0 N
- B. 30.0 N
- C. 40.0 N
- D. 55.0 N

Question 15

A viewing platform is installed at a national park. The platform can be considered as a long beam of uniform mass that extends 8.0 m beyond two vertical supports to which it is attached, as shown in the diagram below. The supports, X and Y, are 6.0 m apart.

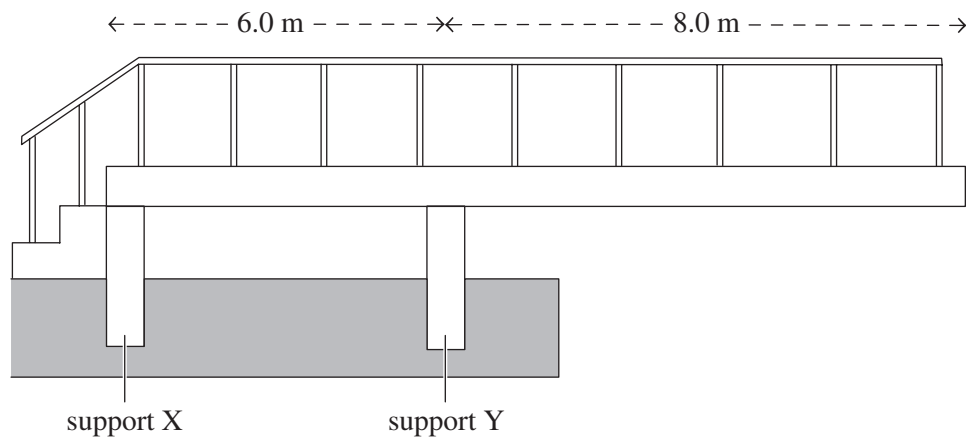

Which one of the following statements is correct?

- A. Support X is under compression, and support Y is under tension.
- B. Support X is under tension, and support Y is under compression.
- C. Both supports X and Y are under tension.
- D. Both supports X and Y are under compression.

Question 16

Two boxes, S and R, are in contact with each other on a frictionless surface. A constant horizontal force of 60.0 N is applied to box R, as shown in the diagram below. Box S has a mass of 2.0 kg, and box R has a mass of 4.0 kg.

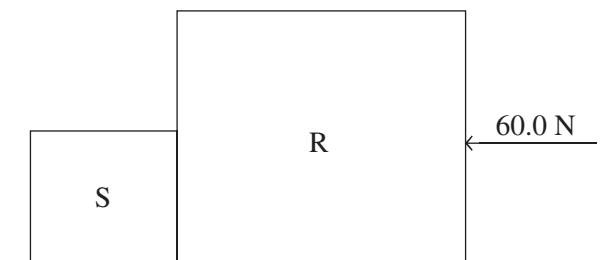

What is the magnitude of the force exerted by box R on box S?

- A. 0.0 N
- B. 20.0 N
- C. 40.0 N
- D. 60.0 N

Question 17

Which one of the following best describes a dependent variable?

- A. a variable that is fixed by a scientist in an experiment
- B. a variable that is selected and changed by a scientist in an experiment
- C. a variable measured by a scientist in an experiment
- D. a variable determined by a scientist to be unrelated to their experiment

Question 18

A ball of mass 2.00 kg is dropped on a patch of grass. The following graph shows the net force acting onto the ball when it hits grass.

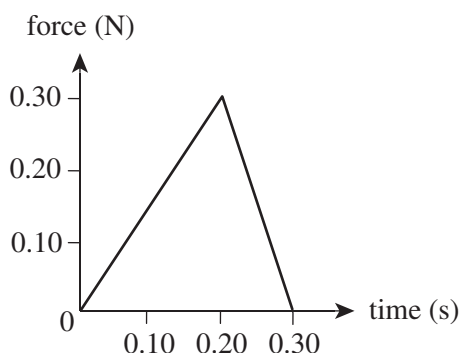

The magnitude of the impulse on the ball is closest to

- A. 4.5×10^{-2} N s
- B. 9.0×10^{-2} N s
- C. 1.8×10^{-1} N s
- D. 6.0×10^{-1} N s

Question 19

Cameron drags a cricket bag of mass 5.0 kg for 10.0 m across a rough surface with a force of 50.0 N. A frictional force of 20.0 N acts on the bag.

The work done by Cameron to oppose the bag's weight force is closest to

- A. 0.0 N
- B. 200 N
- C. 300 N
- D. 500 N

Question 20

Four students attend an archery class. They each shoot four arrows at their targets, then remove the arrows to check their results.

Which one of the following sets of results can be described as accurate but not precise?

A.

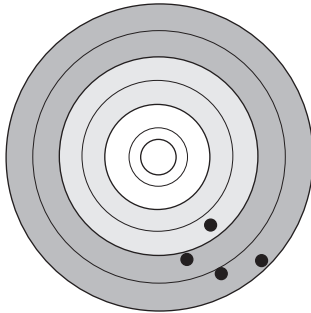

B.

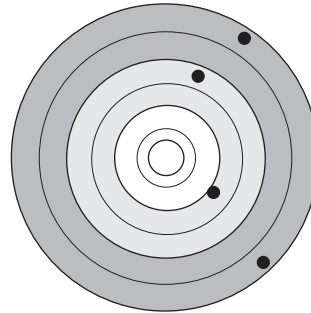

C.

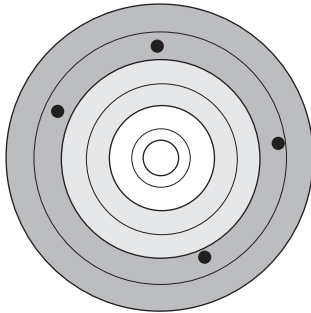

D.

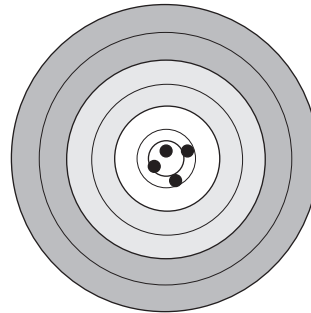

SECTION B**Instructions for Section B**

Answer **all** questions in the spaces provided.

Where an answer box is provided, write your final answer in the box.

If an answer box has a unit printed in it, give your answer in that unit.

In questions where more than one mark is available, appropriate working **must** be shown.

Unless otherwise indicated, the diagrams in this booklet are **not** drawn to scale.

Take the value of g to be 9.8 m s^{-2} .

Question 1 (5 marks)

A piece of copper of unknown mass absorbs 2000 J of energy and undergoes a temperature change from 375 K to 475 K.

$$C_{\text{copper}} = 385 \text{ J kg}^{-1} \text{ }^{\circ}\text{C}^{-1}$$

- a. What is the mass of the piece of copper, correct to three significant figures? Show your working.

3 marks

kg

- b. Is this process endothermic or exothermic? Give your reasoning.

2 marks

Question 2 (8 marks)

Figure 1 shows the cooling curve for a 50 g sample of an unknown substance.

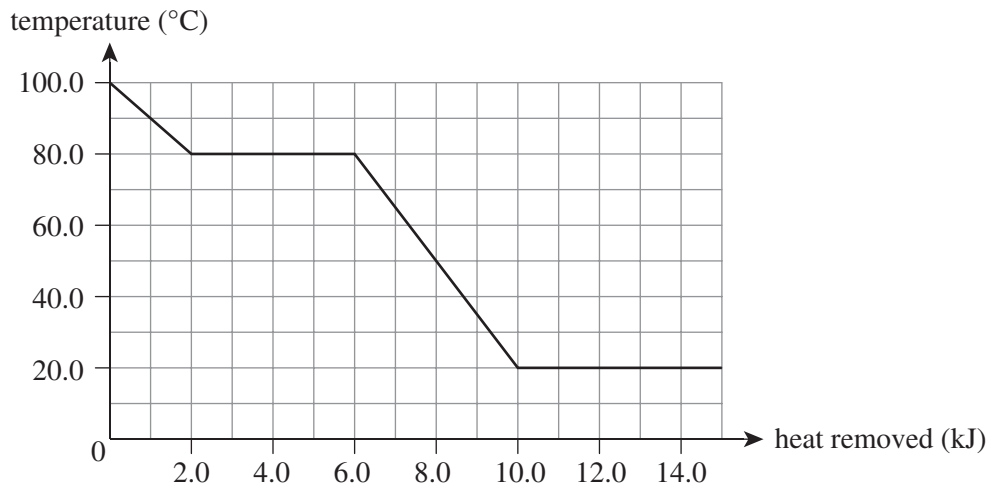
**Figure 1**

- a. What is the freezing point for the sample, in Kelvin? 2 marks

K

- b. What happens to the sample when it reaches 80°C? 2 marks

- c. Calculate the latent heat of vaporisation, L_v , for the sample. 2 marks

J kg^{-1}

- d. Calculate the specific heat capacity of the sample while it is a liquid. 2 marks

$\text{J kg}^{-1} \text{ } ^\circ\text{C}$

Question 3 (4 marks)

The Sun is a yellow star with a peak intensity at about 635 nm.

What is the temperature of the surface of the Sun?

$^\circ\text{C}$

Question 4 (4 marks)

A cup of water and a swimming pool of water are both at the same temperature.

- a. i.** Is the average kinetic energy of the cup of water greater than, equal to or less than the average kinetic energy of the swimming pool of water? 1 mark

-
- ii.** Is the internal energy of the cup of water greater than, equal to or less than the internal energy of the swimming pool of water? 1 mark

-
- b.** Explain your reasoning for the answers given in **part a.** 2 marks

Question 6 (7 marks)

The current versus voltage graph for a diode is shown in Figure 3.

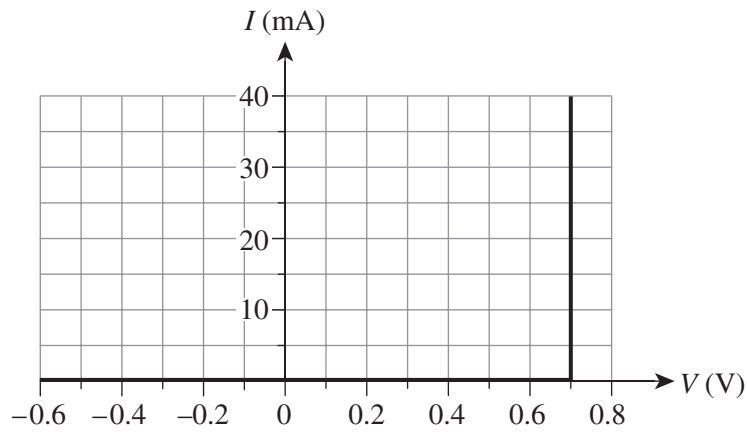

Figure 3

The diode is placed in the circuit shown in Figure 4.

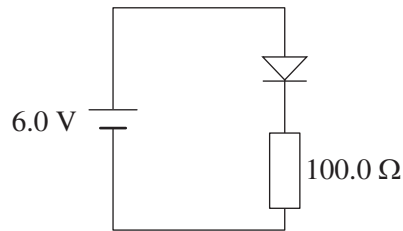

Figure 4

- a. What is the potential difference across the diode? 1 mark

V

- b. What is the potential difference across the 100 Ω resistor? 1 mark

V

- c. What is the current flowing in the circuit? 3 marks

mA

- d. The diode is reversed, as shown in Figure 5.

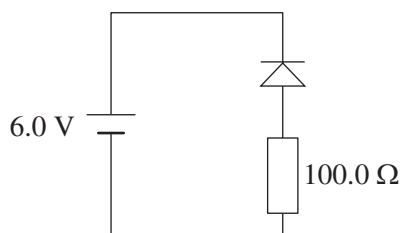

Figure 5

What is the new potential difference across the diode? Explain your reasoning.

2 marks

V

Question 7 (5 marks)

Some appliances are double insulated and do not need an earth pin.

- a. What does it mean when an appliance is double insulated? In your answer, identify the role of each layer of insulation.

3 marks

- b. Explain why an earth pin is **not** needed for double insulated appliances.

2 marks

Question 8 (7 marks)

Uranium-238 decays into thorium-234 and an alpha particle, as shown in Figure 6.

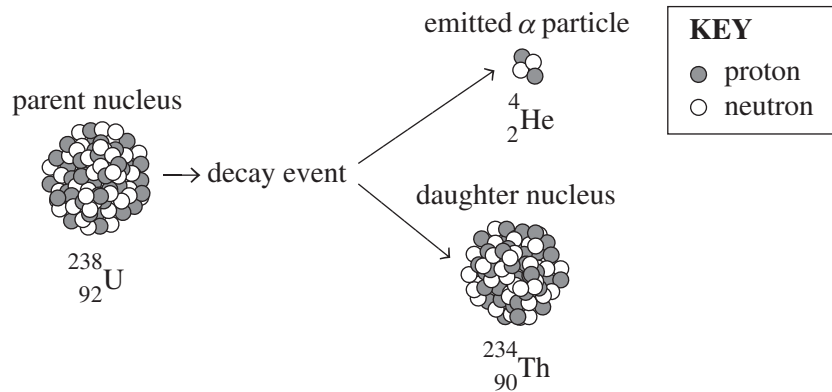

Figure 6

Consider the following data.

Data

$^{238}_{92}\text{U} = 238.0508 \text{ u}$
$^{234}_{90}\text{Th} = 234.0426 \text{ u}$
$^4_2\alpha = 4.0026 \text{ u}$
$\text{u} = 1.6605 \times 10^{-27} \text{ kg}$

- a. Write down the full decay equation for uranium-238. 2 marks

- b. Calculate the energy released by the decay equation in **part a**. 5 marks

eV

Question 9 (9 marks)

Figure 7 shows the decay curve for iodine-131, which is a radioactive iodine salt that alters the mechanism of iodine absorption in the thyroid gland. Radioactive isotopes with relatively short half-lives, such as iodine-131, are often used for medical diagnosis and treatment. It is particularly useful for the destruction of overactive cells in the thyroid gland.

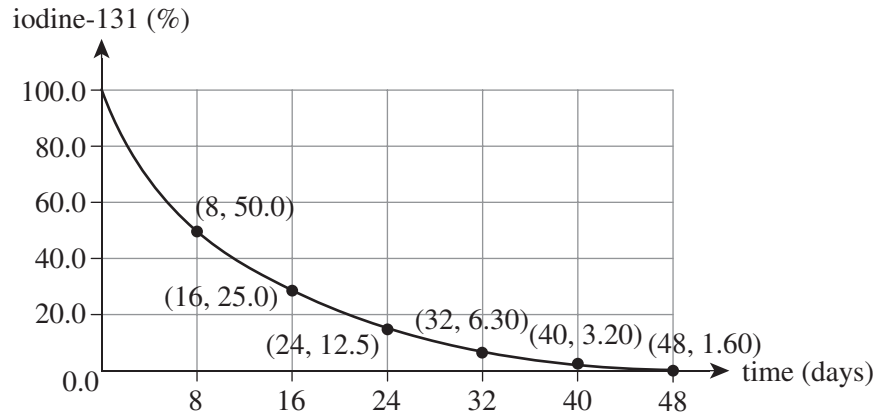
**Figure 7**

- a. Using Figure 7, estimate the half-life of iodine-131. 1 mark

days

- b. A patient is administered a dose of this isotope of iodine-131.
 What percentage of iodine-131 will remain in the patient's system after 32 days?
 Show your working. 2 marks

%

- c. Explain why radioactive isotopes with relatively short half-lives are desirable for medical diagnostic and treatment purposes. 2 marks

d. Iodine-131 is a beta-minus emitter.

How does beta-minus radiation compare with alpha radiation in terms of mass, charge, penetrating ability and ionising ability?

4 marks

Mass _____

Charge _____

Penetrating ability _____

Ionising ability _____

Question 10 (3 marks)

Ethan sits stationary on a park bench. His weight pulls him downwards, and the park bench pushes upwards against him.

Explain whether the force of Ethan’s weight pulling him downwards and the force of the park bench pushing upwards against him are or are not an action–reaction pair in terms of Newton’s third law.

Question 11 (12 marks)

On a main road, a car of mass 1.0×10^3 kg and a minibus of mass 6.0×10^3 kg are travelling south. The car is travelling at a velocity of 25.0 m s^{-1} , and the minibus is travelling at a velocity of 11.0 m s^{-1} in front of the car, as shown in Figure 8a. The car collides with the back of the minibus, and the vehicles become coupled after the minor rear-end collision, as shown in Figure 8b.

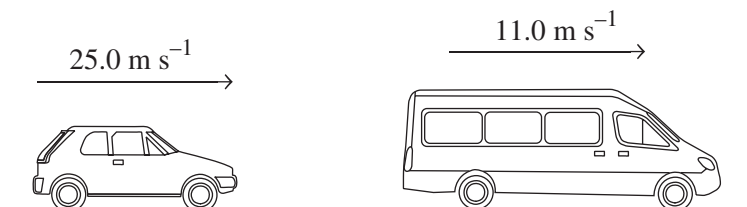
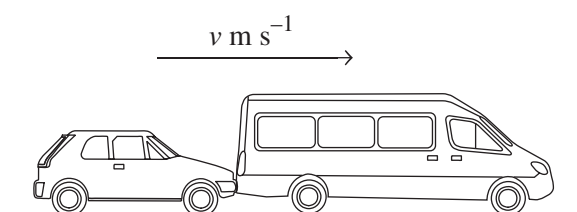
**Figure 8a****Figure 8b**

- a. Show that the common velocity of the coupled vehicles is 13 m s^{-1} .
Show your working. 2 marks

- b. i. Calculate the change in momentum of the car. Show your working. 2 marks

kg m s^{-1}

- ii.** Calculate the change in momentum of the minibus. Show your working. 2 marks

kg m s^{-1}

- c.** The coupled vehicles eventually come to rest.
Explain where the momentum of the coupled vehicles is transferred. 2 marks

Modern vehicles have design features that extend collision time.

A vehicle safety authority conducts a crash test for a new car model. A crash test dummy is placed in the driver's seat, and the car is crashed into the wall under controlled conditions.

- d. i.** If the time of impact of a collision were increased by a factor of 4, explain how the force of impact acting on the crash test dummy would be affected for the same change in momentum. Explain your reasoning. 2 marks

- ii.** In terms of momentum, explain how crumple zones work and how they can reduce the severity of injuries inflicted on a car's occupants in a collision. 2 marks

Question 12 (10 marks)

At a mail sorting centre, large packages are slid down a ramp onto a conveyor belt for sorting. A 5.0 kg box slides down the ramp, which is a plane inclined at an angle of 30° , as shown in Figure 9. The magnitude of the frictional force acting on the box is 10.0 N.

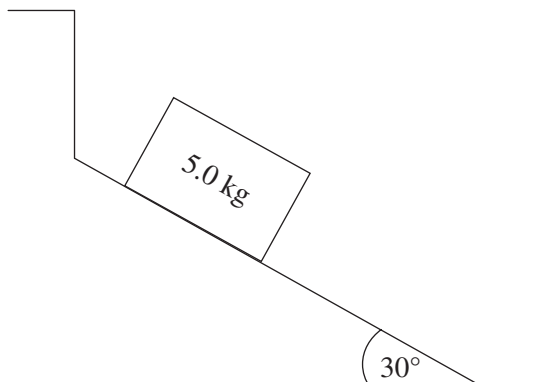
**Figure 9**

- a. On Figure 9, draw and label the forces acting on the box. 3 marks
- b. Calculate the magnitude of the normal force acting on the box. Show your working. 2 marks

N

- c. Determine the magnitude of the average acceleration of the box. Show your working. 3 marks

m s^{-2}

- d.** Determine the work done by the frictional force in slowing down the box over a distance of 5.0 m. Show your working.

2 marks

J

Question 13 (14 marks)

A student conducts an experiment where they attach various hanging masses to a suspended spring and measure the resulting total length of the spring. Table 1 shows some of the data for the experiment.

Table 1

Hanging mass (g)	Weight of hanging mass (N)	Total length of spring (cm) ± 1.0 cm
50.0	0.49	37.0
100.0		42.0
150.0		49.0
200.0		54.0
250.0		61.0
300.0		70.0

- a. In the table below, identify the variables in the experiment. 3 marks

Classification	Variable
independent	
dependent	
controlled	

- b. i. Show that the weight of the 50.0 g hanging mass is 0.49 N. Show your working. 1 mark

- ii. Calculate the weights of the hanging masses and write them in the spaces provided in Table 1. 3 marks

- c. Plot a graph of the weights of the hanging masses on the y -axis against the total spring length on the x -axis. On your graph:
- draw a line of best fit through the plotted points
 - include uncertainty bars ($\pm x$ -direction only) of ± 1.0 cm. (Uncertainty bars in the y -direction are not required.)
- 3 marks

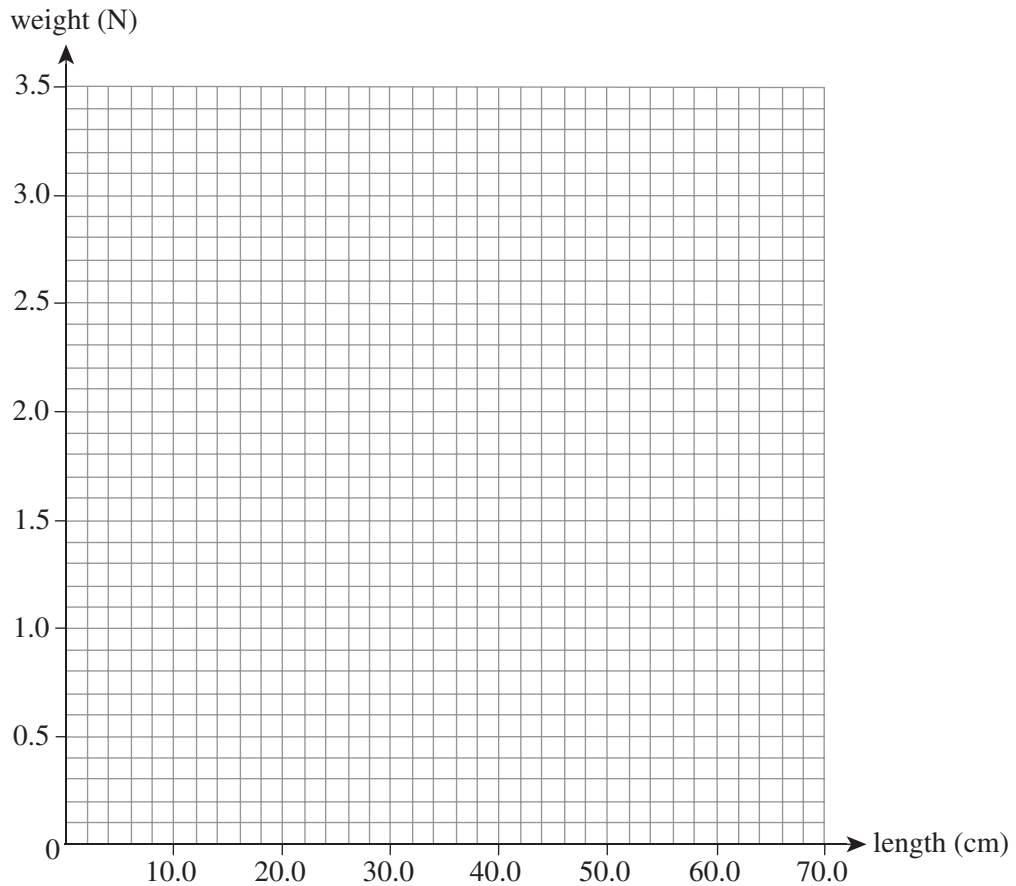

- d. Use the graph drawn in **part c.** to find the original length of the spring before any mass was attached to it. 1 mark

cm

- e. Calculate the spring constant of the spring. Show your working. Do not calculate any uncertainties. 2 marks

N m^{-1}

- f. What would be the force in the spring if it were stretched by 20 cm? Do not calculate any uncertainties. 1 mark

N

Question 14 (16 marks)

Figure 10 shows how velocity varies with time for a model car travelling back and forth along a straight line. Travelling West is positive in direction.

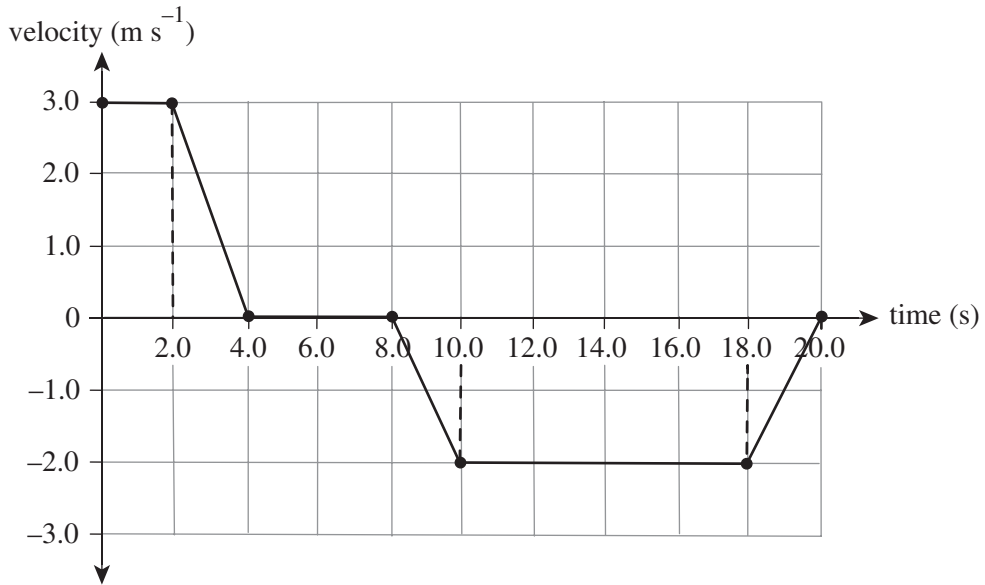

Figure 10

- a. Determine the magnitude and direction of the model car's velocity 11.0 s after starting its motion. If the direction is not applicable, write N/A in the answer box. 2 marks

m s^{-1}	
-------------------	--

- b. Determine the magnitude and direction of the model car's acceleration 19.0 s after starting its motion. Show your working. If the direction is not applicable, write N/A in the answer box. 3 marks

m s^{-2}	
-------------------	--

- c.** Determine the magnitude and direction of the distance that the model car travels in 20.0 s. Show your working. If the direction is not applicable, write N/A in the answer box. 3 marks

m	
---	--

- d.** Determine the magnitude and direction of the object's final displacement from its starting point. Show your working. If the direction is not applicable, write N/A in the answer box. 3 marks

m	
---	--

- e. On the grid provided below, sketch a corresponding acceleration versus time graph for the model car's motion. Include appropriate axis labels, scales and units.

5 marks

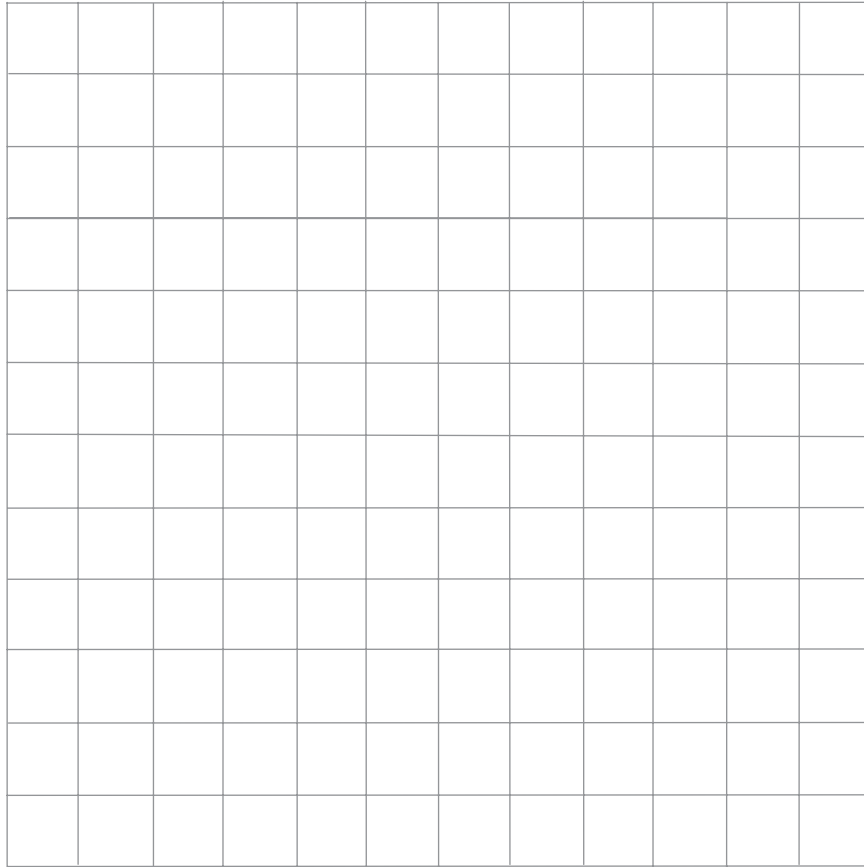

END OF QUESTION AND ANSWER BOOKLET

Trial Examination 2021

VCE Physics Units 1&2

Written Examination

Formula Sheet

Instructions

This formula sheet is provided for your reference.
A question and answer booklet is provided with this formula sheet.

Students are NOT permitted to bring mobile phones and/or any other unauthorised electronic devices into the examination room.

PHYSICS FORMULAS

specific heat	$Q = mc\Delta t$
latent heat	$Q = mL$
Wien's law	$\lambda_{\max} T = 2.9 \times 10^{-3} \text{ mK}$
Stefan–Boltzmann law	$P = \sigma T^4$ where Stefan–Boltzmann constant $\sigma = 5.67 \times 10^{-8} \text{ W m}^{-2} \text{ K}^4$
first law of thermodynamics	$\Delta U = Q - W$
mass–energy equation	$E = mc^2$
power	$P = \frac{E}{t}$ or $P = \frac{W}{\Delta t} = \frac{\Delta E}{\Delta t}$ or $P = Fv$
electrical charge	$Q = It$
electrical work	$W = QV$
voltage	$V = IR$
power	$P = VI$
resistors in series	$R_T = R_1 + R_2$
resistors in parallel	$\frac{1}{R_T} = \frac{1}{R_1} + \frac{1}{R_2}$
velocity; acceleration	$v = \frac{\Delta s}{\Delta t}$; $a = \frac{\Delta v}{\Delta t}$
equations for constant acceleration	$v = u + at$ $s = ut + \frac{1}{2}at^2$ $s = vt - \frac{1}{2}at^2$ $v^2 = u^2 + 2as$ $s = \frac{1}{2}(v + u)t$
Newton's second law	$\Sigma F = ma$
gravitational potential energy near the surface of Earth	$mg\Delta h$
kinetic energy	$\frac{1}{2}mv^2$
mechanical work	$W = Fs$

power	$P = \frac{W}{\Delta t} = \frac{\Delta E}{\Delta t}$
Hooke's law	$F = -k\Delta x$
elastic potential energy	$\frac{1}{2}k(\Delta x)^2$
torque	$\tau = F \times r$
momentum	mv
impulse	$F\Delta t$
efficiency	$\text{efficiency (\%)} = \frac{\text{useful energy output}}{\text{energy input}} \times 100$

Data

speed of light in a vacuum	$c = 3.0 \times 10^8 \text{ m s}^{-1}$
1 eV	$1.6 \times 10^{-19} \text{ J}$
charge on the electron	$e = 1.6 \times 10^{-19} \text{ C}$
acceleration due to gravity at Earth's surface	$g = 9.8 \text{ m s}^{-2}$

Prefixes/Units

p = pico = 10^{-12}	n = nano = 10^{-9}	μ = micro = 10^{-6}	m = milli = 10^{-3}
k = kilo = 10^3	M = mega = 10^6	G = giga = 10^9	t = tonne = 10^3 kg

Periodic table of the elements

atomic number		symbol of element		relative atomic mass		name of element																																																																																																																																																																													
1	H	2	He	3	Li	4	Be	5	B	6	C	7	N	8	O	9	F	10	Ne	11	Na	12	Mg	13	Al	14	Si	15	P	16	S	17	Cl	18	Ar	19	K	20	Ca	21	Sc	22	Ti	23	V	24	Cr	25	Mn	26	Fe	27	Co	28	Ni	29	Cu	30	Zn	31	Ga	32	Ge	33	As	34	Se	35	Br	36	Kr	37	Rb	38	Sr	39	Y	40	Zr	41	Nb	42	Mo	43	Tc	44	Ru	45	Rh	46	Pd	47	Ag	48	Cd	49	In	50	Sn	51	Sb	52	Te	53	I	54	Xe	55	Cs	56	Ba	57-71	lanthanoids	72	Hf	73	Ta	74	W	75	Re	76	Os	77	Ir	78	Pt	79	Au	80	Hg	81	Tl	82	Pb	83	Bi	84	Po	85	At	86	Rn	87	Fr	88	Ra	89-103	actinoids	104	Rf	105	Db	106	Sg	107	Bh	108	Hs	109	Mt	110	Ds	111	Rg	112	Cn	113	Nh	114	Fl	115	Mc	116	Lv	117	Ts	118	Og

57	La	58	Ce	59	Pr	60	Nd	61	Pm	62	Sm	63	Eu	64	Gd	65	Tb	66	Dy	67	Ho	68	Er	69	Tm	70	Yb	71	Lu
89	Ac	90	Th	91	Pa	92	U	93	Np	94	Pu	95	Am	96	Cm	97	Bk	98	Cf	99	Es	100	Fm	101	Md	102	No	103	Lr

The value in the brackets indicates the mass number of the longest-lived isotope.

END OF FORMULA SHEET

VCE Physics Units 1&2

Written Examination

Multiple-choice Answer Sheet

Student's Name: _____

Teacher's Name: _____

Instructions

Use a **pencil** for **all** entries. If you make a mistake, **erase** the incorrect answer – **do not** cross it out. Marks will **not** be deducted for incorrect answers.

No mark will be given if more than **one** answer is completed for any question.

All answers must be completed like this example:

A	B	C	D
---	---	---	---

Use pencil only

1	A	B	C	D	11	A	B	C	D
2	A	B	C	D	12	A	B	C	D
3	A	B	C	D	13	A	B	C	D
4	A	B	C	D	14	A	B	C	D
5	A	B	C	D	15	A	B	C	D
6	A	B	C	D	16	A	B	C	D
7	A	B	C	D	17	A	B	C	D
8	A	B	C	D	18	A	B	C	D
9	A	B	C	D	19	A	B	C	D
10	A	B	C	D	20	A	B	C	D