

Trial Examination 2018

VCE Physics Units 3&4

Written Examination

Question and Answer Booklet

Reading time: 15 minutes

Writing time: 2 hours 30 minutes

Student's Name: _____

Teacher's Name: _____

Structure of booklet

<i>Section</i>	<i>Number of questions</i>	<i>Number of questions to be answered</i>	<i>Number of marks</i>
A	20	20	20
B	17	17	110
			Total 130

Students are permitted to bring into the examination room: pens, pencils, highlighters, erasers, sharpeners, rulers, pre-written notes (one folded A3 sheet or two A4 sheets bound together by tape) and one scientific calculator.

Students are NOT permitted to bring into the examination room: blank sheets of paper and/or correction fluid/tape.

Materials supplied

Question and answer booklet of 37 pages

Formula sheet

Answer sheet for multiple-choice questions

Instructions

Write your **name** and your **teacher's name** in the space provided above on this page, and on the answer sheet for multiple-choice questions.

Unless otherwise indicated, the diagrams in this booklet are **not** drawn to scale.

All written responses must be in English.

At the end of the examination

Place the answer sheet for multiple-choice questions inside the front cover of this booklet.

You may keep the formula sheet.

Students are NOT permitted to bring mobile phones and/or any other unauthorised electronic devices into the examination room.

Students are advised that this is a trial examination only and cannot in any way guarantee the content or the format of the 2018 VCE Physics Units 3&4 Written Examination.

Neap Trial Exams are licensed to be photocopied or placed on the school intranet and used only within the confines of the school purchasing them, for the purpose of examining that school's students only. They may not be otherwise reproduced or distributed. The copyright of Neap Trial Exams remains with Neap. No Neap Trial Exam or any part thereof is to be issued or passed on by any person to any party inclusive of other schools, non-practising teachers, coaching colleges, tutors, parents, students, publishing agencies or websites without the express written consent of Neap.

SECTION A – MULTIPLE-CHOICE QUESTIONS**Instructions for Section A**

Answer **all** questions in pencil on the answer sheet provided for multiple-choice questions.

Choose the response that is **correct** or that **best answers** the question.

A correct answer scores 1; an incorrect answer scores 0.

Marks will **not** be deducted for incorrect answers.

No marks will be given if more than one answer is completed for any question.

Unless otherwise indicated, the diagrams in this booklet are **not** drawn to scale.

Take the value of g to be 9.8 m s^{-2} .

Use the following information to answer Questions 1 and 2.

The diagram below shows two plates, A and B, which have potentials of -12 V and $+6 \text{ V}$ respectively.

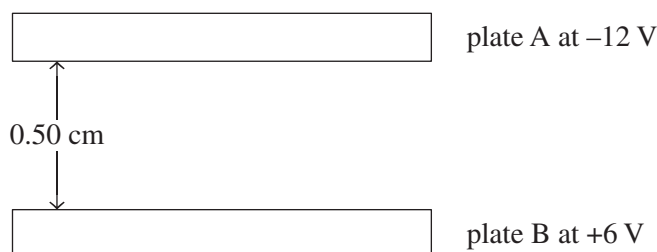

The plates have a separation of 0.50 cm .

Question 1

What is the electric field strength midway between the two plates?

- A. 36 N C^{-1}
- B. 360 N C^{-1}
- C. 3600 N C^{-1}
- D. $36\,000 \text{ N C}^{-1}$

Question 2

How much kinetic energy does an electron gain from being placed at rest midway between the two plates to when it strikes one of the plates upon release?

- A. $1.44 \times 10^{-18} \text{ J}$
- B. $1.92 \times 10^{-18} \text{ J}$
- C. $2.88 \times 10^{-18} \text{ J}$
- D. $9.6 \times 10^{-19} \text{ J}$

Question 3

An electron is fired with a momentum of 1.37×10^{-22} N s into a region of magnetic field of magnitude 5.0 T, as shown in the diagram below.

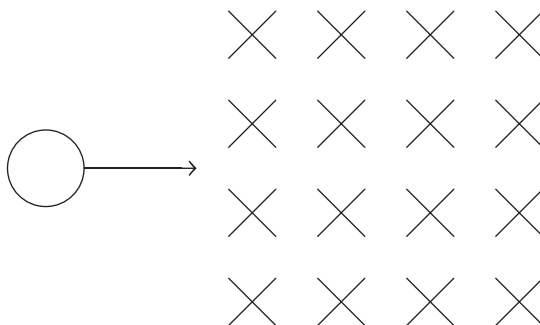

The electron initially moves

- A. upwards in a circular path of radius 0.17 mm.
- B. downwards in a circular path of radius 0.17 mm.
- C. upwards in a circular path of radius 0.86 mm.
- D. downwards in a circular path of radius 0.86 mm.

Question 4

A simple, ideal step-down transformer has a turns ratio of 20 : 1. The transformer is in operation where currents exist in the primary and secondary side of the transformer.

Which one of the following gives the correct ratio for each quantity?

	Primary current : secondary current	Input power : output power
A.	20 : 1	20 : 1
B.	20 : 1	1 : 1
C.	1 : 20	1 : 20
D.	1 : 20	1 : 1

Question 5

A generator coil is turned at a constant rate as shown in the diagram below.

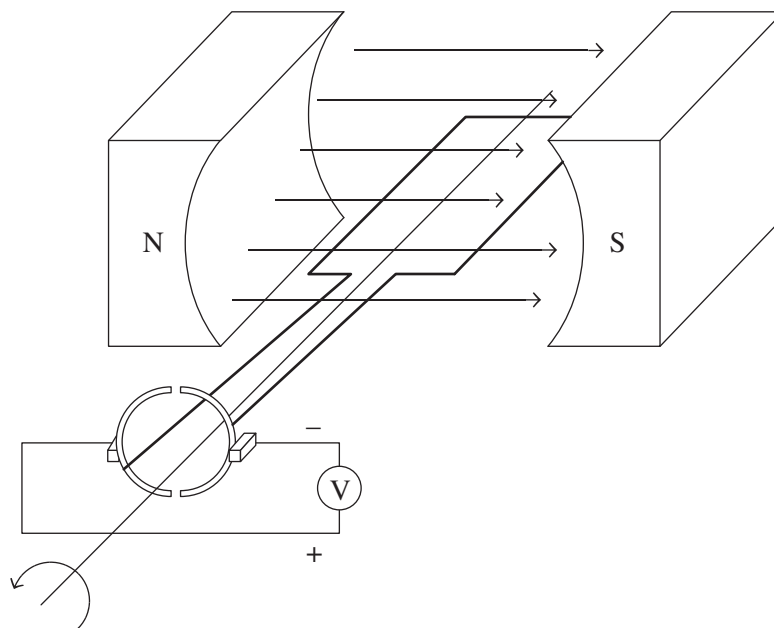

Which one of the following voltage–time graphs best represents the output from the generator?

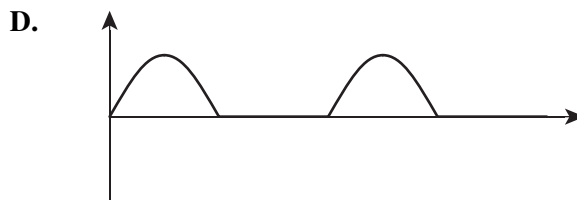
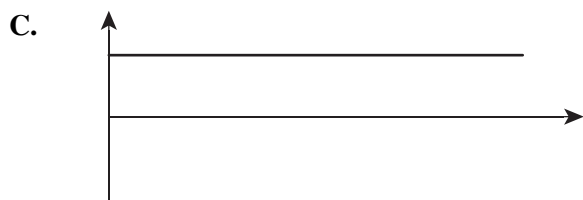
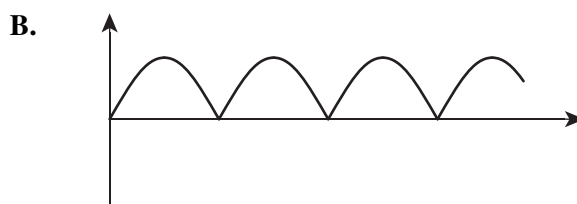
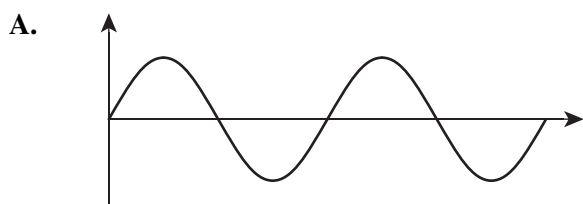

Question 6

The diagram below shows a 1.0 kg mass falling and pulling the 2.0 kg mass on a frictionless surface via a frictionless pulley.

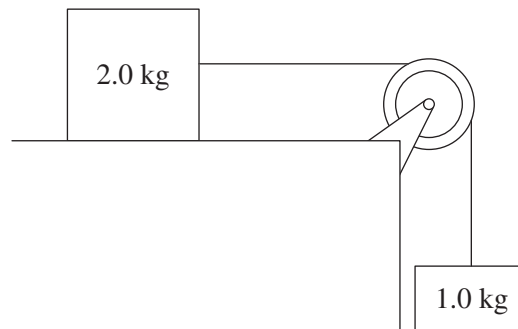

The best estimate of the tension in the cable connecting the two masses is

- A. 3.3 N
- B. 6.5 N
- C. 9.8 N
- D. 19.6 N

Question 7

An electron has a rest mass energy of 0.512 MeV.

If the electron travels with a Lorentz factor (γ) value of 2.5, its mass energy is

- A. 0.512 MeV
- B. 0.769 MeV
- C. 1.281 MeV
- D. 1.794 MeV

Use the following information to answer Questions 8 and 9.

A spring-loaded laboratory cart of mass 0.50 kg is pressed up against a wall such that its internal spring is compressed by 2.0 cm . When released, the spring unloads and the cart reaches a speed of 2.0 m s^{-1} as the spring returns to its original length. The spring is considered ideal.

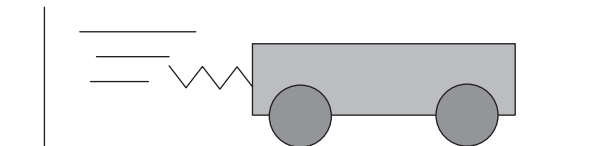

Question 8

The work done by the spring on the cart is

- A. 0.25 J
- B. 0.5 J
- C. 1.0 J
- D. 2.0 J

Question 9

Which one of the following graphs best represents the force–compression relationship for the spring?

A.

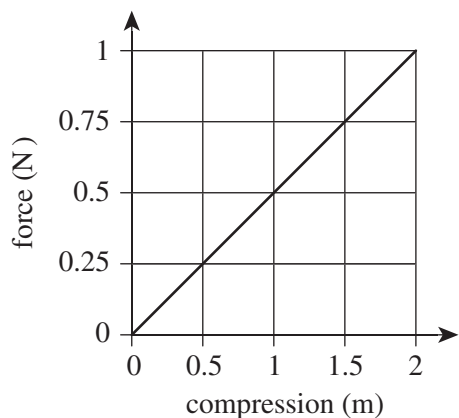

B.

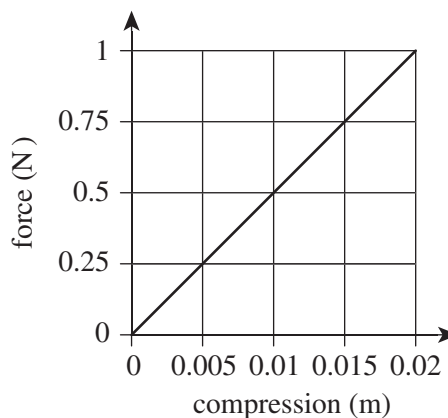

C.

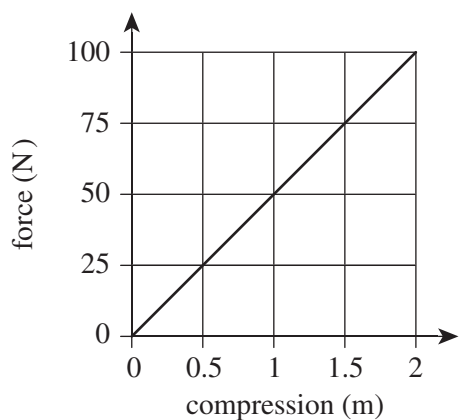

D.

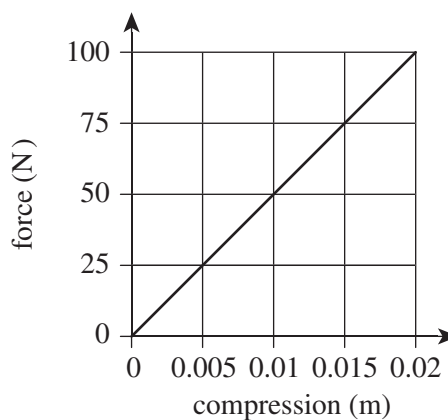

Question 10

A standing wave is formed on a rope of length 5.0 m which is tied at one end. A student's hand holds the other end and creates the standing wave as shown in the diagram below.

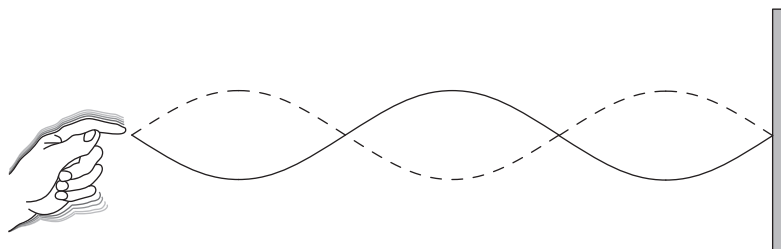

The speed of the wave in the rope is 25 m s^{-1} .

What are the three smallest frequencies that can exist in the rope?

- A. 2.5 Hz, 5.0 Hz, 7.5 Hz
- B. 5.0 Hz, 10.0 Hz, 15.0 Hz
- C. 2.5 Hz, 7.5 Hz, 12.5 Hz
- D. 5.0 Hz, 15.0 Hz, 25.0 Hz

Question 11

The polarisation of light can be best described as the manipulation of light so that its waves vibrate in

- A. random directions.
- B. two directions at right angles to each other.
- C. any two directions.
- D. a particular direction.

Question 12

Dispersion occurs when rays of different colours of light travelling initially as a single ray have different angles of refraction as they pass from one transparent medium into another.

The best reason for this explanation for dispersion is that

- A. it is a refraction effect.
- B. the speed of light varies for different colours in different media.
- C. the refractive index of a medium increases with the increase in the wavelength of light.
- D. the refractive index of a medium increases with the increase in the frequency of light.

Question 13

Which one of the following statements correctly identifies why an electron microscope that uses electrons to irradiate the surface of a small insect will produce a clearer image than an optical microscope that uses light?

- A. The de Broglie wavelength of the electrons is lesser than the optical wavelengths and so diffracts in a minimal manner, resulting in a clearer image.
- B. The de Broglie wavelength of the electrons is greater than the optical wavelengths and so diffracts more cleanly, resulting in a clearer image.
- C. Electrons carry charge that is used to produce a clearer image, whereas light does not.
- D. Electrons reflect more cleanly from the surface of the insect, whereas light interferes, leading to bright and dark spots on the image.

Question 14

An electromagnetic wave has a frequency of 3.0×10^{15} Hz.

Its wavelength and position in the electromagnetic spectrum are

- A. 100 nm and in the infrared region respectively.
- B. 100 nm and in the ultraviolet region respectively.
- C. 300 nm and in the infrared region respectively.
- D. 300 nm and in the ultraviolet region respectively.

Question 15

The production of light resulting from the forced change in direction of electrons due to action from a magnetic field occurs in

- A. LED sources.
- B. laser sources.
- C. incandescent globes.
- D. synchrotrons.

Question 16

A stream of electrons is directed through a narrow slit of width d , as shown in the diagram below. Directions y and x are also shown in the diagram.

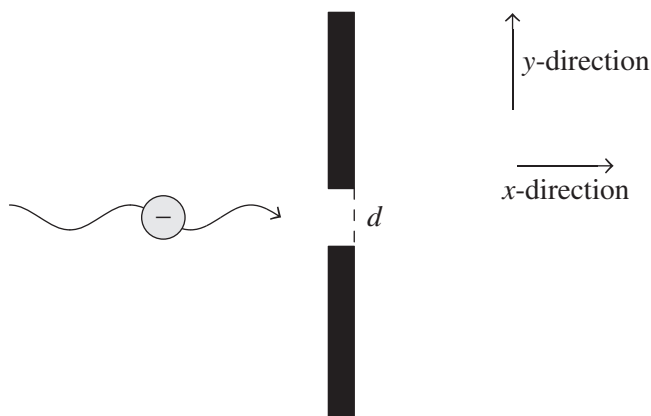

As d is decreased to reduce the uncertainty in the position of the electron as it passes through, the uncertainty in the momentum of the electron in the

- A. y -direction is increased.
- B. y -direction is decreased.
- C. x -direction is increased.
- D. x -direction is decreased.

Question 17

Young's double-slit experiment is performed as shown in the diagram below.

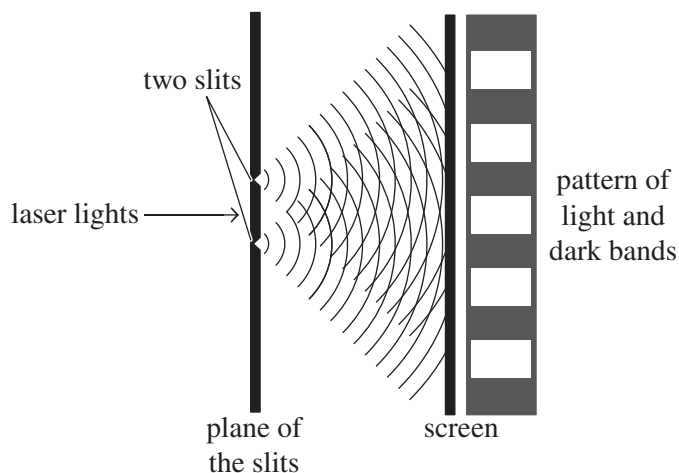

The experiment is repeated whereby the pattern of light and dark bands are now produced further apart.

Which one of the following represents the possible change to the parameters that would give this result?

- A. Light of greater frequency was used.
- B. The plane of the slits was brought closer to the screen.
- C. The two slits were moved further apart.
- D. The laser light was made more intense.

Question 18

A photon and an electron both have a wavelength of 2.0×10^{-10} m.

Which one of the following is correct?

- A. The electron and photon have the same momentum but the photon has more energy.
- B. The electron and photon have the same momentum but the photon has less energy.
- C. The electron and photon have the same energy but the photon has more momentum.
- D. The electron and photon have the same energy but the photon has more momentum.

Question 19

A group of students undertake an experiment to measure the refractive index of water. Their results conclude the refractive index to be $[1.35 \pm 0.15]$.

The accepted value of the refractive index of water is 1.33.

Which one of the following is correct regarding the uncertainty and the error of the result?

	Error	Uncertainty
A.	0.02	0.02
B.	0.02	0.15
C.	0.15	0.02
D.	0.15	0.15

Question 20

The table below has two sets of measurements, X and Y, of the length of a stick, and their averages.

	Measurements	Average
Set X	91.6 cm, 91.7 cm, 91.5 cm, 91.6 cm, 91.8 cm	91.6 cm
Set Y	83.4 cm, 92.3 cm, 87.5 cm, 90.2 cm, 85.6 cm	87.8 cm

The accepted length of the stick is 88.1 cm.

Which one of the following is correct regarding the measurements?

- A. Set X is precise and accurate.
- B. Set Y is precise and accurate.
- C. Set X is accurate and the average of set Y is precise.
- D. Set X is precise and the average of set Y is accurate.

SECTION B

Instructions for Section B

Answer **all** questions in the spaces provided. Write using blue or black pen.
 Where an answer box is provided, write your final answer in the box.
 If an answer box has a unit printed in it, give your answer in that unit.
 In questions where more than one mark is available, appropriate working **must** be shown.
 Unless otherwise indicated, the diagrams in this booklet are **not** drawn to scale.
 Take the value of g to be 9.8 m s^{-2} .

Question 1 (5 marks)

Two charges, Q_1 and Q_2 are 2.0 m apart. A third charge, Q_3 , that is equal in value and sign to Q_1 is exactly midway between both charges. This is shown in Figure 1.

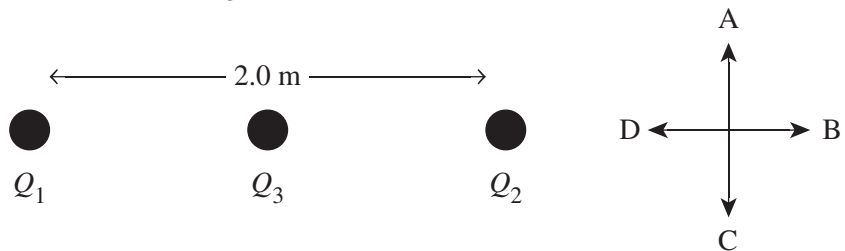

Figure 1

Q_1 and Q_3 have a charge of $1.49 \times 10^{-5} \text{ C}$. The force of Q_1 on Q_3 is 2.0 N to the right. The net force acting on Q_3 is 1.0 N to the left.

- a.** Determine the size and direction (A–D) of the force of Q_2 on Q_3 . 3 marks

N	Direction
---	-----------

- b.** Determine the value and sign of the charge Q_2 . 2 marks

C

Question 2 (5 marks)

An electric motor is shown in Figure 2.

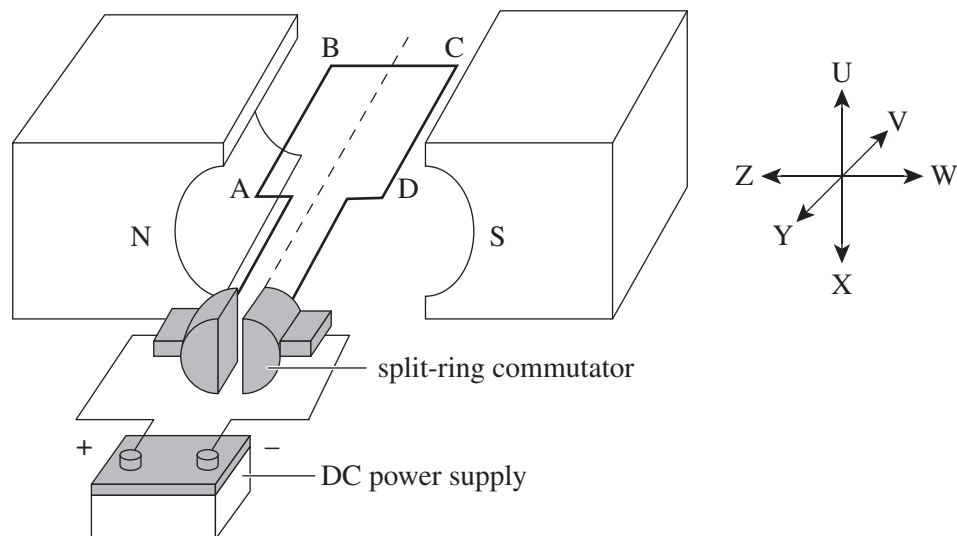

Figure 2

Data

battery voltage	6.0 V
number of loops in coil	20
resistance of coil	5.0 Ω
magnetic field strength	0.50 T
side lengths JK and ML	10 cm

a. Determine the size and direction (A–F) of the force acting on the side ML.

3 marks

N	Direction
---	-----------

- b. The motor is now modified such that the split-ring commutator is removed and the coil ends connect directly to the terminals of the battery, as shown in Figure 3.

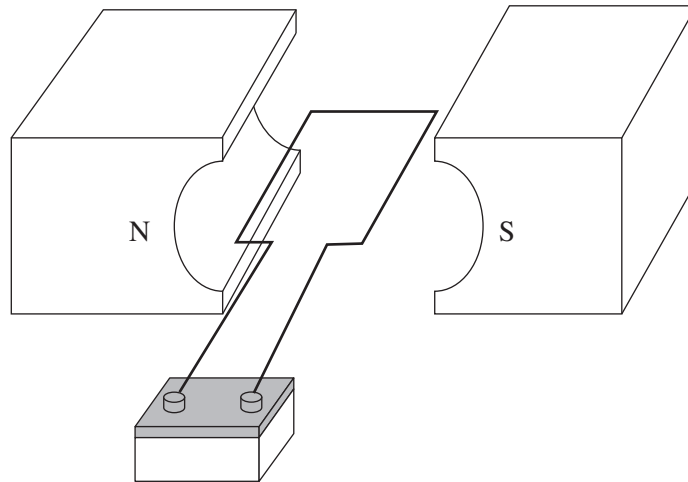

Figure 3

Explain the effect of this modification on the rotation of the coil.

2 marks

Question 3 (12 marks)

An experiment is undertaken where a magnet is dropped from rest through a ring, as shown in Figure 4.

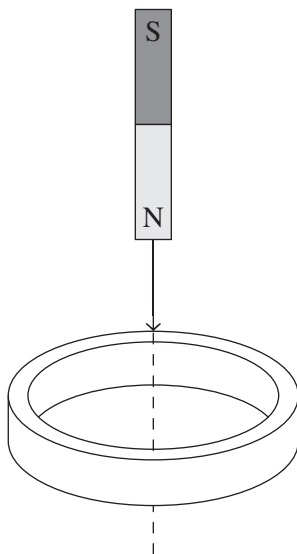

Figure 4

The diameter of the ring is 6.0 cm and the ring is made from solid iron. The magnetic field strength of the magnet is 0.10 T at the point where the end of the magnet just enters the plane of the ring.

- a.** Calculate the maximum magnetic flux experienced by the ring due to the magnet. 2 marks

Wb

The magnet is dropped from a rest position such that the north-pole end falls vertically downward from a distance of 30 cm to where it just enters the plane of the ring. At the position from where it is released, the ring experiences zero magnetic field due to the magnet.

- b.** Calculate the time it takes the magnet to fall the 30 cm distance. Air resistance is negligible. 2 marks

s

- c. Calculate the average EMF generated in the ring as it falls the 30 cm distance from rest to the point where the north pole just enters the plane of the ring. 2 marks

V

- d. Explain why a current is developed in the ring and how the direction of the current is determined as the magnet approaches the ring. Show the direction of the current on the reproduction of Figure 4 below. 4 marks

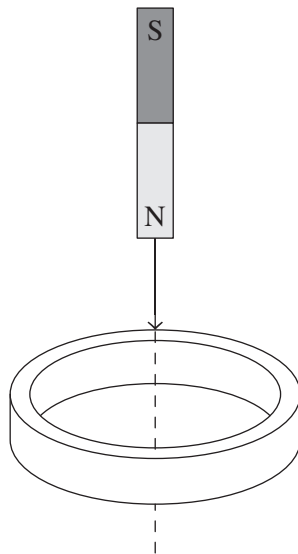

- e. Figure 5 shows the current in the ring versus the position of the magnet up to the point of entry of the north pole in the plane of the ring.

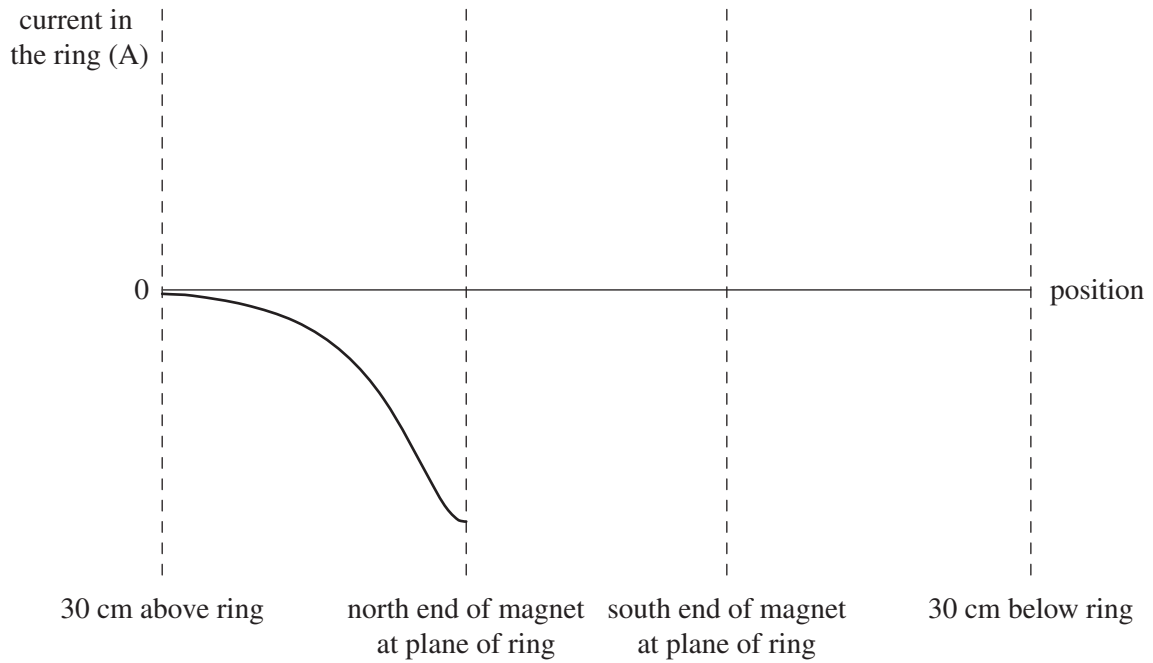

Figure 5

Complete Figure 5 by showing the current developed in the ring from the position of the north pole of the magnet 30 cm above the plane of the ring, to the position of the south pole of the magnet 30 cm below the plane of the ring.

2 marks

Question 4 (5 marks)

Figure 6 shows an electricity-generating station that generates 500 MW of power at $20.0 \text{ kV}_{\text{RMS}}$ input to the step-up transformer. This transformer has a turns ratio of $N_{\text{primary}} : N_{\text{secondary}} = 1 : 25$.

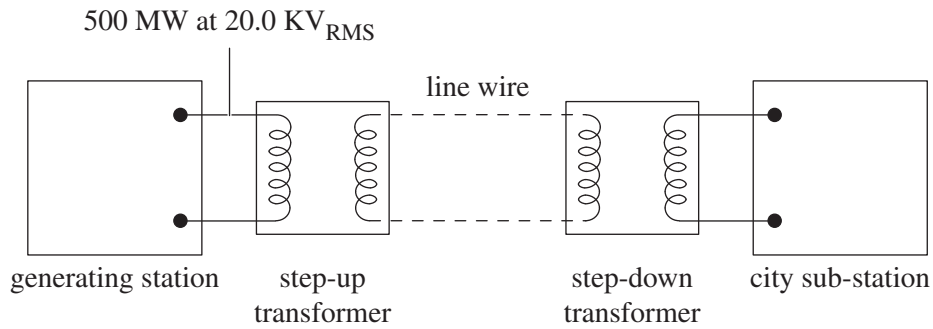
**Figure 6**

- a. Determine the peak current in the line wire. 3 marks

A

- b. Engineers test the power loss in the line wire (long-distance line) and find it to be 7.81 MW. Determine the resistance of the line wire. 2 marks

Ω

Question 5 (4 marks)

As part of a class experiment, students set up a netball ring assembly with a tennis ball launcher. The height of the ring above the plane of the tennis balls at launch is 2.40 m. The tennis balls are launched from a horizontal distance of 6.00 m from where the centre of the ring is vertically above the ground, and the launch angle with the horizontal is set to 40°. This is shown in Figure 7.

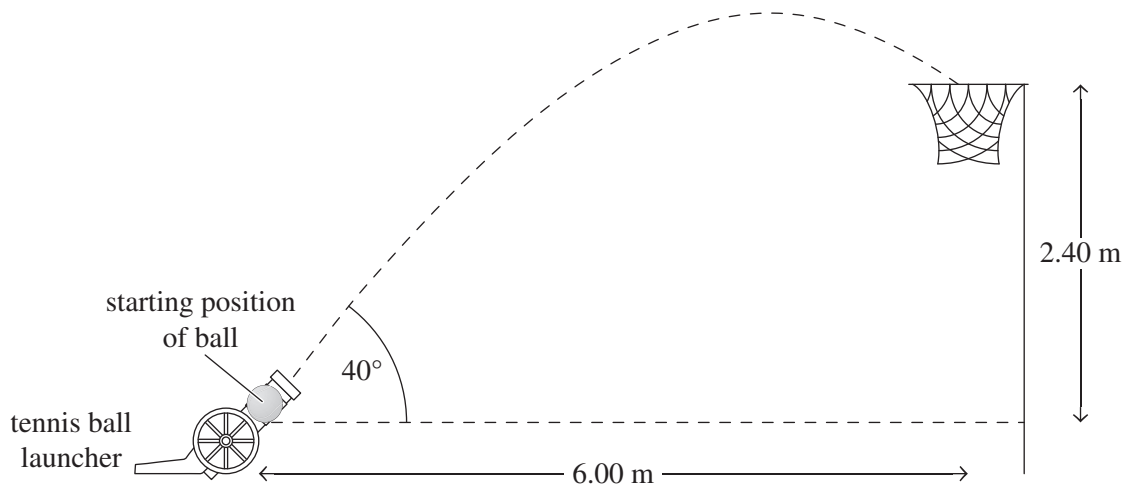

Figure 7

The students vary the launch speed as they trial each launch and find that a launch speed of 10.68 m s^{-1} enables tennis balls to pass through the ring.

- a. Determine the time it takes a ball to enter the plane of the ring from its launch point. Give your answer correct to three significant figures. 2 marks

s

- b. Using the data, show that the ball enters the plane of the ring when fired at 10.68 m s^{-1} . 2 marks

Question 6 (4 marks)

A motorcyclist rides around a corner on a horizontal road and leans into the corner to enable her to have a stable turn as she rides.

Two forces that act on her motorcycle as she turns the corner are the road reaction force, and the weight of the motorcycle and rider, as shown in Figure 8.

The angle of lean, θ , is the angle that the axis of the body of the rider leans from the vertical as the turn is negotiated.

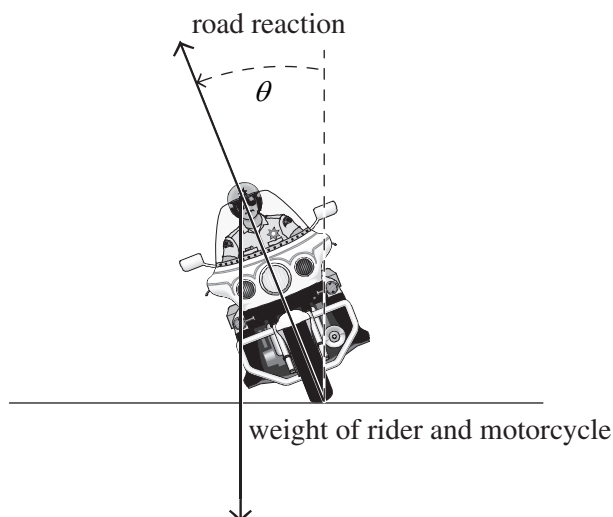
**Figure 8**

The road is a section of circle of radius 40.0 m and the angle of lean, θ , is 35° . The mass of the rider and motorcycle is 300 kg.

- a. Explain how the forces shown enable the rider to maintain her motorcycle in a stable path as she takes the turn. 2 marks

- b. Calculate the speed of the motorcycle as it makes the turn under the conditions described. 2 marks

m s^{-1}

Question 7 (5 marks)

A car is undertaking a loop-the-loop in a vertical circular track, as shown in Figure 9. The radius from the centre of the circle to the centre of mass of the car has a value of 6.0 m.

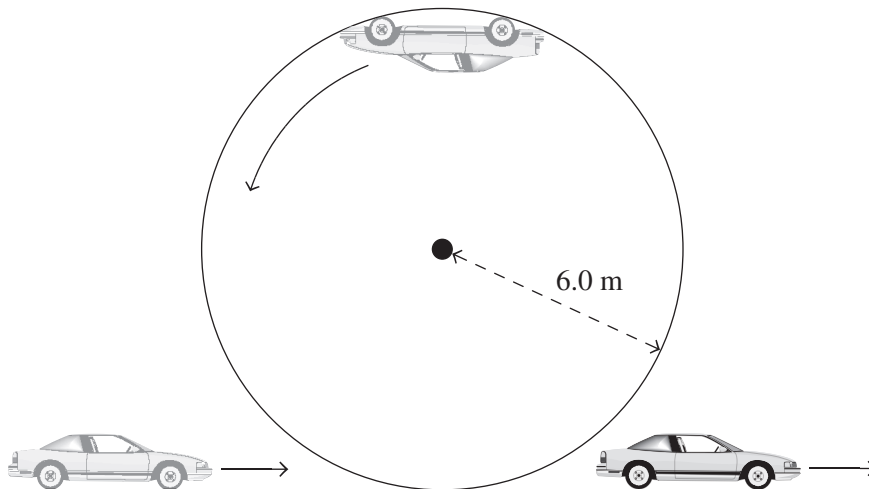

Figure 9

- a.** Calculate the speed of the car when it is at the top of the loop such that the driver feels a normal reaction equal to their weight. 3 marks

m s^{-1}

- b.** The car strikes a bump on its upwards rise and instead only travels at 8.5 m s^{-1} when it is at the very top of the track.
 Calculate the speed of the car at the very bottom of the track, assuming that the loop-the-loop track is frictionless and the engine force is not used as the car is steered from the top of the loop to the very bottom of the loop. 2 marks

m s^{-1}

Question 8 (6 marks)

Astronauts in two spacecraft, SU13 and MX5, want to conduct tests to determine if the considerations of special relativity are correct.

They organise for a 1000 m distance to be set up between two markers in space. The markers remain at this distance apart the entire duration of the tests.

The astronauts in SU13 remain stationary relative to the markers. The astronauts in MX5 travel at a constant speed of $0.90c$ relative to the markers. This is shown in Figure 10.

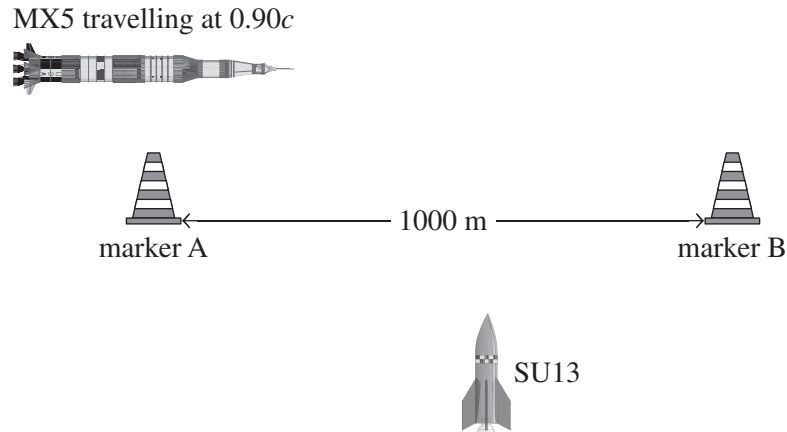
**Figure 10**

The astronauts in MX5 start their clock as soon as they see themselves go past marker A and stop their clock as soon as they see themselves go past marker B. Simultaneously, the astronauts in SU13 start their clock as they see MX5 at the position of marker A and then stop their clock as they see MX5 at the position of marker B.

The astronauts of SU13 measure the time for the event to be 3.704×10^{-6} s.

- a.** Determine the time taken for MX5 to travel the distance between the two markers as measured by the clock in MX5.

2 marks

s

Question 9 (8 marks)

The International Space Station (ISS) is in orbit around Earth.

Data

altitude of orbit of ISS	$4.05 \times 10^5 \text{ m}$
radius of Earth	$6.38 \times 10^6 \text{ m}$
Earth's gravitational field strength at position of ISS	8.67 N kg^{-1}
mass of ISS	$4.19 \times 10^5 \text{ kg}$

- a. Calculate the gravitational force of the ISS acting on Earth. 2 marks

N

- b. Calculate the period of the orbit of the ISS. 3 marks

s

- c. Three students are having a discussion about the placement of a second satellite in the same orbit as the ISS.

Harry claims that it would be more useful if a second satellite could travel faster in the same orbit so that it could gather more data about Earth, and believes that this should be possible.

Mel thinks that Harry’s claim would be correct only if the second satellite has a lower mass to enable it to travel faster, keeping the same kinetic energy and momentum as the ISS.

Dana believes that the second satellite will only maintain the same speed as the ISS in the same orbit.

Evaluate the opinions of the three students.

3 marks

Question 10 (4 marks)

A truck of mass 5000 kg travelling at 5.0 m s^{-1} to the right approaches and collides with a small car of mass 830 kg travelling at 2.0 m s^{-1} , also to the right.

As a result of the collision, the truck slows to a speed of 4.5 m s^{-1} , still to the right. This is shown in Figure 11.

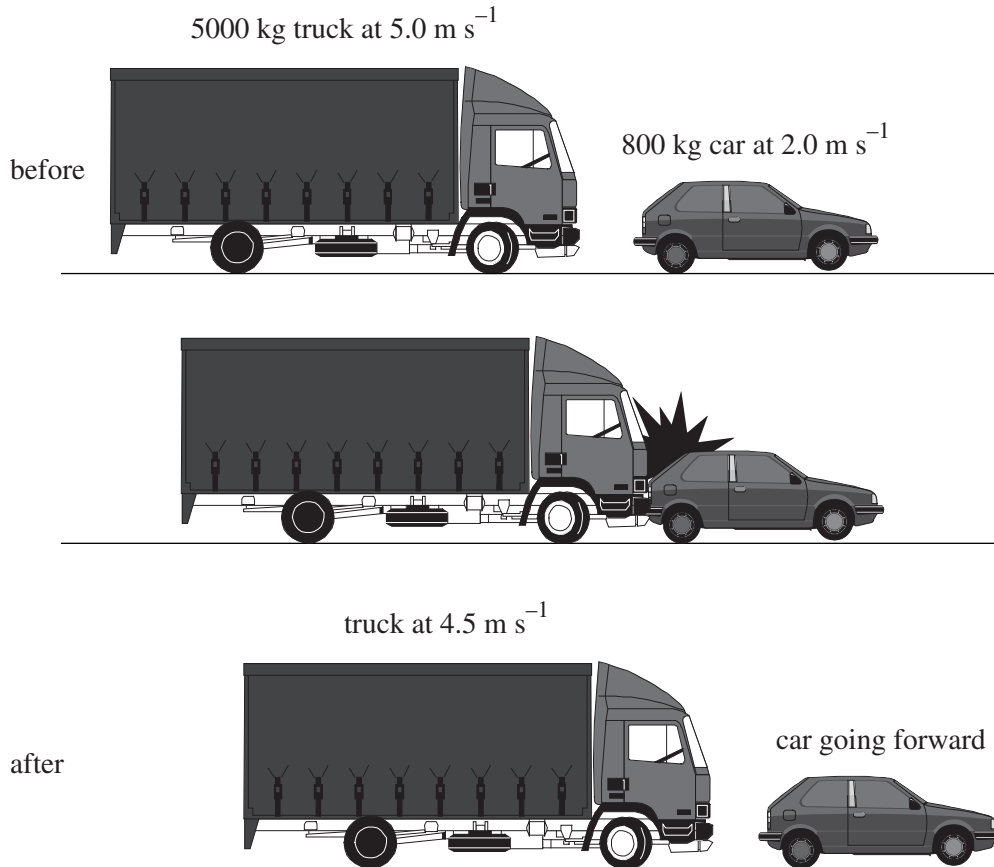
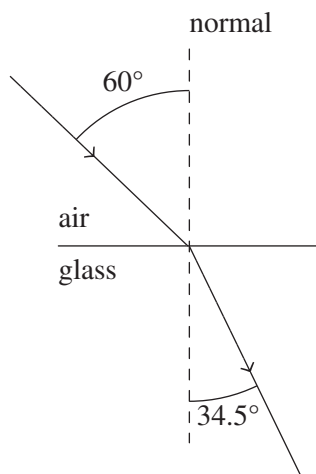

Figure 11

Determine whether the collision was elastic or inelastic and provide any calculations as evidence for your answer.

Question 11 (4 marks)

Light is passing from air into a glass prism, and the angle of incidence and angle of refraction are 60° and 34.5° respectively. This is shown in Figure 12. Assume that the speed of light in the air is the same as the speed of light in a vacuum.

**Figure 12**

- a. Determine the speed of light in the glass prism. 2 marks

m s^{-1}

- b. What is the largest angle of refraction that can be produced in the glass prism as light passes into it from air? 2 marks

°

Question 12 (13 marks)

Kim and Donald conduct an experiment to determine the relationship between the length of a pendulum and the time it takes to complete one oscillation. The experimental assembly is shown in Figure 13.

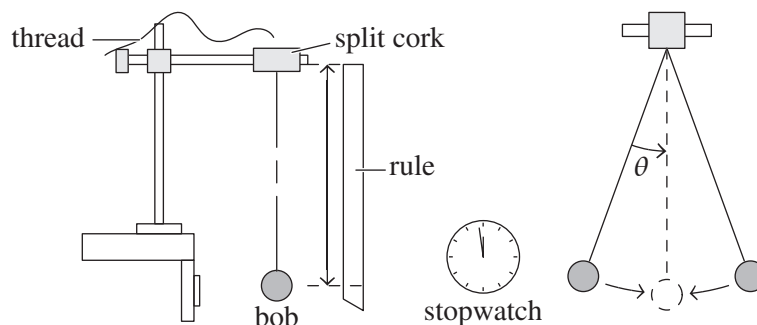
**Figure 13**

Kim and Donald establish the following hypothesis:

The relationship between the string length (from the cork to the centre of the bob) and the period (time for one oscillation) is expected to be a linear one.

They attain the following table of data and have made a note regarding the data acquisition.

String length (cm)	Time for ten oscillations (s)	It was decided to record the time of ten oscillations to increase the accuracy of the time measurements. The uncertainty in the string length is a constant ± 2 cm. The uncertainty in the time is a constant ± 0.50 s.
30	10.90	
50	14.30	
70	16.75	
90	19.10	
110	21.10	
130	22.94	

a. On the grid provided below:

- graph the raw data gathered by the students using the maximum area of the grid
- include scales and units on each axis
- insert appropriate uncertainty bars for both axes
- draw a smooth curve of best fit.

6 marks

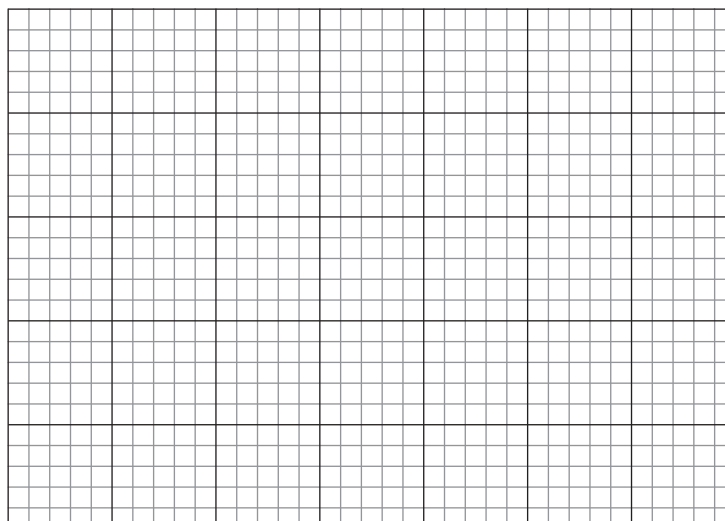

b. Complete the table by providing one variable from the experiment for each classification. 3 marks

Classification	Variable
controlled	
dependent	
independent	

c. Is the hypothesis stated by Kim and Donald correct or incorrect? Explain your answer. 2 marks

d. Having produced a graph of the data, Kim and Donald have two concerns:

1. whether the graph is valid as they did not plot the time for one oscillation, but rather the time for ten oscillations
2. whether their graph is valid as they plotted length in centimetres instead of metres

Discuss whether or not their concerns require the graph to be replotted to show the time of one oscillation and the length in metres in order to draw conclusions about any patterns. 2 marks

Question 13 (9 marks)

As part of a practical investigation, a group of Physics students are investigating sound as a wave phenomenon.

They set up a speaker that is 20 m from a wall in the school grounds. There are no other walls in the vicinity of the speaker. They use a signal generator to enable the speaker to emit sound in the direction of the wall, as shown in Figure 14.

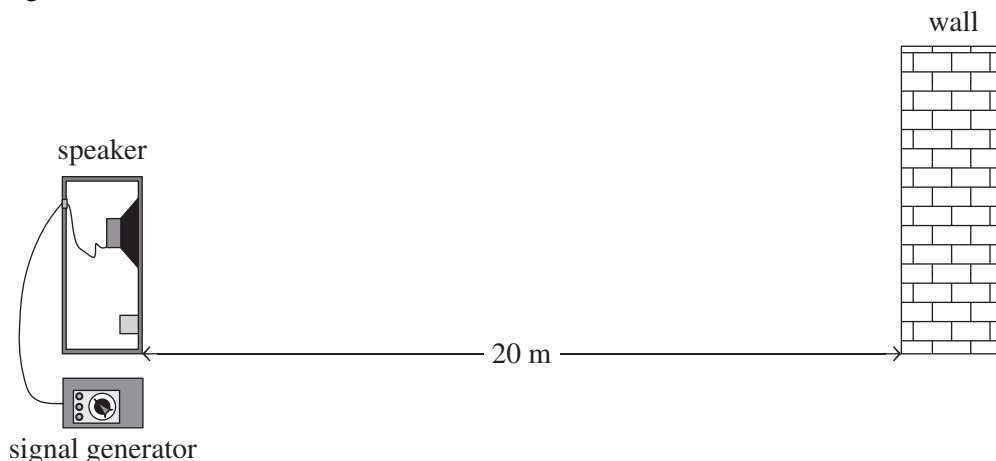
**Figure 14**

Phoebe, a student in the group, is going to walk from the speaker along the shortest path to the wall, as shown in Figure 15. The students set the signal generator to play a note of wavelength 5.0 m from the speaker.

**Figure 15**

Before Phoebe does so, the student group discusses what Phoebe is expected to hear as she walks from the speaker to the wall.

Samantha predicts that Phoebe will hear a constant intensity throughout her walk.

Harold predicts that Phoebe will hear a gradually increasing sound as she walks to the middle position, and then will hear a gradually decreasing sound as she walks from the middle position to the wall.

- a. Evaluate Samantha and Harold's predictions. 3 marks

Two identical speakers are set up so that they both face the same direction and are connected to the signal generator. Phoebe walks in the region in front of the speakers and experiences variations in sound intensity. She notices that at some positions she experiences high intensity in sound and at other positions she experiences low intensity in sound. At position X she experiences high sound intensity and at position Y she experiences low sound intensity. This is shown in Figure 16.

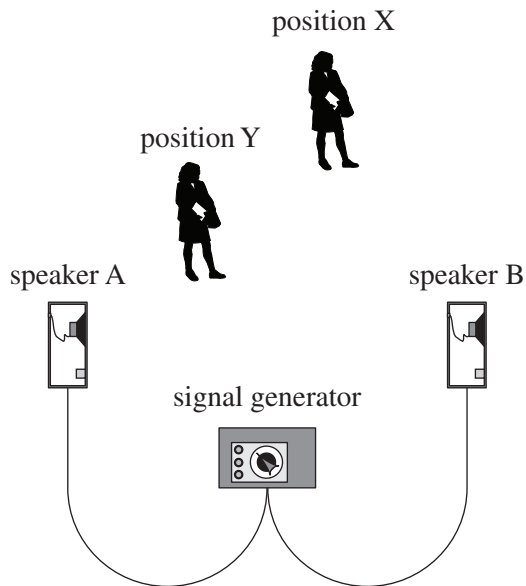

Figure 16

- b.** Explain why Phoebe’s experience of the sound at positions X and Y are different to each other. As part of your explanation, use the term ‘path difference’.

3 marks

- c. The measurements of distance from each of positions X and Y to each speaker are shown below.

distance from speaker A to position X	6.6 m
distance from speaker B to position X	5.0 m
distance from speaker A to position Y	2.3 m
distance from speaker B to position Y	5.1 m

Determine the smallest possible frequency that the signal generator is emitting through the speakers.

3 marks

Hz

Question 14 (9 marks)

In the photoelectric effect, monochromatic (single-coloured) light is shone onto a particular metal which forms the cathode of a vacuum tube, as shown in Figure 17.

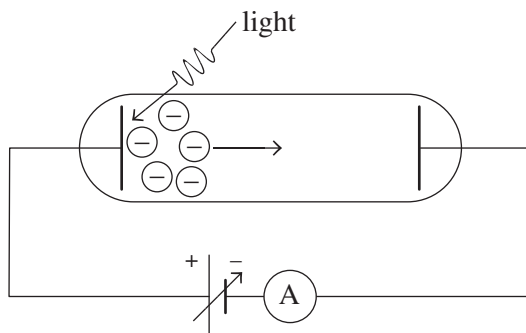

Figure 17

A graph of the maximum kinetic energy (eV) versus light frequency ($\text{Hz} \times 10^{14}$) for the experiment is shown in Figure 18.

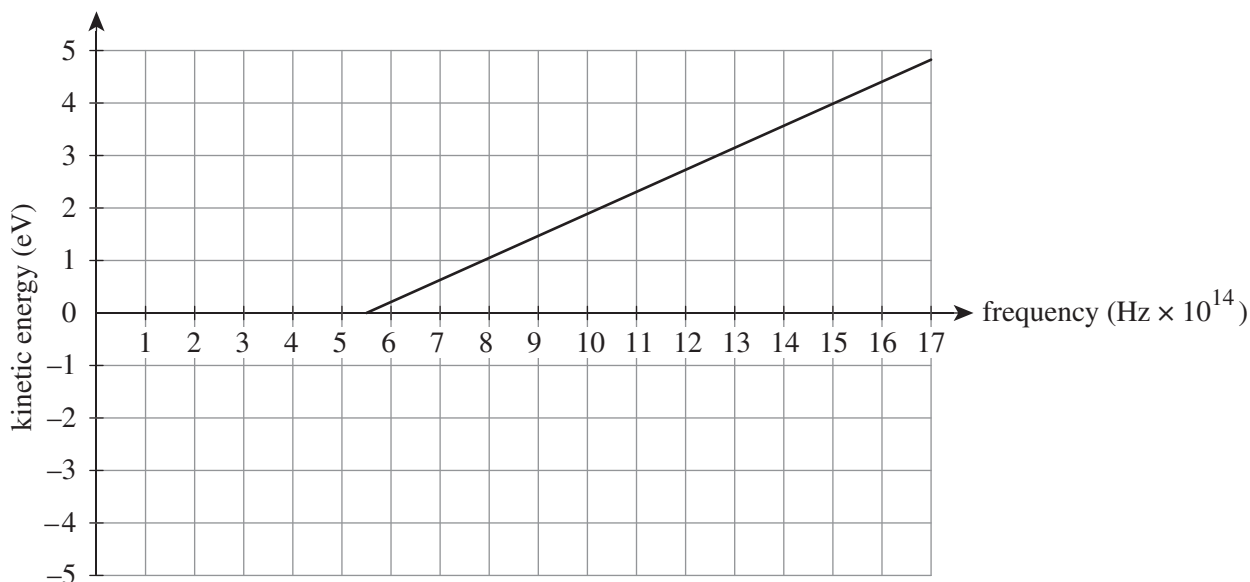

Figure 18

The experiment is then repeated, but with all colours of light at double the intensity of the light in the first experiment. The graph of the data for the second experiment is identical to that of Figure 18.

- a. Explain how the results for the two experiments represent any evidence contrary to the wave model in accounting for the photoelectric effect. 2 marks

- b.** If light of frequency 11×10^{14} Hz was used in the experiment, determine the stopping voltage attained. 2 marks

V

- c.** Green light has a wavelength of 545 nm.
 If red light is used in the experiment, explain the effect of this on emission of the photoelectrons. Provide calculations to support your answer. 3 marks

- d.** The metal in the cathode is replaced by a different metal such that when the experiment is conducted and light of frequency 12×10^{14} Hz irradiates it, photoelectrons of maximum kinetic energy 1 eV are emitted.
 Sketch the graph of maximum kinetic energy versus frequency for the new metal on Figure 18. 2 marks

Question 15 (5 marks)

Figure 19 shows an energy level diagram for a particular element.

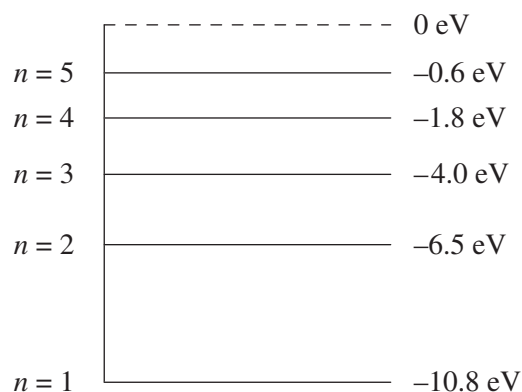

Figure 19

- a. Draw an arrow on the energy level diagram in Figure 19 showing the transition of an electron as it absorbs a photon of frequency 6.04×10^{14} Hz. Show all necessary workings. 2 marks

- b. Explain why an electron is able to exist at the energy level corresponding to -6.5 eV. 3 marks

Question 16 (9 marks)

An electron of mass 9.11×10^{-31} kg travels at 1% of the speed of light.

- a. Determine the de Broglie wavelength of the electron.

3 marks

nm

- b. Determine the potential difference used to accelerate the electron to this speed. Assume the electron's initial speed was close to zero.

2 marks

V

In an experiment, a beam of electrons of de Broglie wavelength 0.350 nm are fired at a very thin nickel (metal) target where the nickel atoms are 0.091 nm apart on average. The beam of electrons reflects from the target and onto a screen. The screen shows an image of the data in Figure 20, in which a series of bright and dark circular bands are seen.

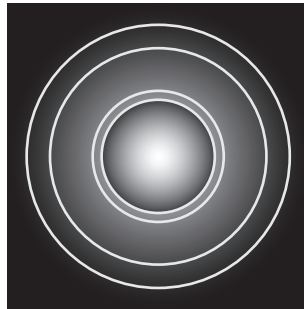

Figure 20

- c. What conclusion can be drawn from the data presented regarding the behaviour of the electrons?

2 marks

- d.** For your answer to **part c.**, provide an explanation for the behaviour of the electrons.
You may provide a calculation to assist your explanation.

2 marks

Question 17 (3 marks)

An experiment is conducted where individual electrons of the same kinetic energy are fired one at a time toward a screen with two slits, as shown in Figure 21.

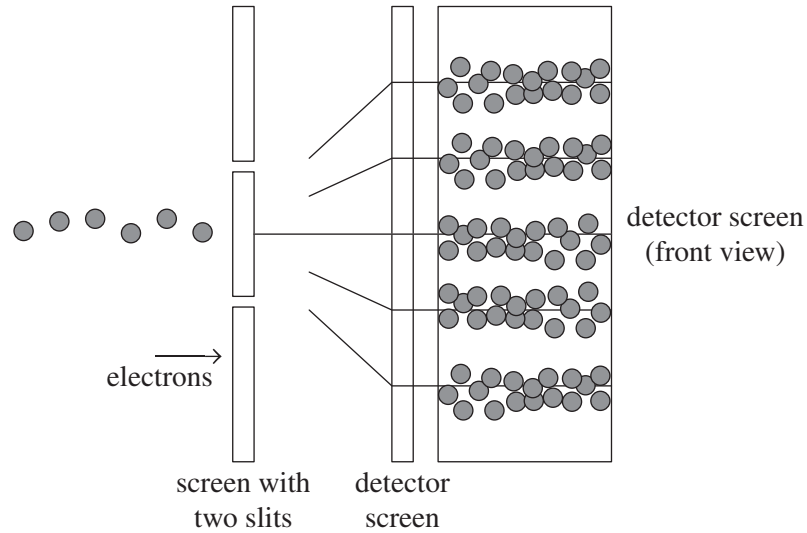

Figure 21

The electrons pass through the two-slit screen and strike a detector screen. The detector screen image shows that the electrons strike at particular positions. These positions are a regular spacing apart from each other.

Explain what the detector screen image in this experiment indicates about the nature of the electrons involved in the experiment.

END OF QUESTION AND ANSWER BOOKLET