

Year 12 Trial Exam Paper
2017
PHYSICS
Written examination

STUDENT NAME:

QUESTION AND ANSWER BOOK

Reading time: 15 minutes

Writing time: 2 hours 30 minutes

Structure of book

<i>Section</i>	<i>Number of questions</i>	<i>Number of questions to be answered</i>	<i>Number of marks</i>
A	20	20	20
B	18	18	110
			Total 130

- Students are permitted to bring the following items into the examination: pens, pencils, highlighters, erasers, sharpeners, rulers, pre-written notes (one folded A3 sheet or two A4 sheets bound together by tape) and one scientific calculator.
- Students are NOT permitted to bring sheets of blank paper or white out liquid/tape into the examination.

Materials provided

- Question and answer book of 39 pages
- An answer sheet for multiple-choice questions
- A formula sheet

Instructions

- Write your **name** in the box provided above, and on the answer sheet for multiple-choice questions.
- Unless otherwise indicated, the diagrams in this book are **not** drawn to scale.
- You must answer all questions in English.

Students are NOT permitted to bring mobile phones and/or any unauthorised electronic device into the examination.

This trial examination produced by Insight Publications is NOT an official VCAA paper for the 2017 Physics written examination.

The Publishers assume no legal liability for the opinions, ideas or statements contained in this trial exam.

This examination paper is licensed to be printed, photocopied or placed on the school intranet and used only within the confines of the purchasing school for examining their students. No trial examination or part thereof may be issued or passed on to any other party including other schools, practising or non-practising teachers, tutors, parents, websites or publishing agencies without the written consent of Insight Publications.

THIS PAGE IS BLANK

SECTION A – Multiple-choice questions

Instructions for Section A

Answer **all** questions in pencil on the answer sheet provided for multiple-choice questions.

Choose the response that is **correct** or that **best answers** the question.

A correct answer scores 1; an incorrect answer scores 0.

Marks will **not** be deducted for incorrect answers.

No marks will be given if more than one answer is completed for any question.

Unless otherwise indicated, the diagrams in this book are **not** drawn to scale.

Take the value of g to be 9.8 m s^{-2} .

Question 1

Which of the following diagrams best shows the magnetic field pattern between two south poles?

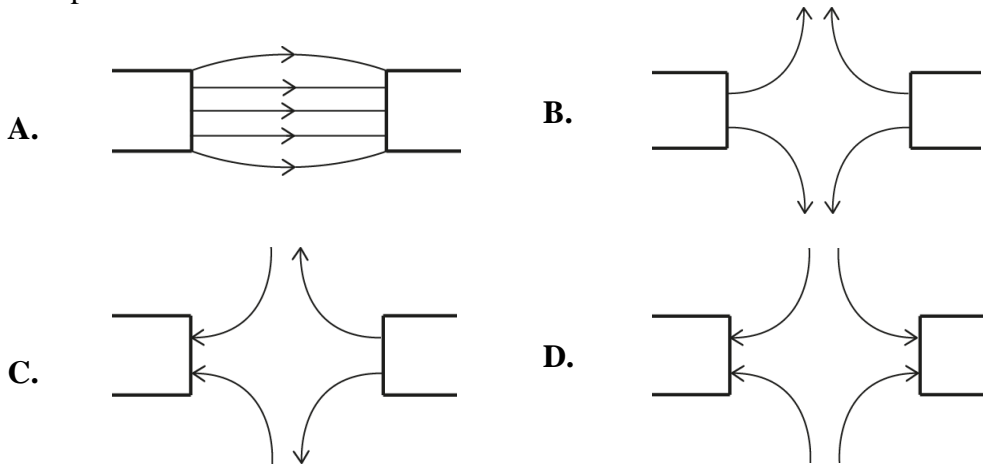

Question 2

A wire carrying a current into the page is placed in a magnetic field, as shown in the diagram below. Which of the following describes the direction of the force on the wire caused by the magnetic field?

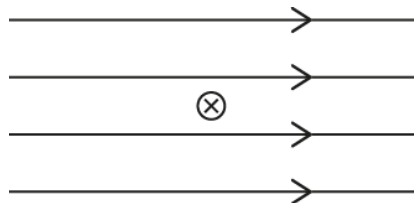

- A. up the page
- B. down the page
- C. left
- D. right

Question 3

Two small spheres hold electric charges of +0.01 mC and +0.03 mC and are placed 60 cm apart.

Which of the following best gives the magnitude and direction of the force on each? Use

$$k = 9.0 \times 10^9 \text{ N m}^2 \text{ C}^{-2}.$$

- A. 7.5 N repulsion
- B. 7.5 N attraction
- C. 7.5 MN repulsion
- D. 7.5 MN attraction

Question 4

An electron is accelerated between two plates through a potential difference of 5000 V.

How much kinetic energy does the electron gain from the electric field between these plates?

Ignore relativistic effects.

- A. $8.0 \times 10^{-16} \text{ J}$
- B. 5000 J
- C. $4.2 \times 10^7 \text{ J}$
- D. $1.7 \times 10^{15} \text{ J}$

Question 5

The three diagrams X, Y and Z below represent fields.

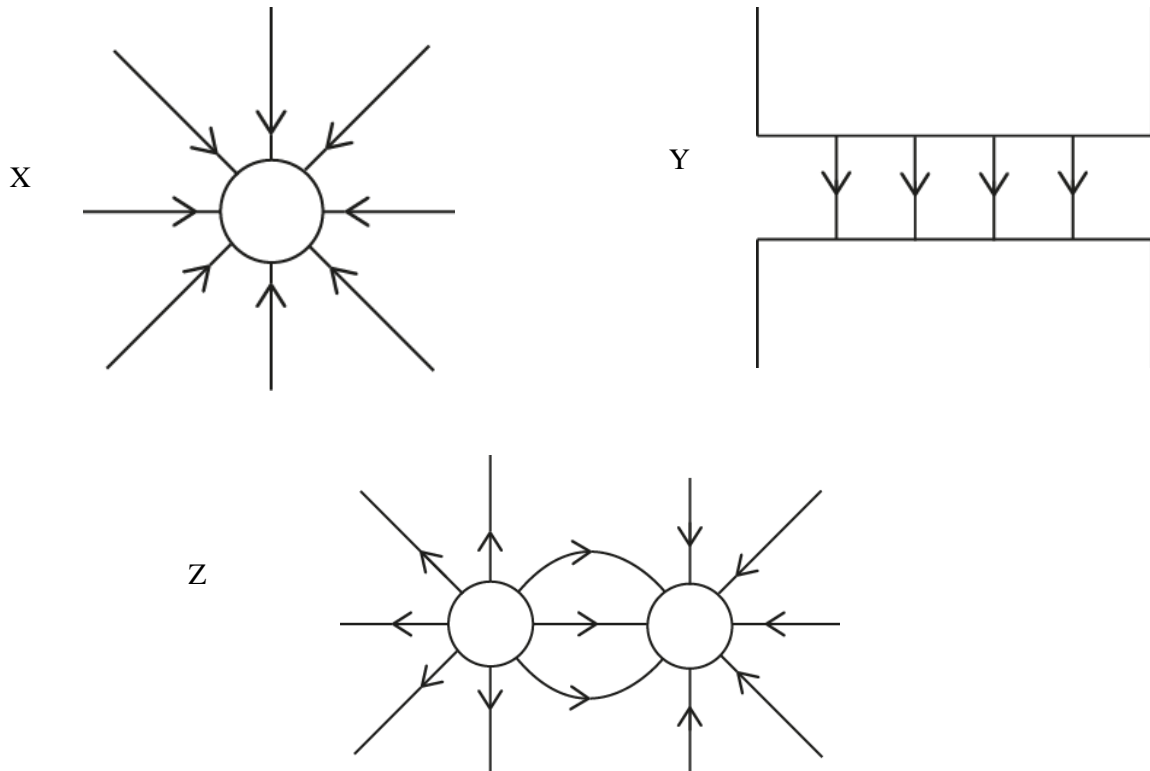

Which of the following correctly identifies the field types?

	X	Y	Z
A.	electric	magnetic	gravitational
B.	gravitational	electric	gravitational
C.	magnetic	gravitational	electric
D.	gravitational	magnetic	electric

Question 6

Some students measure a cart's mass as 12.1 ± 0.2 kg and its velocity as 3.0 ± 0.1 m s⁻¹. The uncertainty in their calculation of the cart's momentum ($p = mv$) is:

- A. $\pm 1.7\%$
- B. $\pm 3.3\%$
- C. $\pm 5.0\%$
- D. $\pm 6.7\%$

Use the following information to answer Questions 7 and 8.

Some students are investigating how temperature affects the spring constant, k , of various brands of elastic.

Question 7

Which of the following would be a discrete independent variable?

- A. the temperature of the elastic
- B. the brand of the elastic
- C. the extension of the elastic
- D. the spring constant, k , of the elastic

Question 8

Which of the following might the students choose to be a controlled variable?

- A. the brand of elastic
- B. the initial length of the elastic
- C. the temperature of the elastic
- D. the spring constant, k , of the elastic

Question 9

Some students are investigating the behaviour of a pendulum. Which of the following could potentially be a dependent variable?

- A. the mass of the weight at the end of the string
- B. the length of the string
- C. the angle of release
- D. the period of oscillation

Question 10

Which of the following correctly lists parts of the electromagnetic spectrum in order of **decreasing** energy?

- | | | | | |
|----|-------------|---------------|---------------|----------------|
| A. | microwaves | gamma rays | infrared | visible light |
| B. | gamma rays | infrared | visible light | AM radio waves |
| C. | X-rays | ultraviolet | visible light | FM radio waves |
| D. | ultraviolet | visible light | radio waves | gamma rays |

Question 11

An oscillating motor creates ripples in a water tank that are passed through a narrow gap, as shown in the diagram below.

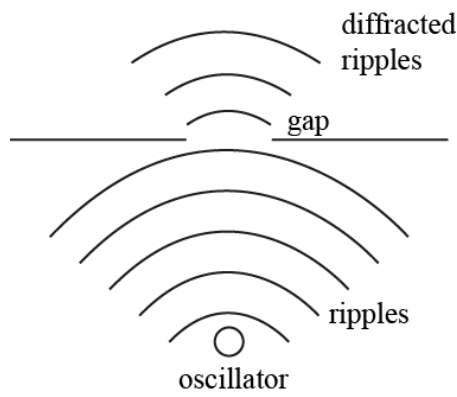

Which of the following will result in an increase in the diffraction of the ripples?

- A. a narrower gap
- B. a shorter wavelength
- C. moving the oscillator closer to the gap
- D. increasing the frequency of the oscillator

Question 12

Heisenberg's uncertainty principle states that as more is known about a particle's position

- A. less is known about its speed.
- B. less is known about its mass.
- C. less is known about its previous position.
- D. less is known about its future position.

Question 13

The diagram below depicts a water wave.

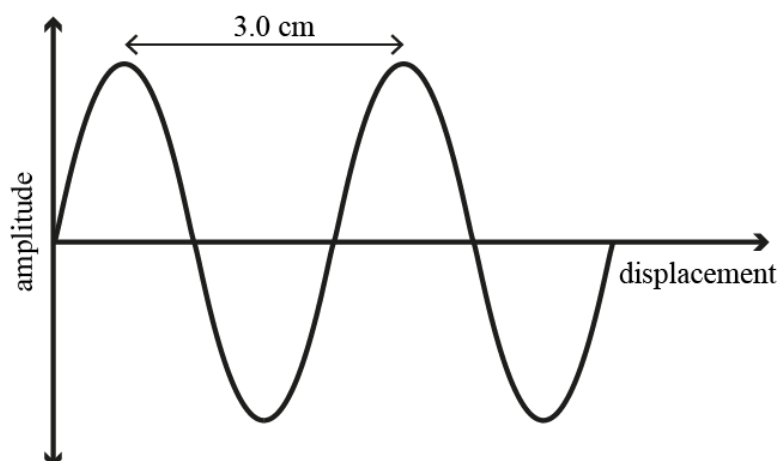

If the wave has a frequency of 300 Hz, which of the following best gives the speed of the wave?

- A. 900 m s⁻¹
- B. 90 m s⁻¹
- C. 9.0 m s⁻¹
- D. 0.9 m s⁻¹

Question 14

Which of the following best describes how the Doppler effect changes the sound waves from a racing car as it moves **away** from an observer?

- A. The velocity of the waves decreases.
- B. The wavelength of the waves decreases.
- C. The frequency of the waves decreases.
- D. The extent of diffraction of the waves decreases.

Question 15

A guitar string (fixed at both ends) is plucked and produces a fundamental frequency of 440 Hz.

Which of the following harmonics will also be present in the string?

- A. 110 Hz
- B. 220 Hz
- C. 660 Hz
- D. 880 Hz

Question 16

A spaceship, which has a length of 750 m when at rest, is travelling past a planet at $0.95c$ ($\gamma = 3.2$).

What is the length of the spaceship, as measured by a passenger on board?

- A. 234 m
- B. 750 m
- C. 1500 m
- D. 2400 m

Use the following information to answer Questions 17 and 18.

A pendulum is allowed to swing freely, as shown in the diagram below.

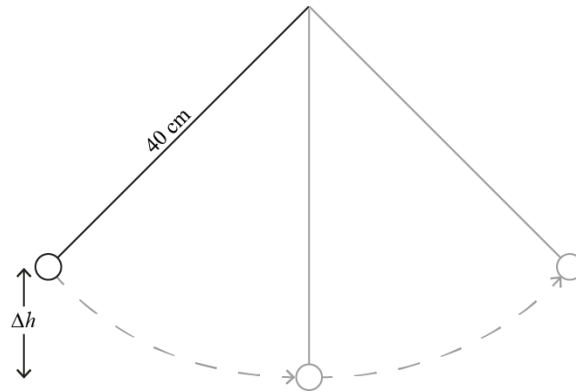

Question 17

Which of the following graphs best shows how kinetic energy (E_k) changes with height (Δh)? Take the bottom of the swing as $h = 0$ and ignore friction.

A.

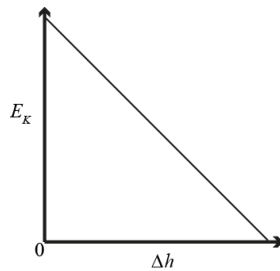

B.

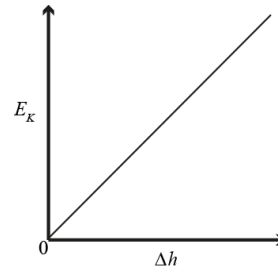

C.

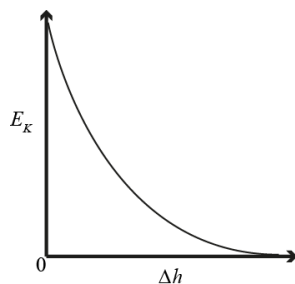

D.

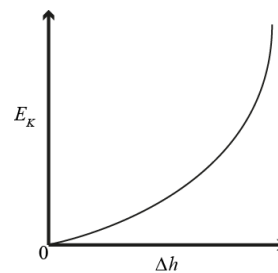

Question 18

At the bottom of its motion, the pendulum (mass 60 g) is found to be moving at 2.3 m s^{-1} . Which of the following best describes the tension in the string at this time?

- A. 0.6 N
- B. 1.4 N
- C. 2.0 N
- D. 2.6 N

Question 19

Which of the following best describes how light is produced in a synchrotron?

- A. Electrons are accelerated while moving at very high speeds.
- B. Protons are moved in a circular path by magnets.
- C. Electrons drop from a conduction band to a valence band.
- D. The random motion of electrons produces a broad spectrum of wavelengths.

Question 20

In experiments into the photoelectric effect, a 'stopping voltage' is commonly applied to the anode. This is done to

- A. amplify the photocurrent.
- B. give an indication of the maximum kinetic energy of the electrons.
- C. give an indication of the work function of the metal.
- D. give an indication of the intensity of the light.

SECTION B**Instructions for Section B**

Answer **all** questions in the spaces provided. Write using blue or black pen.

Where an answer box is provided, write your final answer in the box.

If an answer box has a unit printed in it, give your answer in that unit.

In questions where more than one mark is available, appropriate working **must** be shown.

Unless otherwise indicated, the diagrams in this book are **not** drawn to scale.

Take the value of g to be 9.8 m s^{-2} .

Question 1 (6 marks)

In 2015, the NASA probe *New Horizons* made the closest ever fly-by of the dwarf planet Pluto, coming within 12 500 km of Pluto's surface

Mass of probe	410 kg
Mass of Pluto	$1.3 \times 10^{22} \text{ kg}$
Radius of Pluto	1200 km
Gravitational constant, G	$6.67 \times 10^{-11} \text{ N m}^2 \text{ kg}^{-2}$

- a.** Calculate the strength of the gravitational attraction between Pluto and the *New Horizons* probe at an altitude of 12 500 km. Use the most appropriate number of significant figures in your answer.

3 marks

N

Figure 1 shows the gravitational field strength above the surface of Pluto.

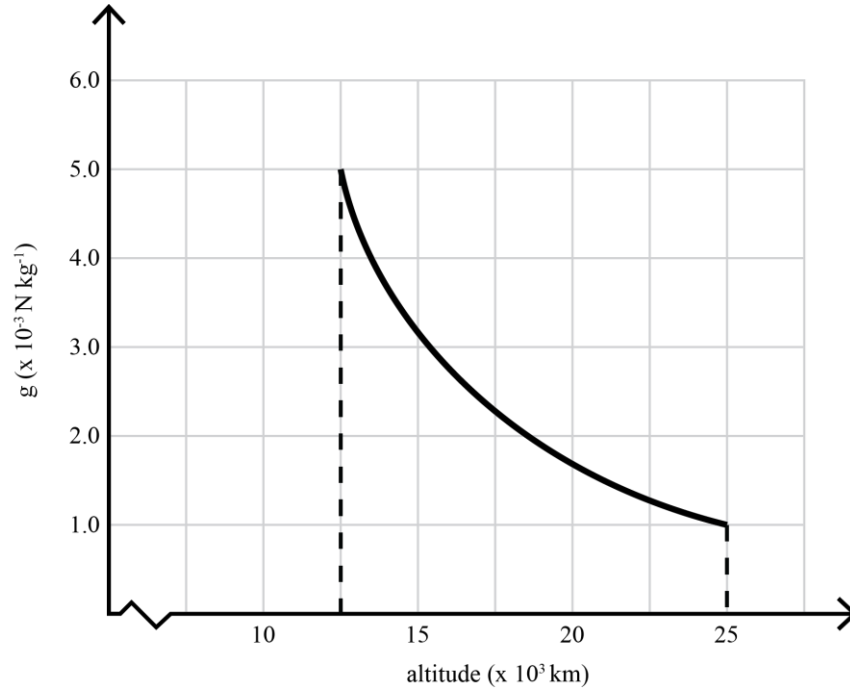

Figure 1

- b.** Use the graph in Figure 1 to calculate the kinetic energy gained by the probe as it moves from an altitude of 25 000 km to 12 500 km. Clearly show all of your working.

3 marks

J

Question 2 (3 marks)

Figure 2 shows a single point electric charge of $+2.0 \mu\text{C}$ at point *A*. At point *B* is a single point charge of $+e$.

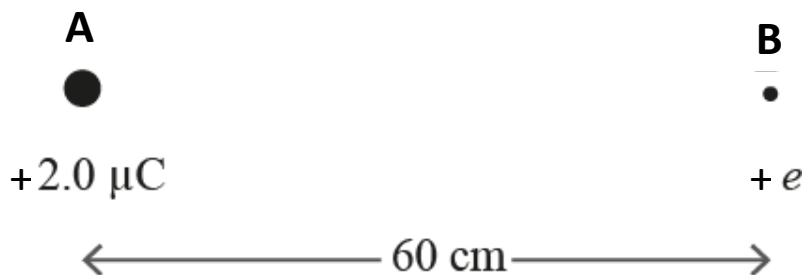
**Figure 2**

- a. Use an arrow to show the direction of the force on *B* due to *A*.

1 mark

- b. Calculate the strength of the electric field due to *A* at point *B*.

Use $k = 9.0 \times 10^9 \text{ N m}^2 \text{ C}^{-2}$.

2 marks

N C^{-1}

Question 3 (5 marks)

An electron moving at $1.5 \times 10^7 \text{ m s}^{-1}$ to the right passes through a magnetic field of strength 8.0 mT into the page, as shown in Figure 3.

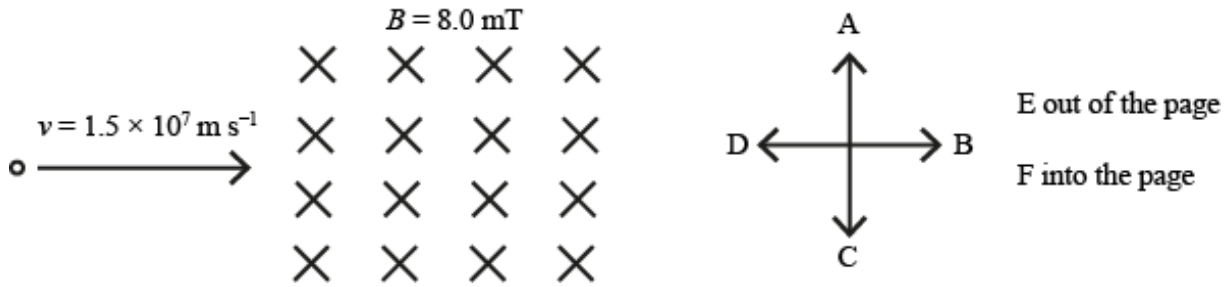
**Figure 3**

- a. Calculate the magnitude of the force that acts on the electron as it moves through the field.

2 marks

- b. Which of the options in Figure 3 (i.e. A–F) best shows the direction of the force on the electron as it enters the field?

1 mark

- c. Calculate the radius of the electron's path through the magnetic field.

2 marks

Question 4 (5 marks)

Figure 4 shows a DC motor consisting of multiple loops of wire in a uniform magnetic field.

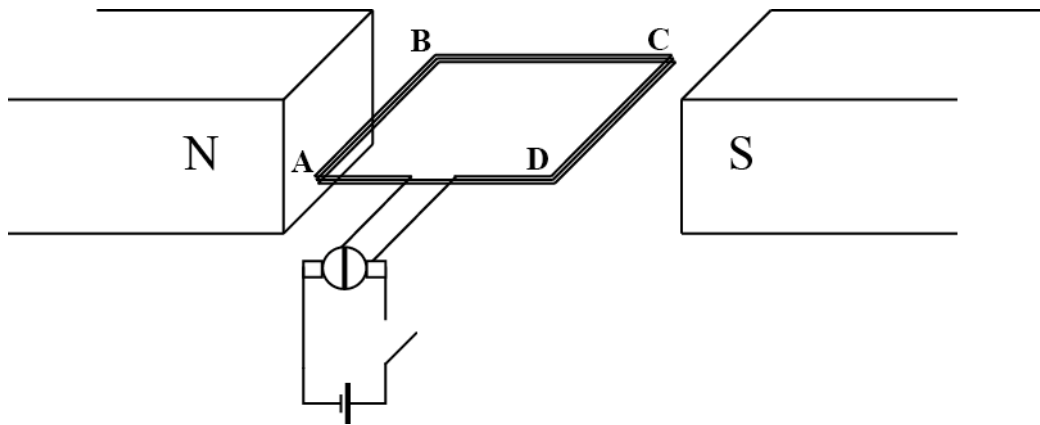

Figure 4

- a.** When the switch is closed, current flows through the loops of wire. Circle **one** of the options below to indicate in which direction the loops rotate and explain your answer.

Clockwise / Anticlockwise / No movement

3 marks

- b.** Describe what happens to the current in the loop as the coil rotates past the vertical position. Explain why this needs to occur.

2 marks

Question 5 (6 marks)

Figure 5 shows a generator consisting of 200 loops of wire in a uniform magnetic field of 6.0 mT. The area within the loops is 0.03 m².

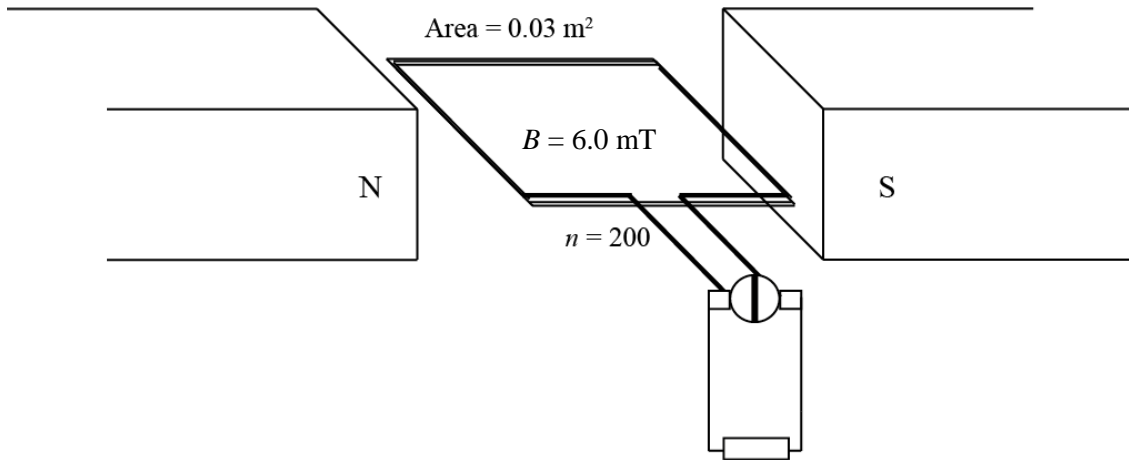
**Figure 5**

- a. Calculate the maximum flux that can pass through the loops. Include a unit with your answer.

2 marks

- b. The coil is rotated at a frequency of 20 Hz. Calculate the magnitude of the average EMF produced by the generator.

2 marks

- c. Another generator is rotated at 10 Hz and produces an average EMF of $3.5 \text{ V}_{\text{RMS}}$ through a set of slip rings. Sketch the output of this generator on the axes in Figure 6 below. Include a scale on the vertical axis.

2 marks

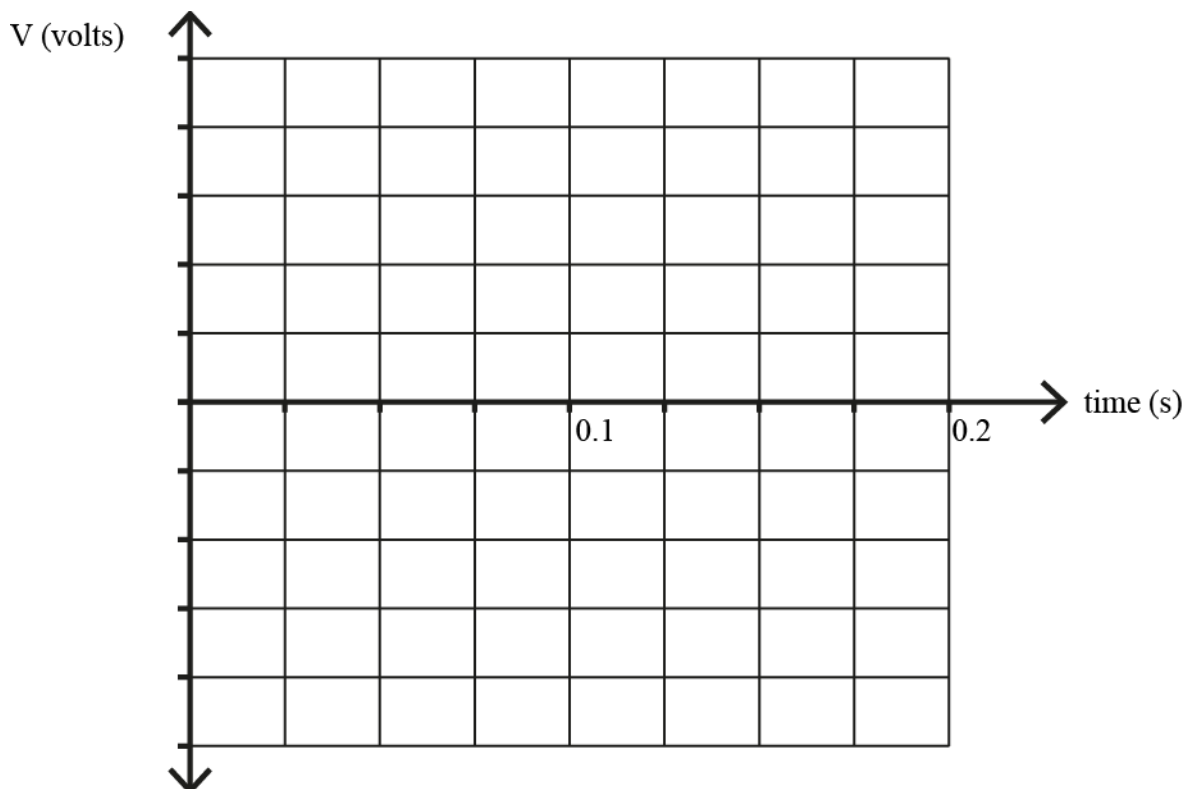
**Figure 6**

Question 6 (7 marks)

- a. A speaker plays a tone of 500 Hz. Calculate the wavelength of the sound wave produced. Take the speed of sound in air to be 340 m s^{-1} .

1 mark

m

- b. A second, identical speaker is placed beside the first and they both play the same tone with a wavelength of 0.760 m.

A student stands in front of the speakers, an equal distance from each speaker, as shown by location L in Figure 7. The student then walks in a straight line to location M . M is 3.80 m from speaker 1 and 1.14 m from speaker 2.

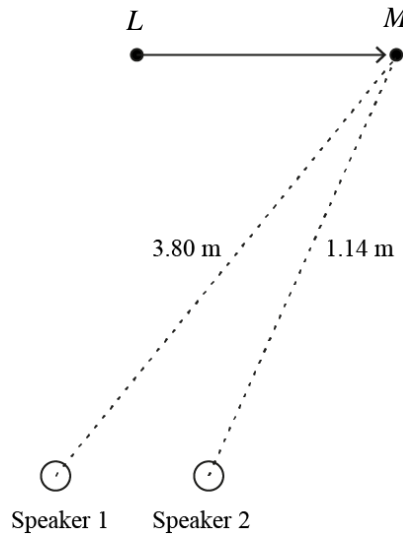
**Figure 7**

In the table below, describe how the student perceives the sound as they walk from location L to location M . Ignore echoes and reflected sound.

3 marks

	Perception of sound
At L	
From L to M	
At M	

- c. A single speaker now plays two tones together: one at 11 000 Hz and another at 1000 Hz. Two students, Ali and Bess, stand by the door to the room with the speaker, as shown in Figure 8.

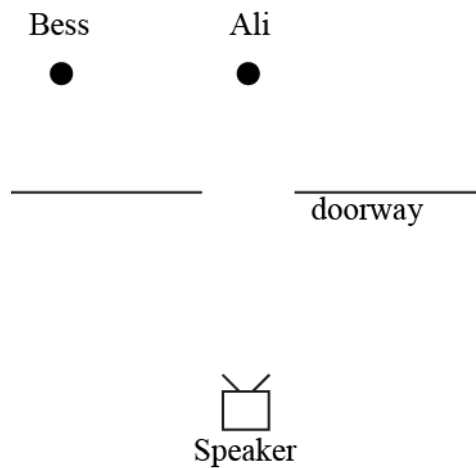

Figure 8

Ali hears both tones equally loudly.

Describe how Bess hears them. Use appropriate Physics principles to support your answer.

3 marks

Question 7 (6 marks)

A beam of light is shone from air into a piece of glass.

- a. On Figure 9 below, use the symbol θ_i to label the angle of incidence and θ_r to label the angle of refraction.

2 marks

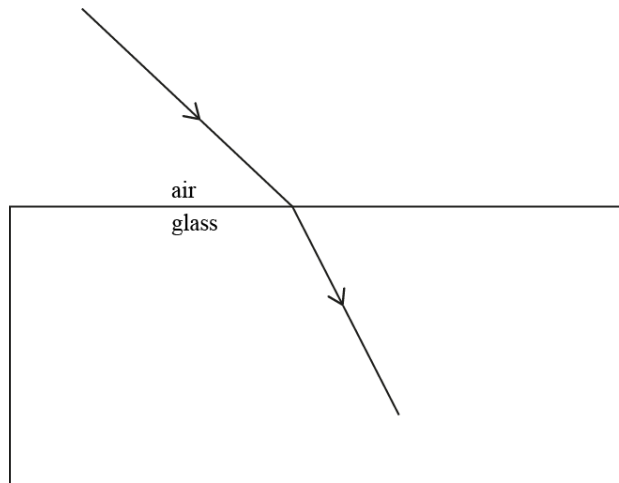
**Figure 9**

- b. If $\theta_i = 38.7^\circ$ and $\theta_r = 23.8^\circ$, calculate the refractive index of the glass.

Assume $n = 1.00$ for air.

2 marks

- c. Calculate the critical angle for total internal reflection at this interface. Identify whether this would occur from air into glass or from glass into air.

Air into glass / Glass into air (circle one)

2 marks

Question 8 (2 marks)

Students investigating light waves pass sunlight through two polarisation filters, whereby the second is oriented at 90° to the first, as shown in Figure 10.

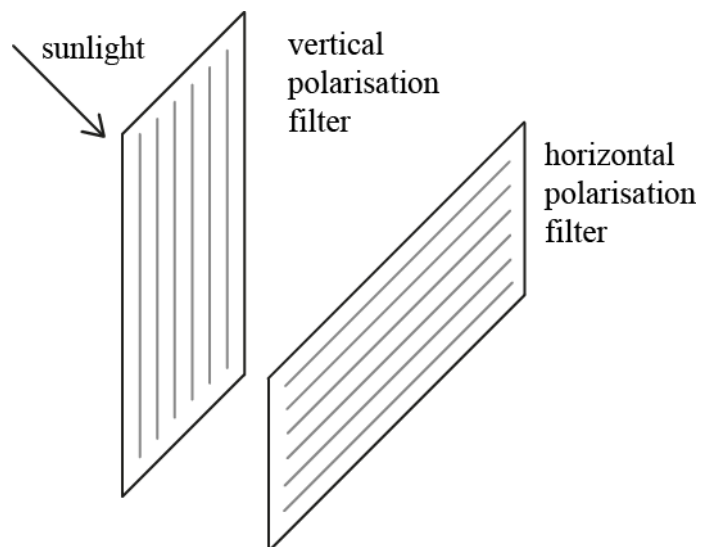
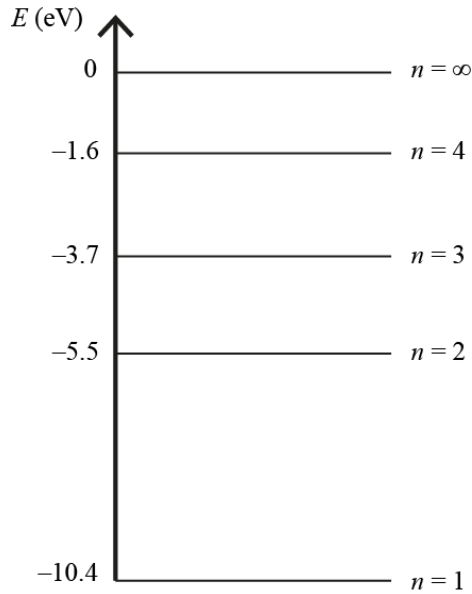

Figure 10

Briefly explain what the students observe as the light passes through the second filter and what the results of this experiment suggest about light waves.

Question 9 (6 marks)

Figure 11 shows the partial energy level diagram for mercury.

**Figure 11**

- a.** Calculate the energy of a photon with a frequency of 9.42×10^{14} Hz and draw a single arrow on Figure 11 to show how this photon could be emitted from a mercury atom.

3 marks

eV

- b.** Niels Bohr used the evidence from emission spectra experiments to devise a ‘quantised’ model of the atom. Louis De Broglie refined this model and was able to explain why no electron could exist between energy levels.

Outline how De Broglie improved upon Bohr’s model of the atom.

3 marks

Question 10 (6 marks)

A small house is powered by a generator that produces $250 \text{ V}_{\text{RMS}}$ through transmission lines with a total resistance of $6.0 \, \Omega$, as shown in Figure 12. With just the lights and the TV switched on, the house draws 5.0 A and appliances operate normally.

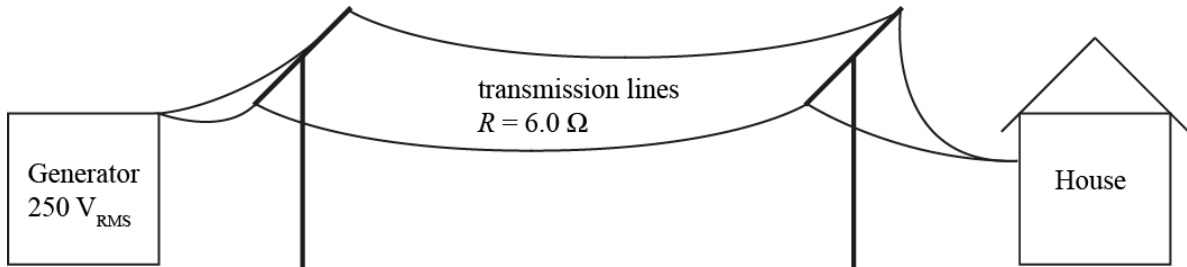

Figure 12

- a. When the residents turn on their electric kettle and microwave, the house draws 10.0 A . What voltage is provided to the house under these circumstances?

2 marks

	V
--	---

A 1 : 5 step-up transformer is installed at the generator and a 5 : 1 step-down transformer is installed at the house, as shown in Figure 13.

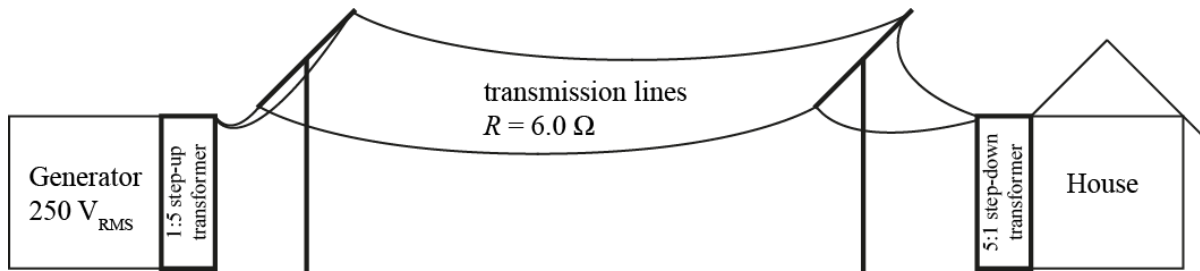

Figure 13

- b. When the house draws 10.0 A, how much current flows in the transmission lines?

1 mark

A

- c. 2500 W of power is produced by the generator. What percentage of the power is lost in the transmission lines when the house draws 10.0 A?

3 marks

%

Question 11 (8 marks)

In crash testing, a 200 kg block is dropped and allowed to swing into an 85 kg crash test dummy, as shown in Figure 14.

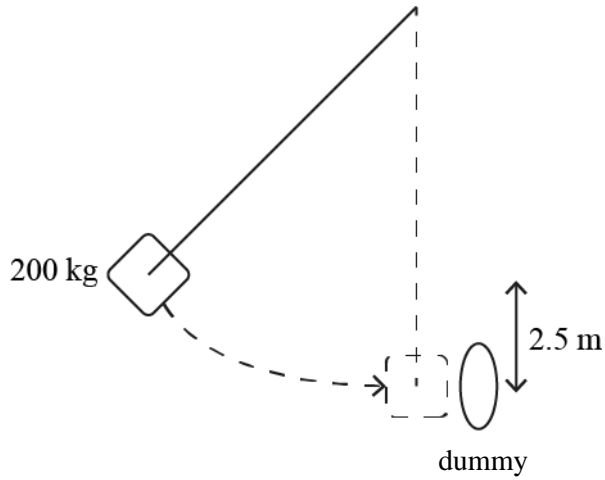

Figure 14

- a.** If the block falls 2.5 m, how much kinetic energy is delivered to the dummy?

2 marks

	J
--	---

- b.** In another crash test, the 200 kg block is dropped from 7.2 m and hits the dummy at 20 m s^{-1} . After the collision, the block and the dummy move off together.

Calculate their velocity immediately after the collision.

2 marks

	m s^{-1}
--	-------------------

- c. Show that this collision is inelastic.

2 marks

- d. In another crash test, the 200 kg block is used to break a piece of wood, as shown in Figure 15.

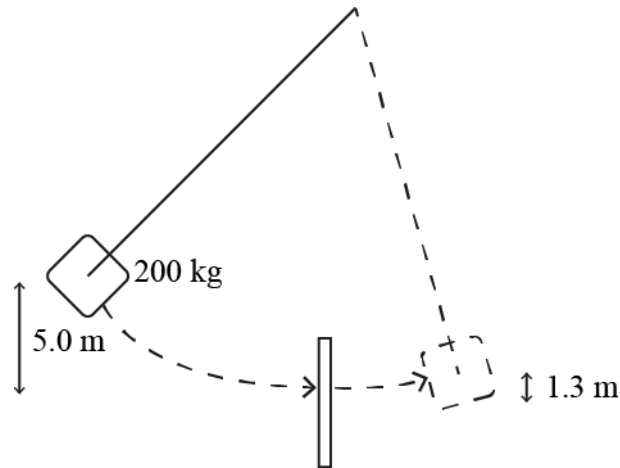

Figure 15

If the block is dropped from 5.0 m, breaks the piece of wood and continues to a height of 1.3 m, how much energy was used to break the wood?

2 marks

J

Question 12 (3 marks)

A 63 g tennis ball is attached to a light string and swung in a circle, as shown in Figure 16.

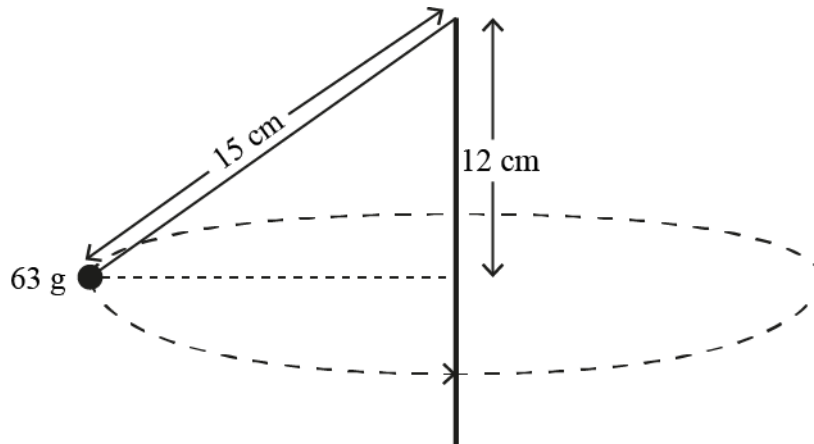

Figure 16

Use the information in the diagram above to calculate the net force acting on the ball. Clearly show each step of your working.

N

Question 13 (5 marks)

David stands at the edge of a 6.0 m tall building and wants to kick his soccer ball onto the roof of the building across the road, as shown in Figure 17.

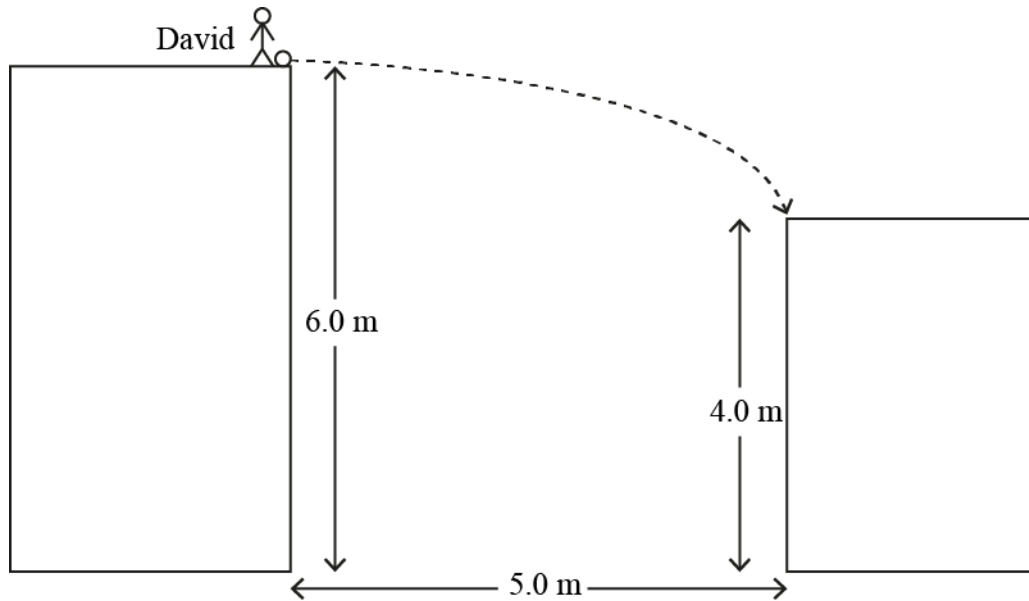
**Figure 17**

- a. If the ball is kicked horizontally, what is the minimum initial velocity required to land the ball on the opposite roof?

3 marks

m s^{-1}

As shown in Figure 18, David leans over the edge of his building and throws the ball straight up at 4.9 m s^{-1} .

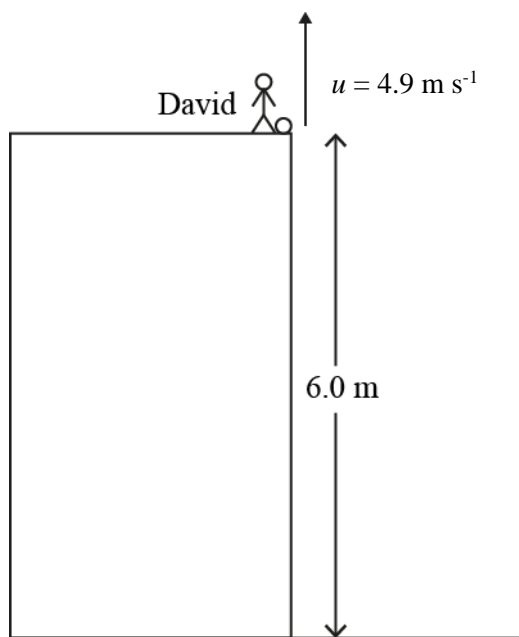

Figure 18

- b.** How fast is the ball moving when it hits the ground?

2 marks

m s^{-1}

Question 14 (8 marks)

Some students are investigating a step-down transformer, attempting to find the ratio of turns in the primary coil to the secondary coil.

The students apply a voltage to the primary coil, which is measured with a digital multimeter (± 0.005 V). Uncertainty in the primary coil measurements may be ignored. The students use an analogue voltmeter marked in 1 V increments to record the voltage across a load resistor connected to the secondary coil. Their data is shown in the table below.

Primary coil (volts)	Secondary coil (volts)
0.10	1.8
0.20	4.3
0.30	5.9
0.40	7.7
0.50	10.1

- a. Using the grid below, record the data from the table onto a graph. Include realistic uncertainty (error) bars, labels, scales and units. Draw a line of best fit.

5 marks

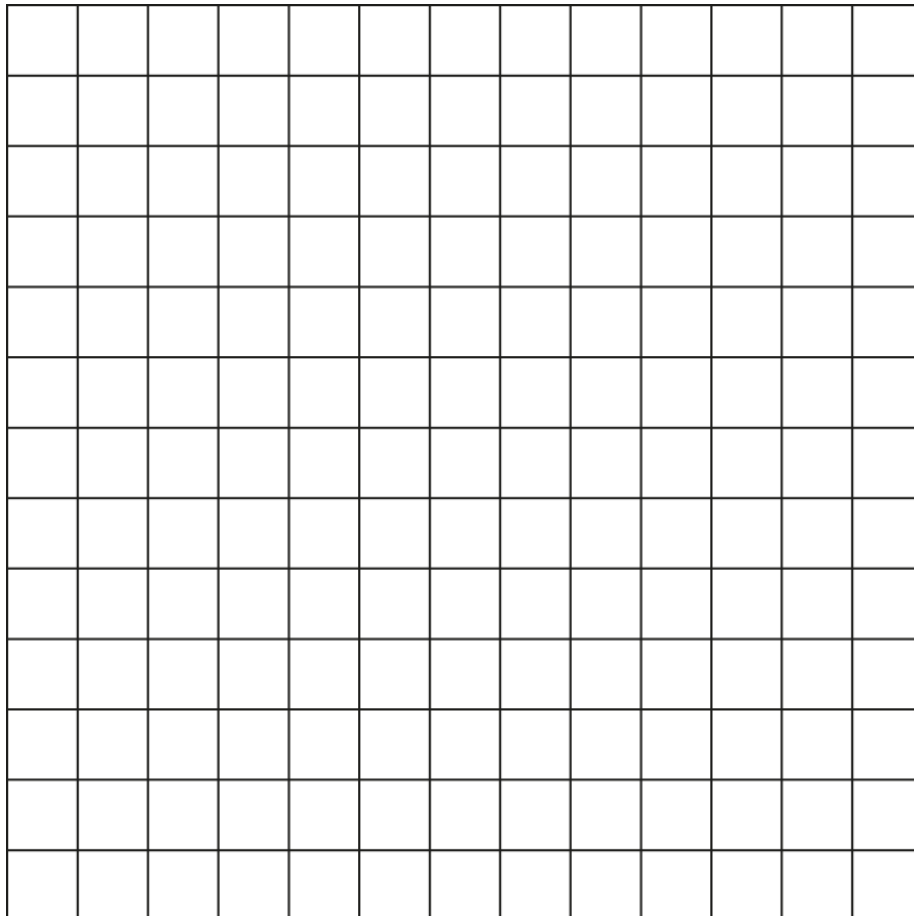

- b.** Use the error bars on the graph to calculate the highest and lowest possible values for the ratio $\frac{\text{secondary coil voltage}}{\text{primary coil voltage}}$.

3 marks

Highest possible value:

Lowest possible value:

Question 15 (10 marks)

In a particular thought experiment, Chris is on board a moving train travelling at $0.98c$ relative to Deb, as shown in Figure 19.

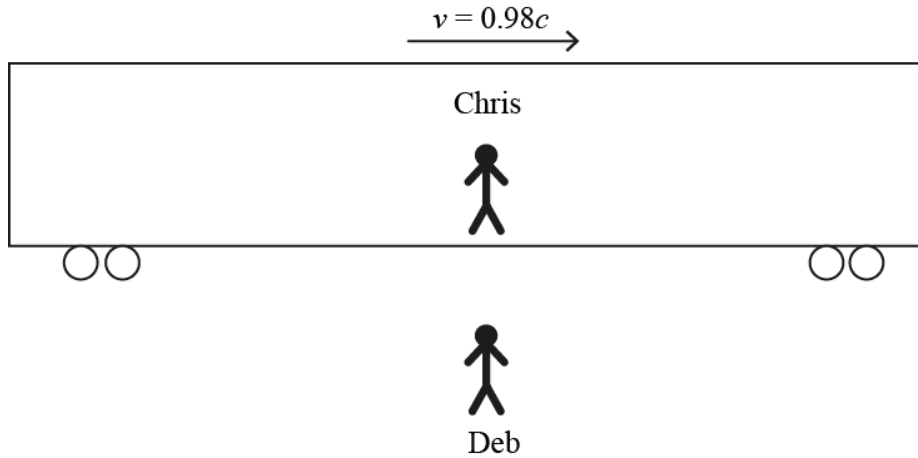
**Figure 19**

- a. Chris measures the train to be 10 m long. How long does it appear to Deb?

2 marks

m

Some time later, the train is travelling at a constant velocity of $2.97 \times 10^8 \text{ m s}^{-1}$. Chris sees Deb drop a ball. From Chris's perspective it takes 4.0 s to reach the ground.

- b. How long does Deb see it take for the ball to reach the ground?

2 marks

s

- c. Both Chris and Deb are convinced that they are at absolute rest because no net force acts upon them.

Chris claims that he is at rest relative to the Universe because he is in an inertial frame of reference.

Deb claims that she is at rest relative to the Universe because she is not moving.

Who is correct? Choose one option below and explain your answer by referring to Einstein's first postulate.

Chris / Deb / Both / Neither

3 marks

- d. When four hydrogen nuclei are combined into one helium nucleus in the Sun, 25 MeV of energy are released. Calculate how much mass is lost when this happens and identify how many protons or neutrons (if any) are destroyed in this process.

3 marks

Question 16 (8 marks)

- a.** Electrons are accelerated from rest by an electron gun at 15.0 V. Show that the De Broglie wavelength of these electrons is 3.2×10^{-10} m. Relativistic effects can be ignored.

3 marks

- b.** What frequency of electromagnetic radiation would be required to produce an identical diffraction pattern to the electrons described in **part a.**?

2 marks

Hz

- c.** A flea (200 μg) can jump at 2.0 m s^{-1} . How many violet photons ($\lambda = 400 \text{ nm}$) would it take to have the same momentum as a jumping flea?

3 marks

--

Question 17 (10 marks)

The photoelectric effect involves shining particular frequencies of light at varying intensities onto a metal plate and measuring the rate and the kinetic energy of the ejected electrons. Experiments such as these were used by Einstein and others to support the particle model of light.

- a. Outline the results of the photoelectric effect experiments that would be expected under the **wave model** of light.

3 marks

- b. Einstein and Newton disagree about the nature of space and time. Compare what each scientist concluded about each of these concepts. Refer to at least one piece of experimental evidence that supports Einstein’s claim.

4 marks

- c. Kinetic energy is calculated differently using classical physics compared with special relativity. Use the example of a 10.0 kg asteroid moving towards Earth at 0.70 times the speed of light ($\gamma = 1.40$) to show how the two systems calculate kinetic energy differently. Identify which would be the most appropriate calculation to use in this circumstance.

3 marks

Question 18 (6 marks)

In one photoelectric effect experiment, ultraviolet light at a frequency of 8.0×10^{14} Hz is incident on a sample of lithium metal (work function = 2.9 eV).

A stopping voltage of 0.45 V is recorded.

- a. Calculate the threshold frequency for this metal.

2 marks

Hz

Another metal is tested and the results are shown on the graph in Figure 20.

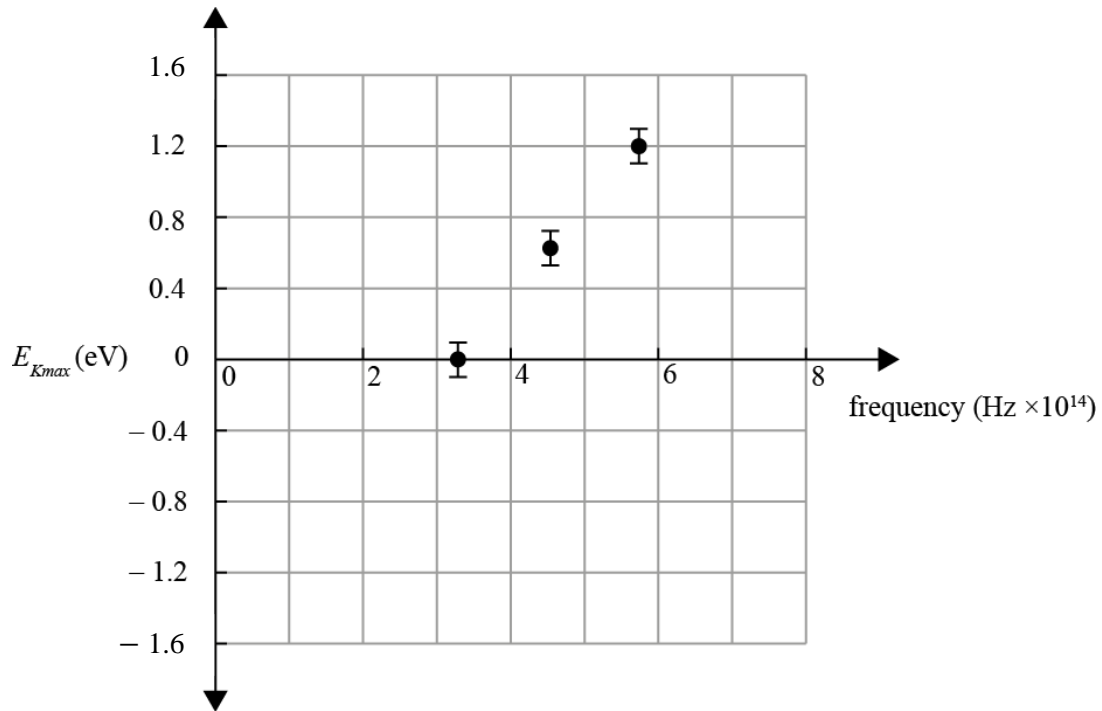

Figure 20

- b.** Use the graph above to calculate the value of Planck's constant. Clearly show on the graph how you reached your answer.

3 marks

eV s

- c.** Use the graph in Figure 20 to calculate the stopping voltage that would be recorded when light of 5.0×10^{14} Hz is incident on this metal. Clearly show on the graph how you reached your answer.

1 mark

END OF QUESTION AND ANSWER BOOK