



## *Units 3 and 4 Physics*

### *Practice Exam Question and Answer Booklet*

Duration: 15 minutes reading time, 2 hours 30 minutes writing time

Structure of book:

Section	Number of questions	Number of questions to be answered	Number of marks
A Part 1	16	16	40
A Part 2	7	7	20
A Part 3	18	18	42
A Part 4	12	12	26
B	66	11	22
Total			150

- Students are permitted to bring into the examination room: pens, pencils, highlighters, erasers, sharpeners, rulers, up to two pages (one A4 sheet) of pre-written notes (typed or handwritten) and one scientific calculator.
- Students are not permitted to bring into the examination room: blank sheets of paper and/or white out liquid/tape.

Materials supplied:

- This question and answer booklet of 56 pages, including a formula sheet on the last three pages.

Instructions:

- You must complete all sections of the examination.
- Write all your answers in the spaces provided in this booklet.

## Section A – Core

### Instructions

Answer all questions for all areas of study in this section in the spaces provided.

Where an answer box has a unit printed in it, give your answer in that unit.

You should take the value of  $g$  to be  $10 \text{ m s}^{-2}$ .

In questions where more than one mark is available, appropriate working must be shown.

### Part 1: Motion in one and two dimensions

The following information relates to questions 1 to 3:

A 100 g yo-yo attached to a string of length 30 cm is swung so that it moves in a horizontal circle. The period of the ball's motion is 1.2 seconds.

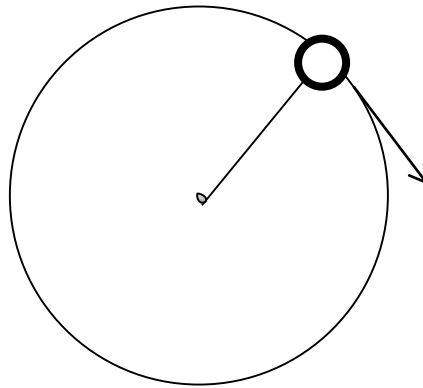

#### Question 1

On the diagram above, draw an arrow to indicate the direction of the gravitational force and the net force on the ball.

1 mark

#### Question 2

Calculate the magnitude of this net force.

N
---

2 marks

**Question 3**

As it is spun, the yo-yo moved at constant speed. Explain how this can be true, while the net force on the ball does not equal zero.

---

---

---

---

---

3 marks

The following information relates to questions 4 to 8:

The string holding a yo-yo breaks and the yo-yo flies off at 10 meters per second at an angle of 60 degrees to the ground, as illustrated in the diagram below. Air resistance can be ignored. The experimenter is 1.6 m tall.

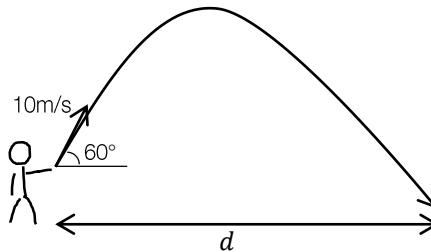

#### Question 4

State whether the following quantities are increasing, remain constant, or are constant and zero for the duration of the yo-yo's motion.

- a. The horizontal component of the yo-yo's velocity

---

- b. The vertical component of the yo-yo's acceleration

---

2 marks

**Question 5**

What is the maximum height reached by the yo-yo in motion?

 m

2 marks

**Question 6**

What is the object's velocity the moment before it hits the ground?

 m s<sup>-1</sup>

3 marks

**Question 7**

What is the value of  $d$  (the range of the yo-yo)?

 m

3 marks

**Question 8**

On the diagram on the previous page, draw a dotted line to indicate how the trajectory of the projectile would be different if air resistance was not ignored.

2 marks

*The following information relates to questions 9 to 12:*

A 50 g mass is attached to the end of the spring (which can be modelled as an ideal spring) with a length of 16 cm. A force of 14 N is applied to the spring and the spring is compressed by 4 cm.

**Question 9**

What is the value of the spring constant,  $k$ ?

2 marks

**Question 10**

What is the potential energy in this system as the spring is compressed to this length?

2 marks

**Question 11**

What is the maximum velocity of the mass in this system as the spring is oscillating?

2 marks

**Question 12**

If the spring had a resistance, describe the motion of the spring over time with reference to the principle of conservation of energy.

---

---

---

---

3 marks

**Question 13**

A comet is in orbit around the sun. The mass of the comet is  $3.7 \times 10^{22}$  kg, and the radius of the comet's orbit around the sun is  $7.2 \times 10^9$  m.

Calculate the period of the comet's orbit. Be sure to include appropriate units when giving your answer.

5 marks



*The following information relates to questions 14 to 16:*

Casey's Comet is on a collision course with a planet of the same mass. It is travelling at 1000 m/s when it collides with the planet, which was travelling in the opposite direction at 720 m/s. After the collision the comet comes to a rest and the planet travels in the opposite direction to its original trajectory. Both the comet and planet retained their masses.

**Question 14**

In this collision, what quantity is conserved?

---

1 mark

**Question 15**

What is the total kinetic energy of planet immediately after the collision?

J
---

2 marks

**Question 16**

Calculate the kinetic energy before the collision and the kinetic energy after the collision and show that it does not satisfy the conservation of energy. Explain where this energy has gone.

5 marks

## Part 2: Electronics and photonics

The following information relates to questions 1 to 4:

An electronic circuit was set up in the following figure. The circuit consists of a 12 V battery and four resistors, where  $R_1 = R_2 = R_3 = R_4 = 6 \Omega$ .

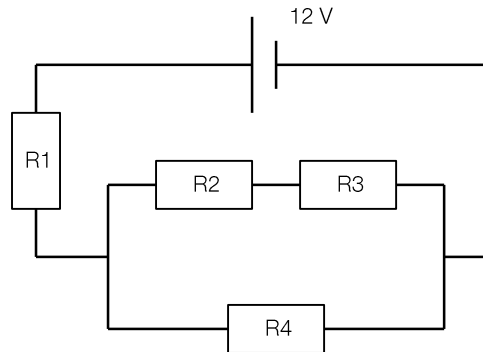

### Question 1

Calculate the equivalent resistance of the whole circuit.

2 marks

### Question 2

Calculate the potential difference (voltage drop) across R1.

2 marks

**Question 3**

Calculate the power dissipated across R2.

W
---

1 mark

**Question 4**

If were to measure the current and potential difference across R2, draw on the figure where you would place an ammeter and a voltmeter could be connected to do this.

3 marks

**Question 5**

An amplifier has an input voltage of 80 mV and an output voltage of 20 V. What is its gain?

1 mark

**Question 6**

The temperature-resistance characteristic of a thermistor is shown in the following figure.

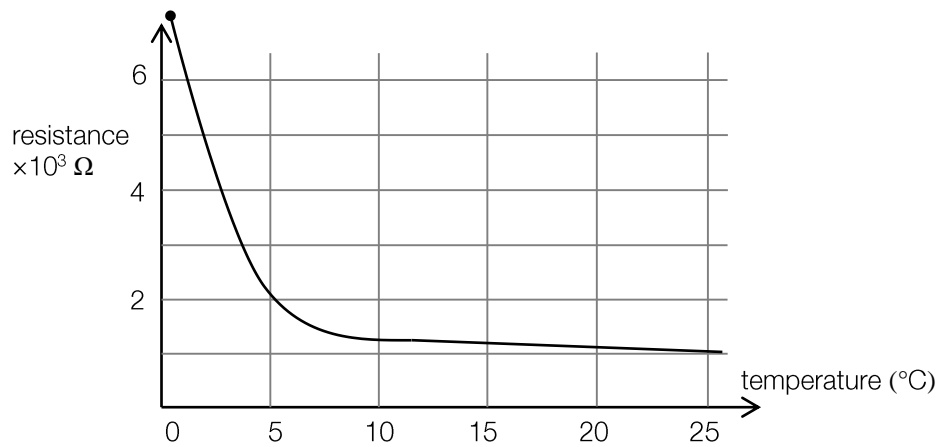

a. What is the resistance of the thermistor when the temperature is 5°?

kΩ

1 mark

The thermistor is incorporated into a circuit to control an air conditioner. The figure of the circuit is shown below.

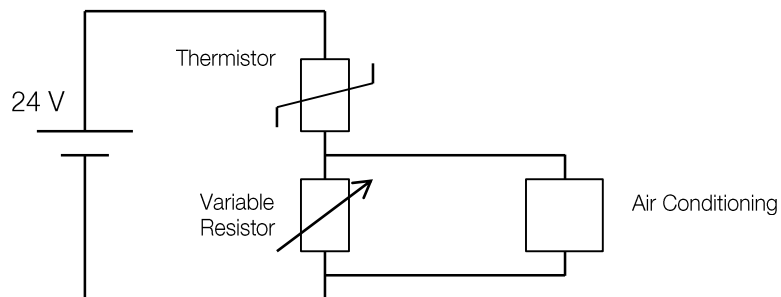

The air conditioning switches on when the voltage across the input of the switch reaches 16 V and switches off when the voltage drops below 16 V.

The air conditioning should switch on when the temperature rises to 25°C.

b. Calculate the required resistance for the variable resistor.

kΩ

2 marks

The air conditioner now needs to come on at a lower temperature.

- c. State whether the variable resistor should be increased or decreased to achieve this. Explain why.

---

---

---

---

---

---

---

4 marks

**Question 7**

An experiment is conducted with a light emitting diodes (LEDs). The current–voltage characteristic of these LEDs are shown in the figure below.

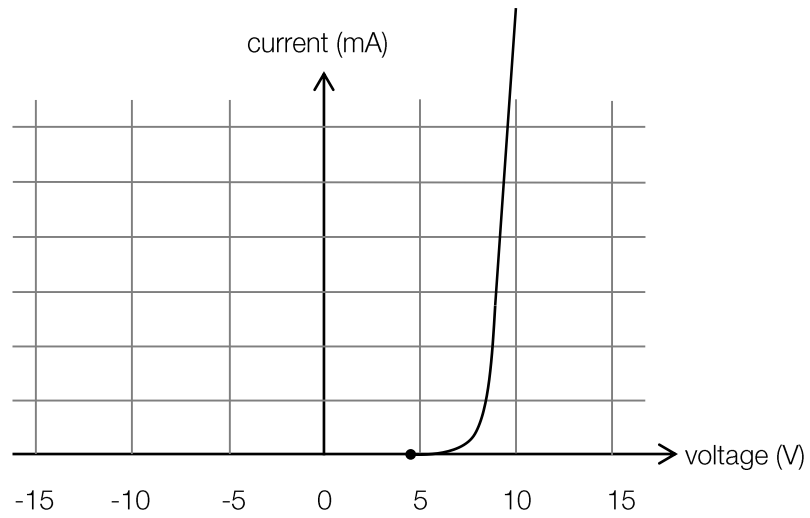

Four identical LEDs and a resistor are set up, as shown in the following diagram.

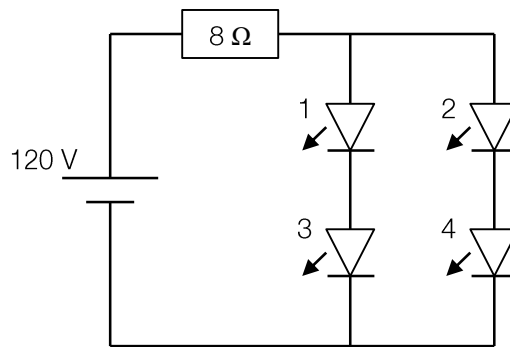

a. Calculate the voltage across the  $8\Omega$  resistor.

V

1 mark

b. Calculate the current that flows through the  $8\Omega$  resistor.

mA

1 mark

In the process of setting up the experiment a LED was placed in the opposite orientation, shown in the following figure.

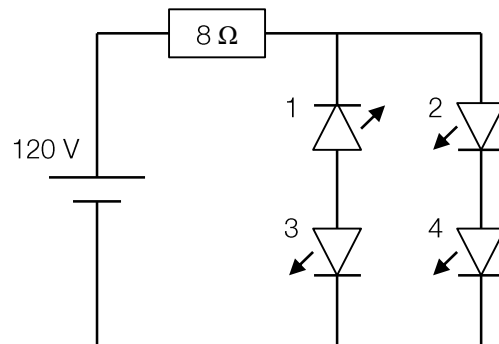

c. Indicate by ticking the boxes below which LEDs switch on when the power supply is connected.

1	2	3	4
---	---	---	---

2 marks



**Part 3: Electric power**

Use the information below to answer questions 1 to 4:

A solenoid is constructed and used in a circuit as shown below.

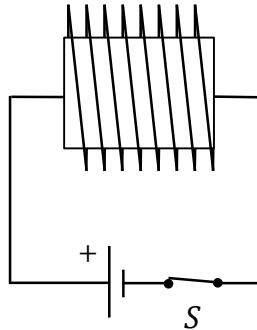
**Question 1**

Draw field lines to indicate the magnetic field of the solenoid. Include at least 4 field lines.

2 marks

Initially, switch  $S$  is closed and the current passes through the solenoid. There is a uniform magnetic field inside the solenoid of strength  $6.0 \times 10^{-2}$  T. (You can ignore any magnetic fields produced outside the solenoid). A looped wire of a radius 15 cm is placed inside the solenoid so that the magnetic field lines thread the loop (You can assume that the surface area of the loop and magnetic field lines are perpendicular).

**Question 2**

Calculate the magnetic flux threading the loop of wire while it is in the solenoid.

Wb
----

1 mark

**Question 3**

The loop of wire is pulled out of the solenoid and it takes 5 seconds for it to be completely removed and now has no magnetic field lines threading it. Calculate the electromotive force produced in the loop of wire.

mV
----

3 marks

**Question 4**

Explain your answer to question 3 with particular reference to Lenz's law.

---

---

---

---

---

---

---

---

---

---

4 marks

Use the information below to answer questions 5 to 10:

A farm house is powered by a distant generating station. Power is generated at a voltage of  $320 V_{\text{RMS}}$  and with a current of  $2000 A_{\text{RMS}}$ .

The current is passed through ideal step-up transformer before transmission through power lines. The transformer has 8 turns on the primary coil and 800 turns on the secondary coil. An ideal step-down transformer (with 800 turns on the primary coil and 8 turns on the secondary coil) is located at a substation nearby to the factory.

**Question 5**

What is the input voltage to the transmission line?

2 marks

**Question 6**

The wires of the transmission lines have an equivalent resistance of  $50 \Omega$ . Calculate the power loss in the transmission wires.

2 marks

**Question 7**

What is the loss in voltage through the transmission lines?

1 mark

**Question 8**

What is the voltage available at the farm house?

2 marks

**Question 9**

The power lines run north to south, parallel to the ground. If the strength of earth's magnetic field is  $5.8 \times 10^{-5}$  T, find the magnitude and direction of the force on 1 km of a single transmission wire.

N
---

2 marks

**Question 10**

Outline the benefits of using AC for transmission compared to DC of electricity.

---

---

---

---

---

---

---

---

4 marks

Use the following information to answer questions 11 to 14:

The figure below shows a schematic for DC power generation. A square coil  $ABCD$  is rotated in a magnetic field by mechanical input, and a voltage is generated across terminals  $T_1$  and  $T_2$ . The coil is rotating at 20 revolutions per second counterclockwise along the axis  $PQ$ .

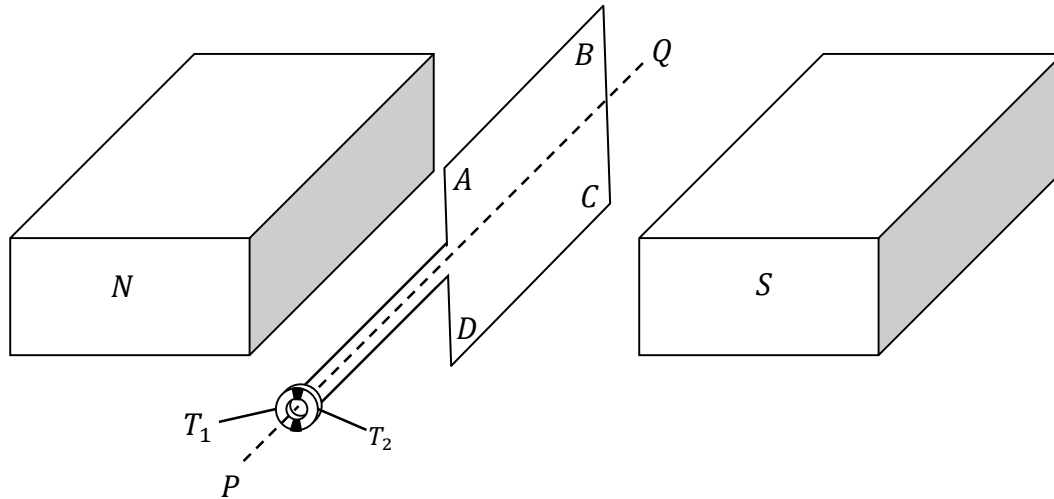

**Question 11**

Identify the mechanism that joins the terminals to the armature and briefly explain its function.

---



---



---



---



---



---



---



---

3 marks

**Question 12**

If the strength of the magnetic field is 0.7 T, and the coil has side length 15 cm, find the maximum voltage across  $T_1$  and  $T_2$ , correct to two decimal places.

V
---

2 marks

**Question 13**

Explain the difference in function between a *split-ring commutator* and *slip rings*. Describe the situations in which a split-ring commutator and slip rings could be used.

---

---

---

---

---

---

---

---

3 marks

**Question 14**

Which of the following correctly shows the EMF generated by the coil as a function of time?

A.

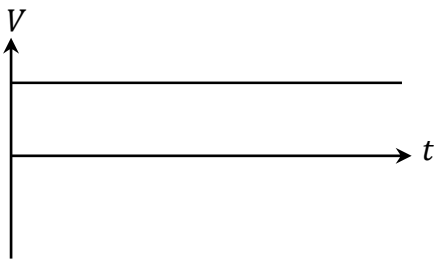

B.

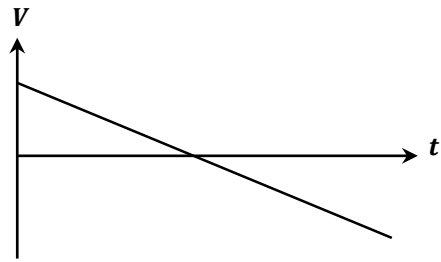

C.

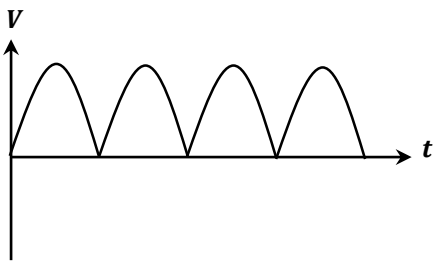

D.

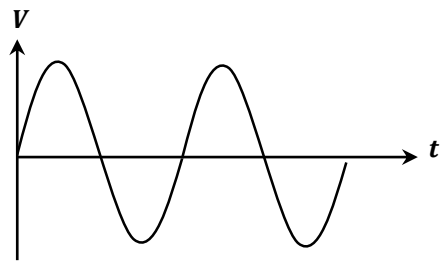

E.

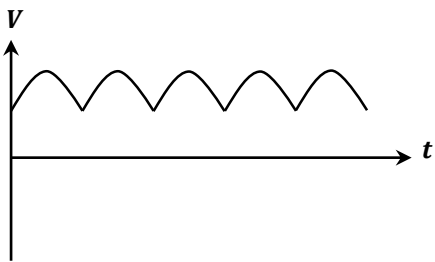

2 marks

**Question 15**

Which of the above correctly shows the EMF generated by the coil as a function of time, if a split-ring commutator was used instead?

2 marks

Use the following information to answer questions 16 to 18:

A square coil of wire of side length 5.0 cm, with terminals *A* and *B*, is held perpendicular to a uniform magnetic field of strength  $4.6 \times 10^{-2}$  T, as shown below. Assume the field is zero outside the large square.

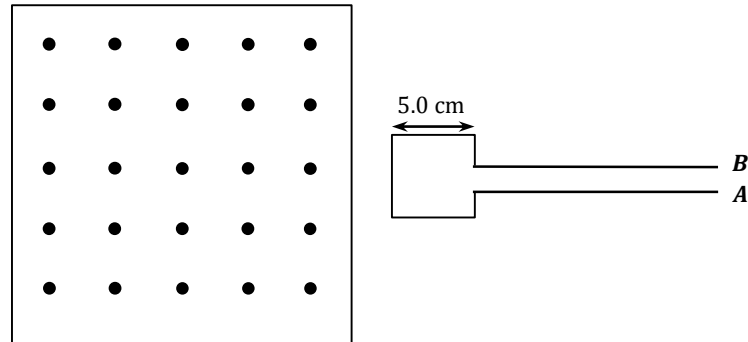

A graph of the flux threading the coil of wire is shown below.

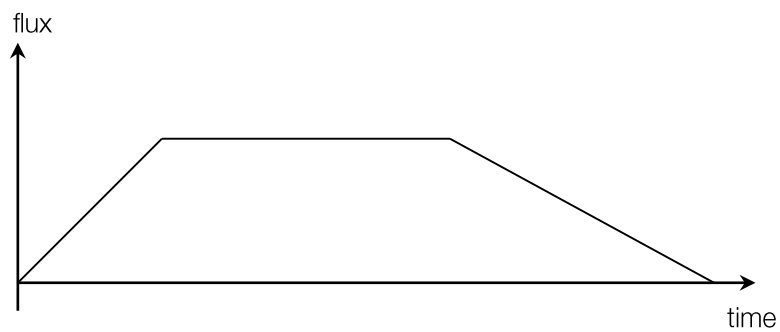

### Question 16

Draw a graph of the induced emf in the loop as a function of time, where current from *A* to *B* is positive. (You do not need to label values on your graph)



2 marks



**Question 17**

Explain your answer to question 16 with particular reference to a physical law.

---

---

---

---

---

---

---

---

---

---

3 marks

**Question 18**

If the square wire was placed inside the magnetic field and the magnetic field strength decreased, describe the direction of current in the square wire (from A to B or from B to A).

---

---

2 marks

*Part 4: Interactions of light and matter***Question 1**

Provide an example of an historical experiment that supports the particle model. Explain how it does this.

---

---

---

---

---

---

---

---

---

---

2 marks

**Question 2**

Provide an example of an historical experiment that supports the wave model. Explain how.

---

---

---

---

---

---

---

---

---

---

3 marks

**Question 3**

An experiment is conducted in which a light source is shone on a plate of zinc, and the energy of the emitted electrons is observed. Explain the effect (if any) that increasing the intensity of this light would have on the energy of the emitted electrons.

---

---

---

---

---

---

---

---

2 marks

**Question 4**

State and explain two key differences between light received from the sun and light emitted from a laser.

---

---

---

---

---

---

---

---

3 marks

Use the following information to answer questions 5 and 6:

A student experiments with a light source and a selenium plate. With the selenium plate placed in front of a light source and a photoelectron detector placed nearby as well the student recorded a graph of the maximum kinetic energy of the photoelectrons versus the frequency of the light:

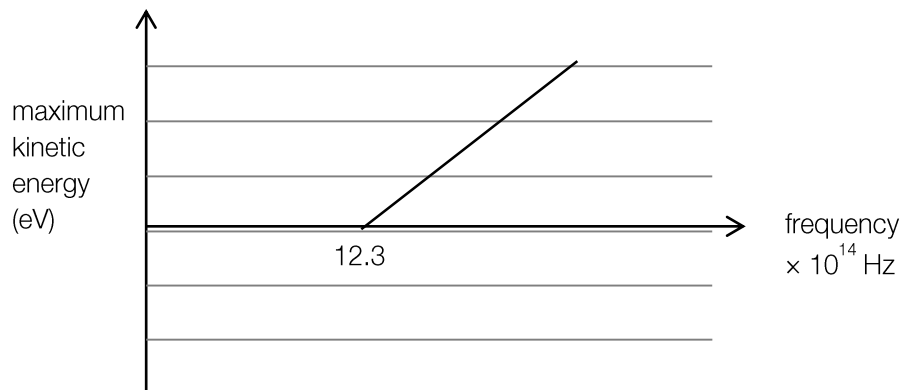

### Question 5

What effect does doubling the intensity have on the graph?

---

---

2 marks

### Question 6

The selenium plate is now replaced with a magnesium plate, which has a lower work function. What effect does this now have on the graph if we double the light intensity?

---

---

---

---

---

---

---

---

3 marks

**Question 7**

A source is used to produce X-rays for crystallography. The energy of one X-ray photon is measured to be 9.0 keV. What is the wavelength of these X-rays?

m
---

2 marks

**Question 8**

Explain why the electron beam produces a similar diffraction pattern to the x-ray beam.

---

---

---

---

---

2 marks

**Question 9**

Calculate the maximum velocity of electrons that are emitted from a selenium surface ( $\phi = 5.11$  eV) when electromagnetic radiation of wavelength 240 nm illuminates it.

$\text{m s}^{-1}$
-------------------

3 marks

**Question 10**

An atom is in a given excited state, and is capable of emitting a photon with one possible value of energy. Which excited state is this atom in? Explain.

---

---

---

1 mark

**Question 11**

On the diagram below, indicate with an arrow the possible transitions for an electron that produces a wavelength of 654 nm.

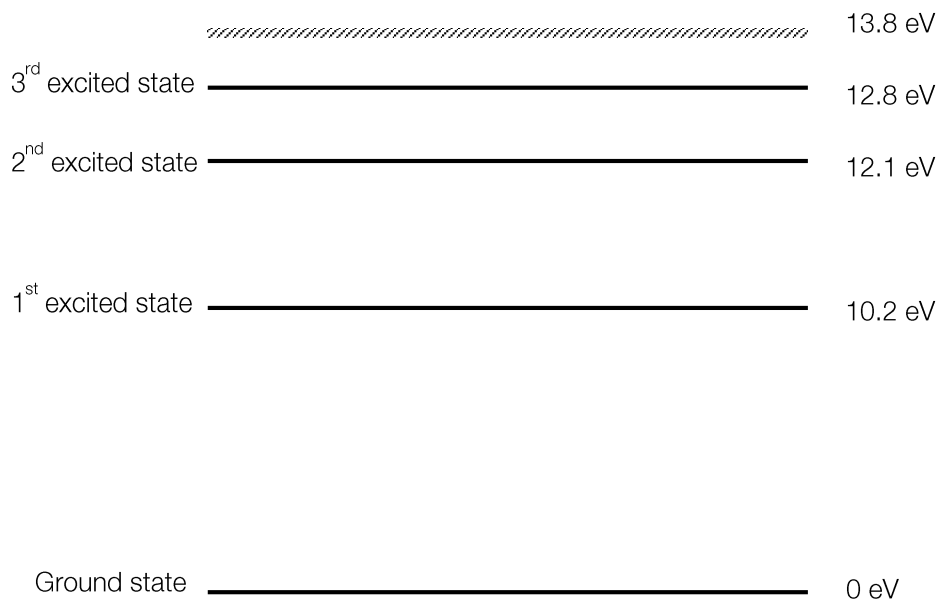

1 mark

**Question 12**

With reference to standing waves, outline how the De Broglie hypothesis helps explain the quantized energy states of atoms.

---

---

---

2 marks

## ***Section B – Detailed Studies***

### ***Instructions***

Select **one** detailed study.

Answer all questions by circling your choice.

Choose the response that is correct or that best answers the question.

A correct answer scores 2, an incorrect answer scores 0.

Marks will not be deducted for incorrect answers.

No marks will be given if more than one answer is completed for any question.

You should take the value of  $g$  to be  $10 \text{ m s}^{-2}$ .

### *Einstein's special relativity*

#### Question 1

An alien on a distant planet witnesses his spaceship being stolen. The spaceship is travelling at  $2.8 \times 10^8 \text{ m s}^{-1}$  relative to the alien. He knows the proper length of his spaceship is 52 m. What length does the spaceship appear when the thief drives it past?

- A. 18.7 m
- B. 26 m
- C. 52 m
- D. 144.8 m

#### Question 2

Two space ships are travelling in the same direction both at speed comparable to the speed of light. The front spaceship views the second spaceship approaching it from behind at  $0.3c$ . At the instant the spaceships are  $7.5 \times 10^5 \text{ km}$  apart the second spaceship flashes its light at the first spaceship. How long does it take for the first ship to see the flash?

- A. 2.1 seconds
- B. 2.1 microseconds
- C. 2.5 seconds
- D. 2.5 microseconds

#### Question 3

A particle is placed in an accelerometer with initial speed  $0.99c$ . What best describes the effect of the accelerometer on the particle's mass and speed?

- A. Mass and speed increase substantially
- B. Mass and speed increase slightly
- C. Mass increases substantially; speed increases slightly
- D. Mass increases slightly; speed increases substantially

#### Question 4

Which of the following statements about light is true?

- A. The speed of light is different in all different inertial frames of references.
- B. The speed of light changes as other measurements, such as length, change
- C. The speed of light reduces as the inertial frame of reference approaches the speed of light.
- D. The speed of light is a constant

#### Question 5

How much work must be done on an electron to increase its speed from zero to  $0.9c$ ?

- A.  $8.2 \times 10^{-14} \text{ J}$
- B.  $1.1 \times 10^{-13} \text{ J}$
- C.  $1.7 \times 10^{-13} \text{ J}$
- D.  $1.9 \times 10^{-13} \text{ J}$



**Question 6**

A toddler is going down a slide at  $u$  m s<sup>-1</sup> while holding a camera. The toddler is grumpy so throws the camera, and views it going away from him at  $v$  m s<sup>-1</sup>. The instant the toddler lets go of the camera the flash goes off. The best description for the speed of the camera and light from the flash is:

- |    | Camera  | Light   |
|----|---------|---|
| A. | $V$     | $c$   |
| B. | $V$     | $V + \frac{1}{\sqrt{1 - \left(\frac{v}{c}\right)^2}}$ |
| C. | $U + V$ | $c$   |
| D. | $U + V$ | $V + \frac{1}{\sqrt{1 - \left(\frac{v}{c}\right)^2}}$ |

**Question 7**

Which of the following best describes the findings of the Michelson-Morley experiment?

- A. Special Relativity
- B. The speed of light is constant in all directions close to the earth's surface
- C. The speed of light is constant close to the surface of the earth as the luminiferous ether does not exist in earth's atmosphere
- D. the results were non-conclusive

**Question 8**

An alien ship is speeding towards Earth at  $0.95c$  and the aliens know it will take them 14 days to arrive on Earth (in their frame of reference). How long, according to the inhabitants of Earth, will it be until the aliens arrive?

- A. 4.37 days
- B. 13.3 days
- C. 44.8 days
- D. 62.6 days

**Question 9**

The kinetic energy of an electron is  $6.3 \times 10^{-14}$  J. What is the total energy of the electron?

- A.  $6.3 \times 10^{-14}$  J
- B.  $1.4 \times 10^{-13}$  J
- C.  $6.3 \times 10^{-13}$  J
- D.  $1.4 \times 10^{-12}$  J

**Question 10**

Which of the following are inertial reference frames?

- i. The earth's surface
- ii. A plane accelerating for take off

- A. only i
- B. only ii
- C. both i and ii
- D. neither i nor ii

**Question 11**

A particle has a Lorentz factor of 5. What is the speed of the particle?

- A.  $0.92c$
- B.  $0.94c$
- C.  $0.96c$
- D.  $0.98c$

## Materials and their use in structures

The following information relates to questions 1 to 6:

Engineers are designing a building and are investigating different steels for use in its construction. They test a sample of hard steel and a sample of soft steel, measuring the extension as tensile force is applied.

A force-extension graph is shown below for both hard steel and soft steel.

The hard steel breaks at X and soft steel breaks at Y.

The hard steel has an unstretched length of 12 cm and a cross-sectional area of  $2.5 \times 10^{-6} \text{ m}^2$ .

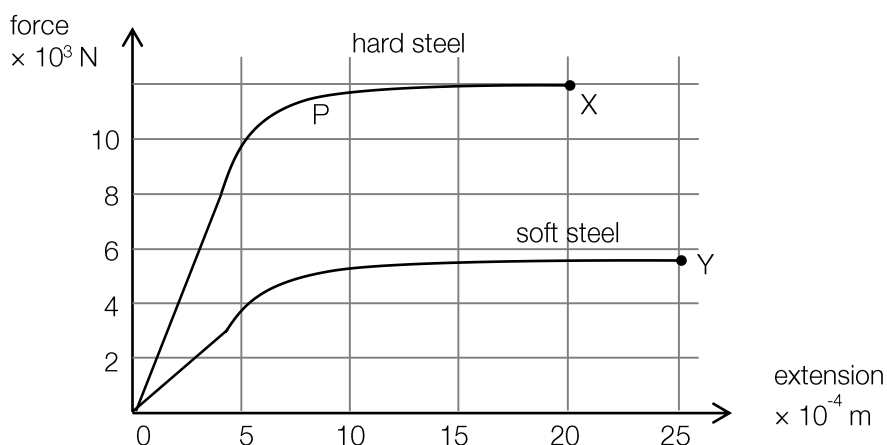

### Question 1

From the graph, compared to hard steel, soft steel can be best described as

- A. stiff
- B. strong
- C. brittle
- D. ductile

### Question 2

Which of the following is closest to the strain in the hard steel when a force of  $1.0 \times 10^4 \text{ N}$  is applied?

- A.  $4.2 \times 10^{-3}$
- B.  $4.2 \times 10^{-5}$
- C.  $5.0 \times 10^{-4}$
- D.  $5.0 \times 10^{-3}$

### Question 3

Which of the following is closest to the stress in the sample when a force of  $1.0 \times 10^4 \text{ N}$  is applied?

- A.  $3.3 \times 10^8 \text{ N m}^{-2}$
- B.  $3.3 \times 10^3 \text{ N m}^{-2}$
- C.  $4.0 \times 10^3 \text{ N m}^{-2}$
- D.  $4.0 \times 10^8 \text{ N m}^{-2}$

**Question 4**

Which of the following gives the best estimate of the Young's modulus for hard steel?

- A.  $6.6 \times 10^{10} \text{ N m}^{-2}$
- B.  $7.9 \times 10^8 \text{ N m}^{-2}$
- C.  $7.9 \times 10^{10} \text{ N m}^{-2}$
- D.  $9.5 \times 10^{10} \text{ N m}^{-2}$

**Question 5**

Which of the following is the best estimate for the amount of energy stored in the sample when a force of  $1.0 \times 10^4 \text{ N}$  is applied?

- A. 5.0 J
- B. 2.5 J
- C. 347 J
- D. 174 J

**Question 6**

Which of the following is the best estimate of the toughness of hard steel?

- A.  $3.3 \times 10^6 \text{ J m}^{-3}$
- B.  $6.7 \times 10^{10} \text{ J m}^{-3}$
- C.  $6.7 \times 10^6 \text{ J m}^{-3}$
- D.  $3.3 \times 10^8 \text{ J m}^{-3}$

The following information relates to questions 7 to 9:

A sign hangs of a balcony 15m from the wall. A supporting pole at an angle of 30 degrees from the wall supporting the balcony. The balcony weighs 10 kg and the sign 1.5 kg and their orientation is shown.

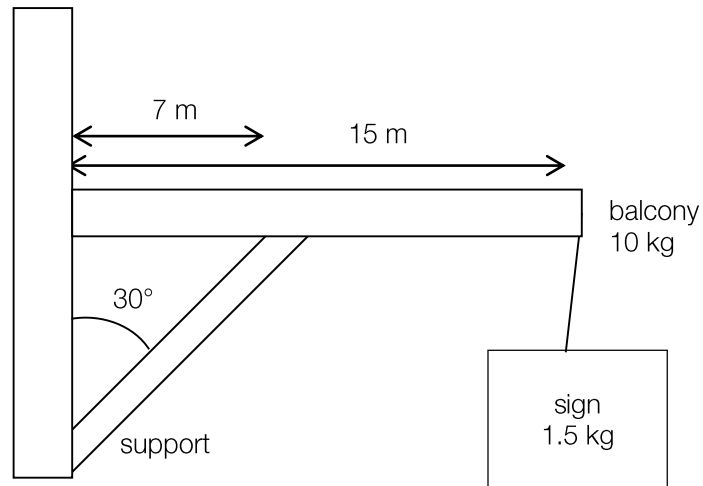

#### Question 7

Which of the following is the torque produced by the sign from the wall?

- A. 105 N m
- B. 225 N m
- C. 33 N m
- D. 330 N m

#### Question 8

Which of the following is the torque produced by balcony from the wall?

- A. 700 N
- B. 750 N
- C. 75 N
- D. 70 N

#### Question 9

Which of the following is the magnitude of the compressive force which the supporting beam is under?

- A. 330 N
- B. 279 N
- C. 139 N
- D. 161 N

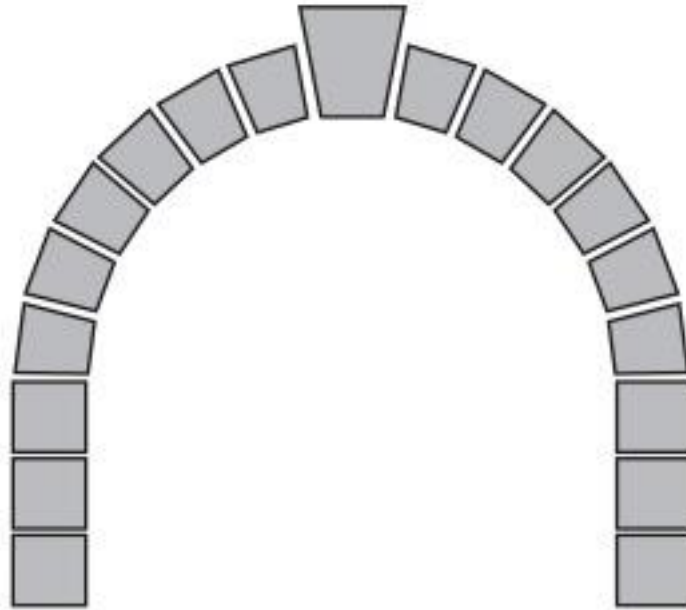
**Question 10**

This figure above shows a stone arch made up of stone blocks. There is no cohesive material between the blocks to bind them together.

Stone is used in this stone arch because it requires a material which is:

- A. strong under shear stress
- B. weak under tensile stress
- C. strong under compressive stress
- D. ductile under compressive stress

**Question 11**

A balcony is made of concrete, which is strong under compression, but not under tension. To reinforce the concrete, steel wires (strong under tension) are set inside the concrete.

Which of the following describes the best placement of the steel wires in the balcony?

- A. Near the bottom of the concrete slab between the two supports
- B. In the centre of the concrete slab
- C. Around the concrete slab
- D. Near the top of the concrete slab for the whole length

*Further electronics***Question 1**

The input voltage to a transformer is  $240\text{ V}_{\text{RMS}}$ , and there are 1200 turns in the primary winding. The peak voltage measured at the output terminals is 40 V. The number of turns in the secondary winding is closest to:

- A. 140
- B. 200
- C. 7200
- D. 6

**Question 2**

A capacitor with a constant of 0.5 seconds, discharges for 0.5 seconds and the potential difference across the capacitor is found to be 12 V. What was the potential difference across the capacitor when it was fully charged?

- A. 32.4 V
- B. 12 V
- C. 4.44 V
- D. 6 V

**Question 3**

The capacitor in question 2 is now used in a circuit that is shown below.

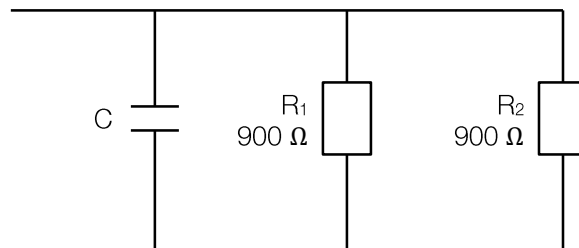

Which one of the following best gives the value of the capacitor?

- A.  $1111\ \mu\text{F}$
- B.  $900\ \mu\text{F}$
- C. 90 F
- D. There is not enough information to determine the capacitance

Use the following information to answer questions 4 and 5:

An AC to DC power supply system for an electric motor is shown in the figure below. The DC voltage has to be approximately 60V and the effective resistance of the motor is  $2\text{k}\Omega$ .

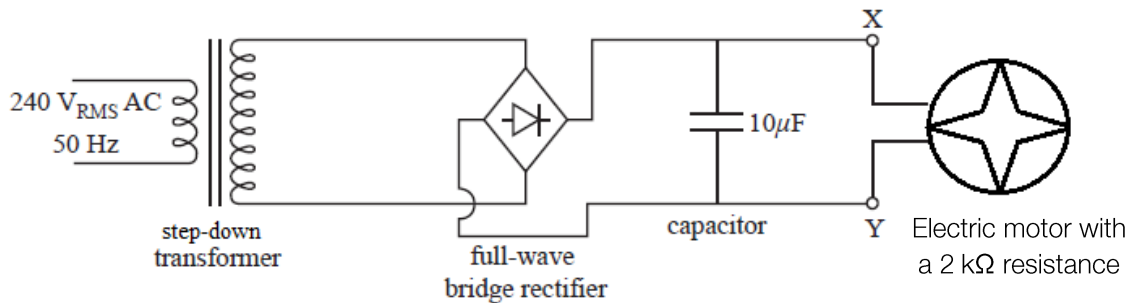

Figure 1

#### Question 4

For the circuit above consisting of the smoothing capacitor and the electric motor, which of the following is the closest to the time constant  $\tau$ ?

- A.  $2 \times 10^{-8}$  s
- B. 0.02 s
- C. 0.01 s
- D.  $2 \times 10^8$  s

#### Question 5

The following signal is obtained from an oscilloscope that is connected in parallel to the capacitor:

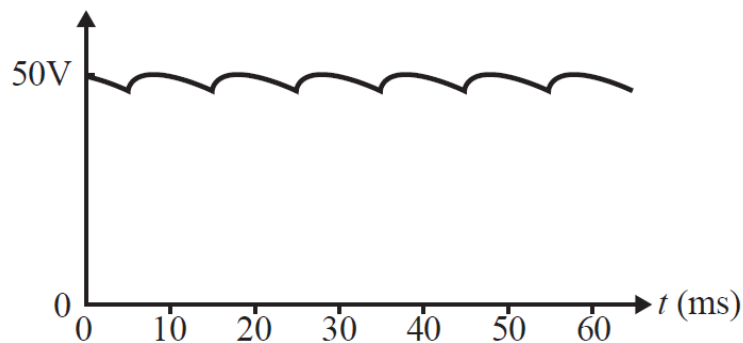

If a smooth signal instead of a bumpy one was more desired, which of the following could not affect the smoothness of the signal?

- A. The capacitance of the capacitor
- B. The resistance of electric motor
- C. The power rating of the transformer
- D. Using a full wave bridge rectifier instead of a single diode



Use the following information to answer questions 6 and 7:

An experiment is set up to test the characteristics of a capacitor. The circuit for which it is arranged is shown in the figure below. The battery is initially turned off.

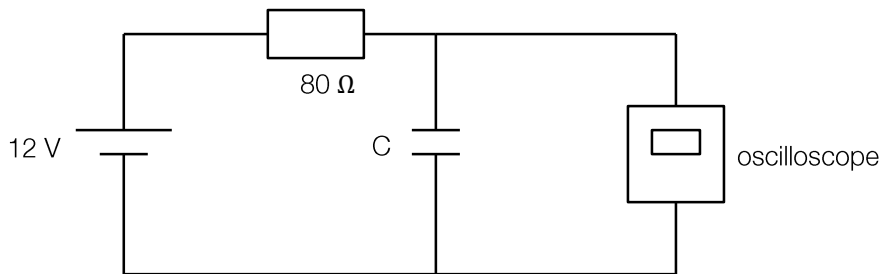

The battery is then turned on and the voltage across the capacitor is observed through the display on the oscilloscope shown in the figure below.

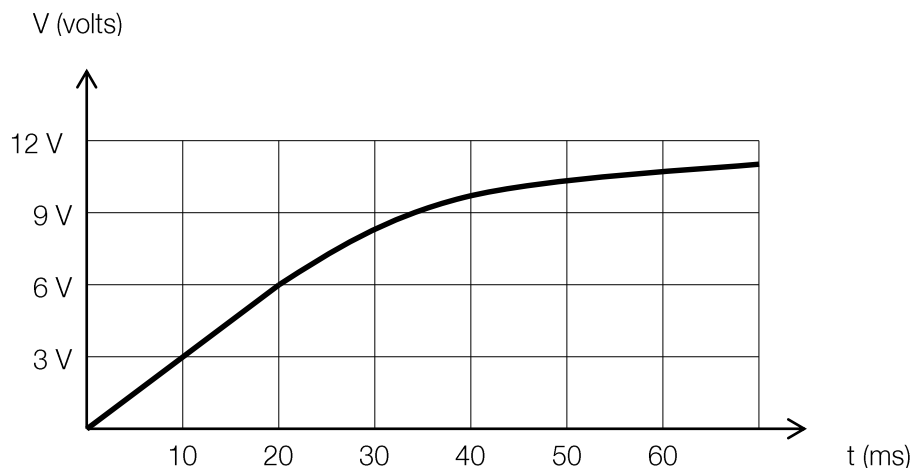

### Question 6

What is the approximate power dissipated by the resistor at 20 ms?

- A. 0.45 W
- B. 6 W
- C. 10 W
- D. 2 kW

### Question 7

Which of the following is the best estimate for the value of the capacitor  $C$ ?

- A.  $200\ \mu\text{F}$
- B.  $250\ \mu\text{F}$
- C.  $150\ \mu\text{F}$
- D.  $100\ \mu\text{F}$

Use the following information to answer questions 8 and 9:

The characteristics of a transformer are determined by connecting it to an oscilloscope. The following diagram is what is displayed on the oscilloscope.

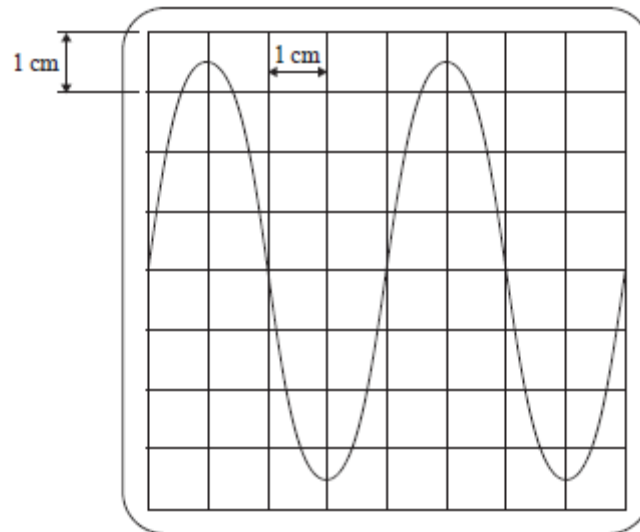

The vertical scale is set to 4 V/cm and the horizontal scale is set to 6 ms/cm.

**Question 8**

Which one of the following gives the closest value of the peak-to-peak voltage of the signal?

- A. 7 V
- B. 14 V
- C. 28 V
- D. 240 V

**Question 9**

Which one of the following gives the closest value of the frequency of the signal?

- A. 24 Hz
- B. 42 Hz
- C. 0.04 Hz
- D. 6 Hz

Use the following information to answer questions 10 and 11:

An experimenter is studying the characteristics of a Zener diode. The voltage-current characteristic of the Zener diode is shown in the diagram below:

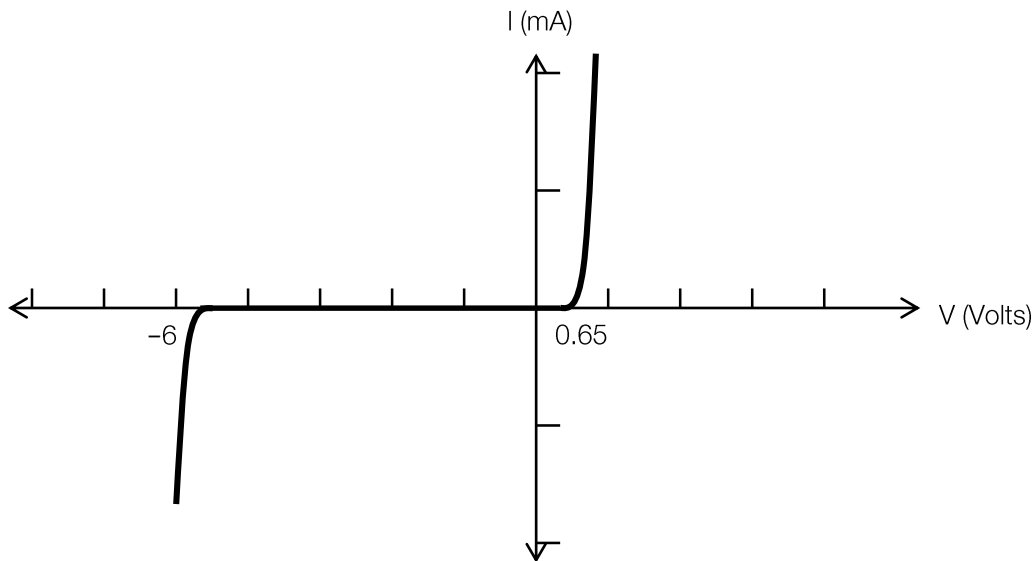

Using the Zener diode with the characteristic shown above, a circuit is constructed:

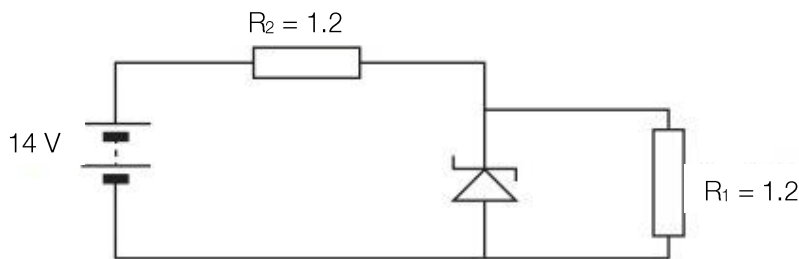

### Question 10

Which of the following best describes the function of the resistor  $R_2$ ?

- A.  $R_2$  limits the total power output
- B.  $R_2$  reduces the voltage across the capacitor
- C.  $R_2$  protects  $R_1$  from excessive current through it
- D.  $R_2$  protects the Zener diode from excessive current through it

### Question 11

Which one of the following gives the closest value of the current through the Zener diode?

- A. 12 mA
- B. 5 mA
- C. 1.2 mA
- D. 1.7 mA

## Synchrotron

### Question 1

The following is an incomplete list of components of a synchrotron.

- I. Wigglers
- II. Undulators
- III. Bending magnets
- IV. Linac

Which of these produce synchrotron radiation?

- A. I and II
- B. I only
- C. I and IV
- D. I, II and III

### Question 2

What is the effect on synchrotron light produced by a wiggler if the strength of the electromagnets is increased?

- A. Synchrotron light is brighter
- B. Synchrotron light is more diffuse
- C. Synchrotron light is more energetic
- D. Synchrotron light is more polarized

### Question 3

Which of the following best describes the purpose of the monochromator?

- A. Focus the beam
- B. Isolate a particular wavelength
- C. Prevent electrons moving through the beamline
- D. Collimate the beam

Use the following information to answer questions 4 to 8:

X-rays of wavelength  $4.3 \times 10^{-10}$  m are being used to investigate the lattice spacing of semiconductor materials using x-ray crystallography. Below is a schematic indicating the scattering of a beam of x-rays, angled at  $\theta^\circ$  to the horizontal, from two layers of atoms separated by a distance,  $d$ .

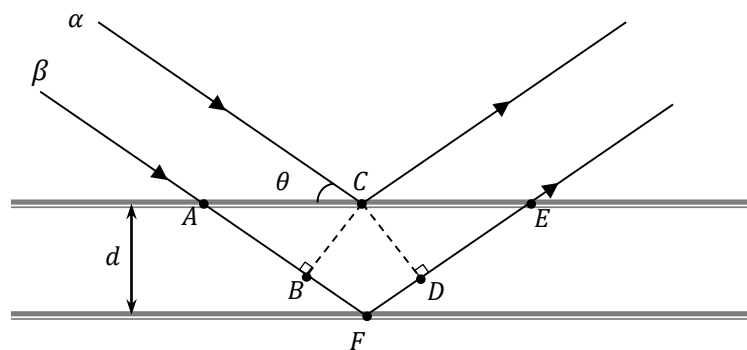

#### Question 4

For the purposes of x-ray crystallography, which of the following combinations of statements best describe the advantages of a synchrotron light source over conventional x-ray sources?

- I. Synchrotrons produce brighter light
  - II. Synchrotrons produce a wider range of wavelengths
  - III. Synchrotrons produce a more collimated beam
  - IV. Synchrotrons are more compact
- A. I and II
  - B. II only
  - C. I, II and III
  - D. All statements are correct

#### Question 5

In the diagram, the path difference between beam  $\alpha$  and beam  $\beta$  results in a phase shift of the reflected beams that can be used to determine the crystal spacing. Which of the following represents the path difference?

- A.  $\overline{AC} + \overline{CE}$
- B.  $\overline{AB} + \overline{DE}$
- C.  $\overline{BF} + \overline{FD}$
- D.  $\overline{CF}$

**Question 6**

Gallium arsenide is a material widely used in semiconductors. It is found to have an atomic spacing of 0.535 nm. Light with wavelength is incident upon the surface of a crystal of gallium arsenide at an angle  $\theta$ , which is varied from  $0^\circ$  to  $90^\circ$ . At what angle is the first diffraction maximum observed?

- A.  $20.3^\circ$
- B.  $23.7^\circ$
- C.  $26.4^\circ$
- D.  $31.1^\circ$

**Question 7**

A sample of zinc selenite is investigated in a similar manner. However, now the angle made by the incident beam to the surface is varied from  $0^\circ$  to  $180^\circ$ . If the first diffraction maximum is observed at  $22.3^\circ$ , what is the atomic spacing of the rubidium nitrate crystal?

- A. 567 pm
- B. 533 pm
- C. 475 pm
- D. 455 pm

**Question 8**

How many diffraction peaks are observed in the experiment described in question 6?

- A. 1
- B. 2
- C. 3
- D. 4

Use the following information to answer questions 9 and 10:

Insertion devices are used in synchrotrons to produce synchrotron radiation. Below is an example of one.

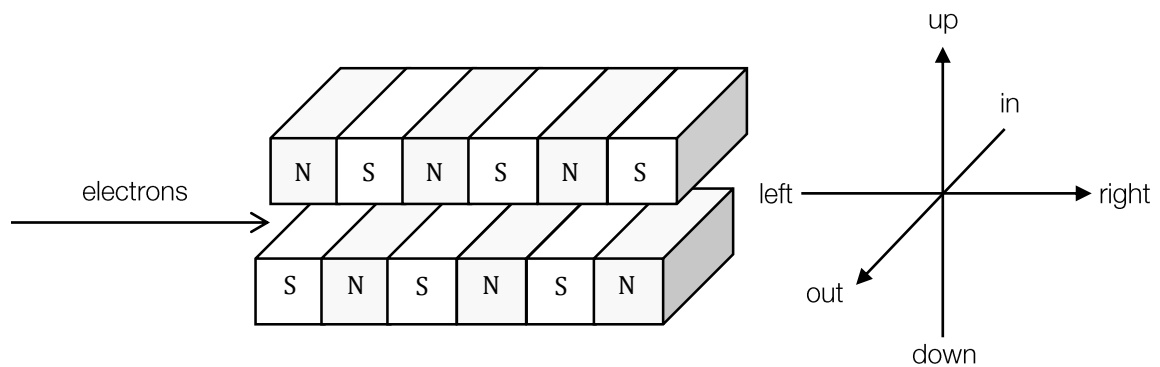

**Question 9**

How do electrons moving into the wiggler behave?

- A. They steadily bend inwards along the length of the device
- B. They oscillate left to right
- C. They oscillate in and out
- D. They oscillate up and down

**Question 10**

Which of the following best describes the direction of emitted synchrotron light?

- A. In
- B. Out
- C. Left
- D. Right

A charged particle undergoes circular motion in the presence of a magnetic field.

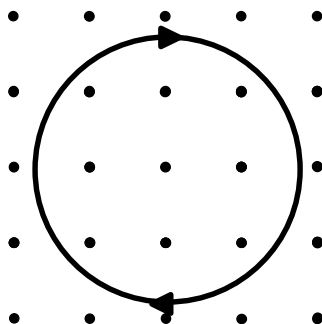

**Question 11**

If the strength of the magnetic field is  $5.4 \times 10^{-5}$  T, the radius is 45 cm, the mass of the particle is  $9.3 \times 10^{-31}$  kg, and the velocity of the particle is  $4.2 \times 10^5$  m/s, which of the following correctly identifies the charge of the particle?

- A.  $-1.57 \times 10^{-19}$  C
- B.  $-6.58 \times 10^{-14}$  C
- C.  $+1.57 \times 10^{-19}$  C
- D.  $+6.58 \times 10^{-14}$  C



## Photonics

### Question 1

Which of the following only contains sources that produce incoherent light?

- A. The sun, incandescent globe light bulb, a green laser
- B. A red laser, stars, incandescent light bulb
- C. The stars, a candle, incandescent light bulb
- D. A red or green laser, a candle, the sun

### Question 2

A LED emits red light wavelength of 650 nm. Which of the following best gives the band-gap energy of the semiconductor material of this diode?

- A. 1.9 eV
- B.  $3 \times 10^{-19}$  eV
- C.  $6.5 \times 10^{-7}$  eV
- D. 5 eV

### Question 3

Which of the following statements about the photons emitted in the production of light in a LED?

- A. Thermal motion of excited valence electrons
- B. The energy of the photon emitted as an electron moves from the valence band to the conduction band corresponds to the difference in energy between the two bands
- C. The energy of the photon emitted as an electron moves from the conduction band to the ground state
- D. Electrons can have only a discrete range of possible energies. They emit photons of a certain energy when they transition to a higher energy level

### Question 4

Which of the following is the main difference between laser light and light from a LED?

- A. Lasers can switch on and off rapidly but LEDs cannot.
- B. Light from a laser is at a higher frequency than light from LEDs.
- C. Laser light is incoherent, but light from a LED is coherent.
- D. Laser light has a narrower spread of frequencies than light from a LED.

### Question 5

When light passes from one optical medium to another (where the two mediums have different refractive indices), which of the following change?

- A. Frequency and wavelength
- B. Speed and frequency
- C. Only speed changes
- D. Wavelength and speed

### Question 6

Which of the following best explains the cause of Rayleigh scattering in optical fibre?

- A. Absorption at the interface of the core and cladding
- B. Excessive sharp bending of optical fibre
- C. Refractive index of cladding being too similar to the refractive index of the core
- D. Small variations in density in the core of the optical fibre

**Question 7**

A graded-index optical fibre has an advantage over a step-index fibre because it reduces the:

- A. Absorption
- B. Modal dispersion
- C. Material dispersion
- D. Rayleigh scattering

*Use the following information to answer questions 8 and 9:*

The diagram below shows a step-index fibre-optic waveguide. The core has a refractive index of 1.78. Total internal reflection occurs at the boundary between cladding and core. Assume the fibre is surrounded by air.

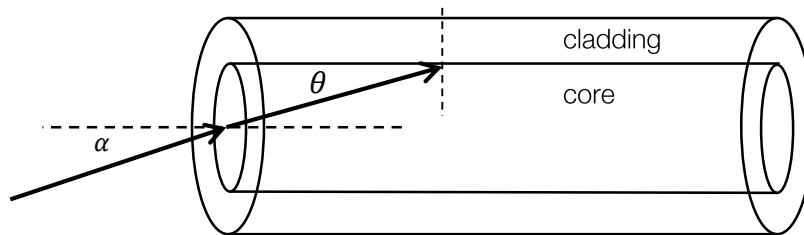
**Question 8**

The angle  $\theta$  indicated on the diagram is  $48^\circ$ . What is the minimal refractive index of the cladding for total internal reflection to occur?

- A. 1.32
- B. 1.00
- C. 1.56
- D. 1.78

**Question 9**

If the fibre was immersed in water, which of the following statements would be correct?

- A. The refractive index of the core would be affected by the fluid
- B.  $\theta$  and  $\alpha$  would both need to increase for total internal reflection to occur
- C.  $\theta$  would be the same, because the relative difference in optical density between core and cladding is unaffected by the fluid
- D. Just  $\alpha$  would need to be increased so total internal reflection could occur

**Question 10**

Calculate the attenuation by Rayleigh scattering if the input power is  $10^{-6}\text{W}$  and the output power was  $10^{-12}\text{W}$ .

- A. 12 dB
- B. 65 dB
- C. 60 dB
- D. 6 dB

**Question 11**

Which of the following statements is true?

- A. All dispersion can be avoided by using a monochromatic light source
- B. An advantage of using a graded-index optical fibre is that modal dispersion is reduced
- C. Using a range of frequencies of light for transmission of a signal can increase the quality of the final signal received
- D. The effects of dispersion on a signal can be rectified by using an amplifier

## Sound

Take the speed of sound in air to be  $340 \text{ m s}^{-1}$ .

### Question 1

Which of the following statements best describes the movement of a dust particle in front of the speaker?

- A. The dust particle oscillates perpendicular to the direction of motion of the sound wave
- B. The dust particle is motionless
- C. The dust particle oscillates in line with the direction of motion of the sound wave
- D. The dust particle is travelling at constant speed away from the speaker

### Question 2

A loudspeaker emits sound with a wavelength of 2 m. What is the frequency of this sound?

- A. 1.7 kHz
- B. 170 Hz
- C. 0.34 kHz
- D. 85 Hz

### Question 3

Albert is standing still on the grandstand when a race car drives past him playing music. Which of the following statements is most accurate?

- A. He observes a change in pitch of the music when the race car passes him, due to diffraction effects
- B. He observes a change in pitch of the music when the race car passes him, due to the Doppler effect
- C. He and the driver both observe a change in pitch of the music when the race car passes Albert, due to the Doppler effect
- D. No change in pitch is observed

### Question 4

As the race car approaches Albert, it is travelling at  $120 \text{ km h}^{-1}$ , and he observes the average frequency of the music as 700 Hz. What average frequency would the driver of the ambulance hear?

- A. 700 Hz
- B. A frequency lower than 700 Hz
- C. A frequency higher than 700 Hz
- D. More information is needed

### Question 5

The race car arrives at its destination, but for a few minutes the music remains on. During those minutes, Albert starts to walk towards the race car, stops, and then forgot his wallet so he turned around and walked back. Which of the following best describes the frequencies she observed once the ambulance had stopped?

- A. Slightly higher than 500 Hz, 500 Hz, slightly lower than 500 Hz
- B. Slightly lower than 500 Hz, 500 Hz, slightly higher than 500 Hz
- C. She heard exactly 500 Hz throughout her movement
- D. 600 Hz, 500 Hz, 400 Hz

Use the following information to answer questions 6 to 8:

Sam is pouring water into a PVC pipe (shown in the diagram below). At the mouth of the pipe is placed a machine that produces sound at variable frequencies.

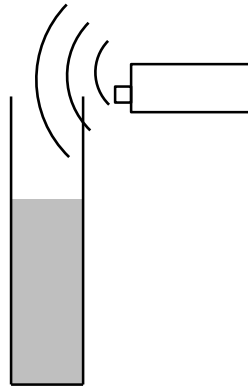

#### Question 6

When the water is 16 cm from the mouth of the pipe, Sam adjusts the frequency until there is the first noticeable increase in the volume of sound from the pipe setup. What is the frequency of the sound when this occurs?

- A. 2.12 kHz
- B. 1.06 kHz
- C. 708 Hz
- D. 531 Hz

#### Question 7

Sam now sets the frequency at a constant 800 Hz. How far from the mouth of the pipe would you expect the water level to be when there is an increase in volume?

- A. 8.00 cm
- B. 800 cm
- C. 10.6 cm
- D. 34 cm

#### Question 8

Which of the following statements is true?

- A. At the surface of the water there is a displacement node and a pressure node
- B. At the surface of the water there is a displacement node and a pressure antinode
- C. At the mouth of the pipe there is a displacement node and a pressure antinode
- D. At the mouth of the pipe there is a displacement antinode and a pressure antinode

**Question 9**

The loudness scale (phon) specifically takes account of which one of the following factors?

- A. Intensity of sound, as perceived by human hearing, is inversely proportional to distance from the source.
- B. The perception of sound by human hearing is logarithmic.
- C. The perception of the intensity of sound by human hearing varies with frequency.
- D. Human hearing has a very limited range of frequencies.

Use the following information to answer questions 10 and 11:

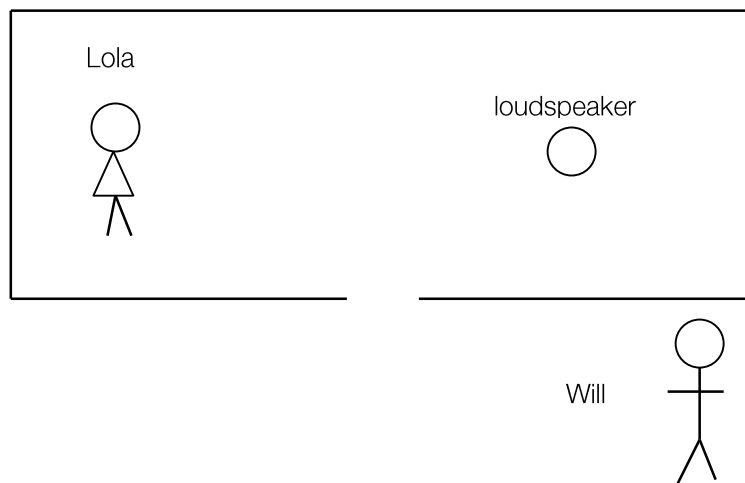
**Question 10**

Lola is standing 2 m away from the loudspeaker, which is emitting sound with a wavelength of 60 cm equally in all directions. She hears the sound at 60 dB. What is the intensity of the sound where Lola is standing?

- A.  $10 \times 10^{-6} \text{ W m}^{-2}$
- B.  $5.0 \times 10^{-6} \text{ W m}^{-2}$
- C.  $6.0 \times 10^{-6} \text{ W m}^{-2}$
- D.  $1.0 \times 10^{-6} \text{ W m}^{-2}$

**Question 11**

Instead of producing sound at a constant frequency, the loudspeaker now begins to play a song. Will is shown standing just outside the door. Which of the following is true for Will?

- A. He does not hear the sound it produces
- B. He hears the song perfectly
- C. He hears the song, but distorted: the higher frequencies are louder
- D. He hears the song, but distorted: the lower frequencies are louder

End of Booklet

**Formula sheet**

1	velocity; acceleration	$v = \frac{\Delta x}{\Delta t}; a = \frac{\Delta v}{\Delta t}$
2	equations for constant acceleration	$v = u + at$ $x = ut + \frac{1}{2}at^2$ $v^2 = u^2 + 2ax$ $x = \frac{1}{2}(v + u)t$
3	Newton's second law	$\Sigma F = ma$
4	circular motion	$a = \frac{v^2}{r} = \frac{4\pi^2 r}{T^2}$
5	Hooke's law	$F = -kx$
6	elastic potential energy	$\frac{1}{2}kx^2$
7	gravitational potential energy near the surface of the Earth	$mgh$
8	kinetic energy	$\frac{1}{2}mv^2$
9	Newton's law of universal gravitation	$F = G \frac{M_1 M_2}{r^2}$
10	gravitational field	$g = G \frac{M}{r^2}$
11	acceleration due to gravity at Earth's surface	$g = 10 \text{ m s}^{-1}$
12	voltage; power	$V = RI; P = VI = I^2 R$
13	resistors in series	$R_T = R_1 + R_2$
14	resistors in parallel	$\frac{1}{R_T} = \frac{1}{R_1} + \frac{1}{R_2}$
15	transformer action	$\frac{V_1}{V_2} = \frac{N_1}{N_2}$
16	AC voltage and current	$V_{RMS} = \frac{1}{\sqrt{2}} V_{p-p}; I_{RMS} = \frac{1}{\sqrt{2}} I_{p-p}$
17	magnetic force	$F = IlB$
18	electromagnetic induction	emf: $\epsilon = -N \frac{\Delta \phi}{\Delta t}$ ; flux: $\phi = BA$

19	transmission losses	$V_{drop} = I_{line}R_{line} \quad P_{loss} = I_{line}^2R_{line}$
20	mass of the electron	$m_e = 9.1 \times 10^{-31} \text{ kg}$
21	charge on the electron	$e = -1.6 \times 10^{-19} \text{ C}$
22	Planck's constant	$h = 6.63 \times 10^{-34} \text{ J s}$ $h = 4.14 \times 10^{-15} \text{ eV s}$
23	speed of light	$c = 3.0 \times 10^8 \text{ m s}^{-1}$
24	photoelectric effect	$E_{Kmax} = hf - W$
25	photon energy	$E = hf$
26	photon momentum	$p = \frac{h}{\lambda}$
27	de Broglie wavelength	$\lambda = \frac{h}{p}$
28	speed, frequency and wavelength	$v = f\lambda$
29	energy transformations for electrons in an electron gun (<100 keV)	$\frac{1}{2}mv^2 = eV$
30	radius of electron path	$r = \frac{mv}{eB}$
31	magnetic force on a moving electron	$F = evB$
32	Bragg's law	$b\lambda = 2d \sin \theta$
33	electric field between charged plates	$E = \frac{V}{d}$
34	band gap energy	$E = \frac{hc}{\lambda}$
35	Snell's law	$n_1 \sin \theta_1 = n_2 \sin \theta_2$
36	intensity and level	sound intensity level (in dB) $L = 10 \log_{10} \left( \frac{I}{I_0} \right)$ where $I_0 = 1.0 \times 10^{-12} \text{ W m}^{-2}$
37	Lorentz factor	$\gamma = \frac{1}{\sqrt{1 - v^2/c^2}}$
38	time dilation	$t = t_0\gamma$



39	length contraction	$L = \frac{L_0}{\gamma}$
40	relativistic mass	$m = m_0\gamma$
41	total energy	$E_{total} = E_k + E_{rest} = mc^2$
42	stress	$\sigma = \frac{F}{A}$
43	strain	$\epsilon = \frac{\Delta L}{L}$
44	Young's modulus	$E = \frac{\text{stress}}{\text{strain}}$
45	capacitors	time constant: $\tau = RC$
46	universal gravitational constant	$G = 6.67 \times 10^{-11} \text{ N m}^2\text{kg}^{-2}$
47	mass of Earth	$M_E = 5.98 \times 10^{24} \text{ kg}$
48	radius of Earth	$R_E = 6.37 \times 10^6 \text{ m}$
49	mass of the electron	$m_e = 9.1 \times 10^{-31} \text{ kg}$
50	charge on the electron	$e = -1.6 \times 10^{-19} \text{ C}$
51	speed of light	$c = 3.0 \times 10^8 \text{ m s}^{-1}$

### Prefixes / units

p = pico =  $10^{-12}$

n = nano =  $10^{-9}$

$\mu$  = micro =  $10^{-6}$

m = milli =  $10^{-3}$

k = kilo =  $10^3$

M = mega =  $10^6$

G = giga =  $10^9$

t = tonne =  $10^3 \text{ kg}$

End of Booklet

Looking for solutions? Visit [www.engageeducation.org.au/practice-exams](http://www.engageeducation.org.au/practice-exams)

To enrol in one of our Physics lectures head to: <http://engageeducation.org.au/lectures>