

Trial Examination 2014

VCE Physics Units 3&4

Written Examination

Question and Answer Booklet

Reading time: 15 minutes
Writing time: 2 hours 30 minutes

Student's Name: _____

Teacher's Name: _____

Structure of Booklet

Section	Number of questions	Number of questions to be answered		Number of marks
A Core studies	22	22		128
	Number of questions	Number of detailed studies to be answered	Number of questions to be answered	Number of marks
B Detailed studies	11	1	11	22
				Total 150

Students are permitted to bring into the examination room: pens, pencils, highlighters, erasers, sharpeners, rulers, up to two pages (one A4 sheet) of pre-written notes (typed or handwritten) and one scientific calculator.

Students are NOT permitted to bring into the examination room: blank pieces of paper and/or white out liquid/tape.

Materials supplied

Question and answer booklet of 56 pages with a detachable data sheet in the centrefold.

Answer sheet for multiple-choice questions.

Instructions

Detach the data sheet from the centre of this booklet during reading time.

Please ensure that you write your **name** and your **teacher's name** in the space provided on this booklet and on the answer sheet for multiple-choice questions.

Unless otherwise indicated, the diagrams in this book are **not** drawn to scale.

All written responses must be in English.

Students are NOT permitted to bring mobile phones and/or any other unauthorised electronic devices into the examination room.

Students are advised that this is a trial examination only and cannot in any way guarantee the content or the format of the 2014 VCE Physics Units 3&4 Written Examination.

Neap Trial Exams are licensed to be photocopied or placed on the school intranet and used only within the confines of the school purchasing them, for the purpose of examining that school's students only. They may not be otherwise reproduced or distributed. The copyright of Neap Trial Exams remains with Neap. No Neap Trial Exam or any part thereof is to be issued or passed on by any person to any party inclusive of other schools, non-practising teachers, coaching colleges, tutors, parents, students, publishing agencies or websites without the express written consent of Neap.

Table of Contents**SECTION A**

Areas of study	Page
Motion in one and two dimensions	3
Electronics and photonics	13
Electric power	18
Interactions of light and matter	26

SECTION B

Detailed study	Page
Detailed study 1: Einstein's special relativity	32
Detailed study 2: Materials and their use in structures	36
Detailed study 3: Further electronics	41
Detailed study 4: Synchrotron and its applications	45
Detailed study 5: Photonics	49
Detailed study 6: Sound	53

SECTION A – CORE STUDIES**Instructions for Section A**

Answer **all** questions in this section in the spaces provided. Write using black or blue pen.

Where an answer box has a unit printed in it, give your answer in that unit.

You should take the value of g to be 10 m s^{-2} .

Where answer boxes are provided, write your final answer in the box.

In questions worth more than 1 mark, appropriate working should be shown.

Unless otherwise indicated, diagrams are not to scale.

Area of study – Motion in one and two dimensions**Question 1 (10 marks)**

A dolphin of mass 80 kg projects out of the water as shown in Figure 1 below. The dolphin leaves the water at a speed of 12 m s^{-1} and at an angle of 60° to the horizontal. Assume the trajectory is parabolic and that air resistance is negligible.

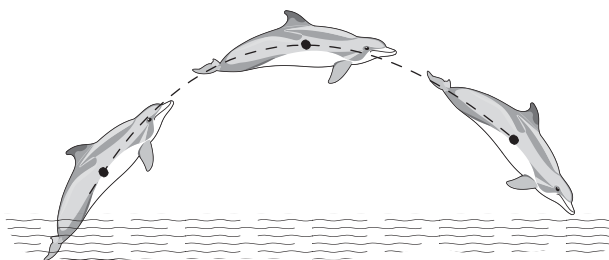
**Figure 1**

- a. Calculate the vertical component of the dolphin's velocity. 1 mark

m s^{-1}

- b. Calculate how long the dolphin is in the air. 2 marks

s

- c. Calculate the maximum height that the dolphin reaches. 2 marks

- d. What is the magnitude of the acceleration of the dolphin when it is at its maximum height? 1 mark

- e. Calculate the kinetic energy of the dolphin when it is at its maximum height. 2 mark

- f. Calculate the range of the dolphin's trajectory. 2 marks

Question 2 (6 marks)

Two trucks are travelling towards each other as shown in Figure 2. Each truck is travelling at a speed of 15 m s^{-1} . Truck A is travelling to the right, is unloaded and has a mass of 5 tonnes, whilst truck B is travelling to the left, is fully loaded and has a mass of 10 tonnes.

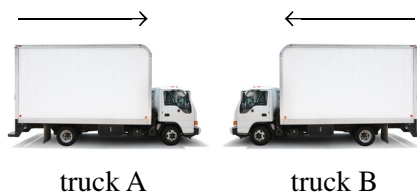
**Figure 2**

Instead of watching the road, both drivers were looking at their mobile phones and the two trucks collided head-on. After the collision both trucks were joined together.

- a. Calculate the common speed and direction of the two trucks when they are joined together after the collision. 2 marks

m s^{-1}	RIGHT or LEFT (circle one)
-------------------	----------------------------

- b. Calculate the amount of kinetic energy lost in this collision. 2 marks

MJ

- c. Explain what happens to the lost kinetic energy. 2 marks

Question 3 (3 marks)

Two blocks, A and B, are being pushed on a frictionless surface by a force of 30 N to the right, as shown in Figure 3. Block A has a mass of 2.0 kg whilst block B has a mass of 4.0 kg.

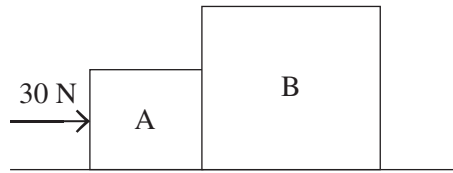
**Figure 3**

- a. Calculate the acceleration of the combined system of blocks A and B.

1 mark

- b. Calculate the magnitude of the force that block B exerts on block A.

2 marks

Question 4 (3 marks)

A traffic engineer has to determine the maximum speed that a car can take an 80 m radius bend on a horizontal mountain road when the road is wet. Figure 4 shows a schematic top view of the situation.

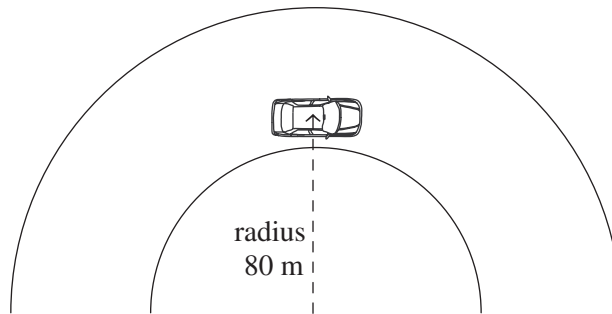
**Figure 4**

- a. Calculate the maximum speed a 1400 kg car can take the bend at when there is a maximum friction between the tyres and the road of 2800 N. 2 marks

m s^{-1}

- b. On Figure 4, draw the direction of the centripetal force (F_c) acting on the car. 1 mark

Question 5 (3 marks)

A 1 kg mass is set spinning vertically at a constant speed of 5 m s^{-1} on a light rod, as shown in Figure 5. The length of the rod is 0.5 m.

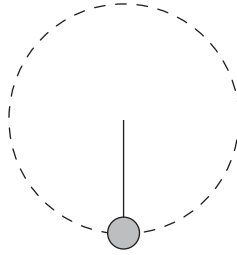
**Figure 5**

- a. Calculate the tension in the rod when the mass is at the bottom of the vertical circle as shown in Figure 5.

2 marks

- b. Calculate the work done by the tension force in the rod as the mass completes one revolution.

1 mark

Question 6 (3 marks)

Figure 6 shows the force versus time graph for a 60 g tennis ball when it is hit by a tennis racquet whilst a player is serving.

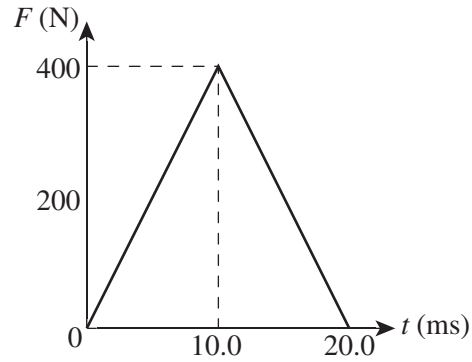

Figure 6

Calculate the speed (in km h^{-1}) at which the tennis ball is served if the tennis ball is stationary when it is hit by the tennis racquet.

Question 7 (4 marks)

Figure 7 shows the force versus extension graph for a bungee jump elastic cord.

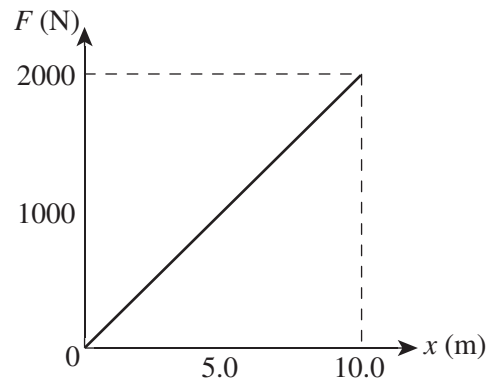

Figure 7

- a. Calculate the spring constant for the bungee jump cord (include a unit in your answer). 2 marks

A bungee jumper stretches the elastic cord a distance of 8.6 m beyond its natural length before coming to rest.

- b. Calculate the amount of energy stored in the stretched bungee cord. 2 marks

Question 8 (3 marks)

Figure 8 shows the trajectory for an aeroplane used in training astronauts. At the top of the flight the plane is flying at an altitude of 10 000 m. From time $t = 20$ s to $t = 45$ s, the trajectory of the aeroplane is the arc of a circle and the trainee astronauts experience zero gravity near the top of the arc.

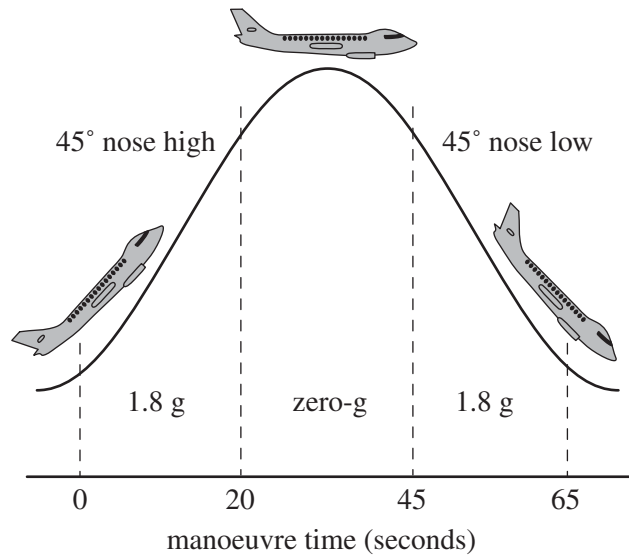
**Figure 8**

Explain how the terms 'weight', 'weightlessness' and 'apparent weightlessness' do or do not apply to the trainee astronauts between $t = 20$ s to $t = 45$ s near the top of the arc.

Question 9 (5 marks)

India launched its Indian Regional Navigation Satellite System (IRNSS-1B) on 4 April 2014. This 1432 kg satellite has been put into a geosynchronous orbit and will provide navigation, tracking and mapping services.

- a. Calculate the radius of the orbit of IRNSS-1B. You must show all your working. 3 marks

- b. Calculate the force acting on IRNSS-1B in its geosynchronous orbit due to Earth's gravity. (Show your answer to three significant figures.) 2 marks

- b. Calculate the power dissipated in the temperature-dependent resistor when the temperature is 25°C and V_{OUT} is equal to 4.0 V . 2 marks

W

The circuit is now modified so that it also includes an LED, as shown in Figure 11.

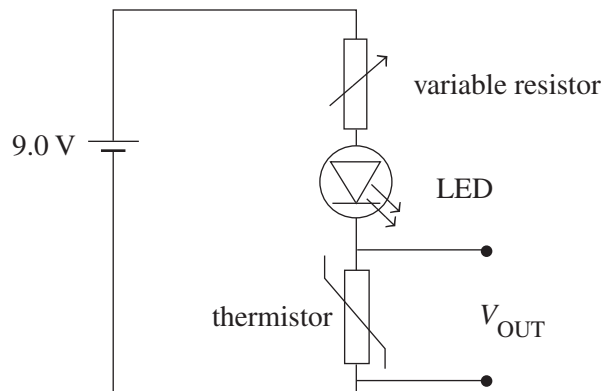

Figure 11

The characteristic curve for the LED is shown in Figure 12.

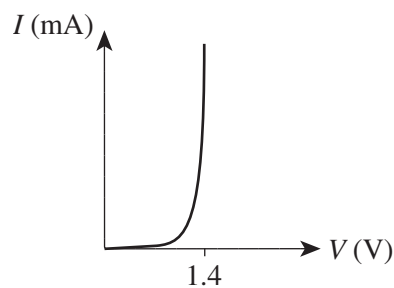

Figure 12

- c. With the LED added to the circuit, should the resistance of the variable resistor be increased, decreased or remain unchanged in order for the TDR to maintain power output at 25°C as in the original circuit (shown in Figure 9)? Use calculations to support your answer. 3 marks

- d. Explain what will happen to V_{OUT} as the temperature drops below 25°C , and hence describe in detail an application that this circuit could be used for. 3 marks

One of the circuit components in Figure 11 can be described as an ‘opto-electrical device’.

- e. Identify which component is an opto-electrical device and explain what this means in the context of this component. 2 marks

Question 11 (2 marks)

A student wishes to construct a circuit with a total resistance of $80\ \Omega$. She only has five resistors, each with a value of $30\ \Omega$.

Draw a circuit diagram to show how she could combine some or all of the five $30\ \Omega$ resistors to provide a total resistance of $80\ \Omega$.

Question 12 (5 marks)

A single-stage amplifier is used to amplify the signal shown in Figure 13(a), with the output of the amplifier shown in Figure 13(b).

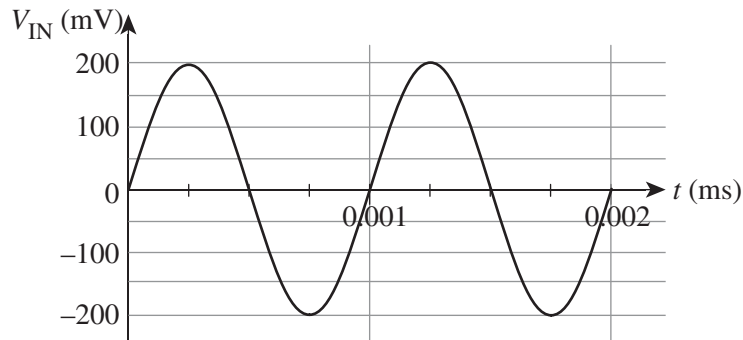

Figure 13(a)

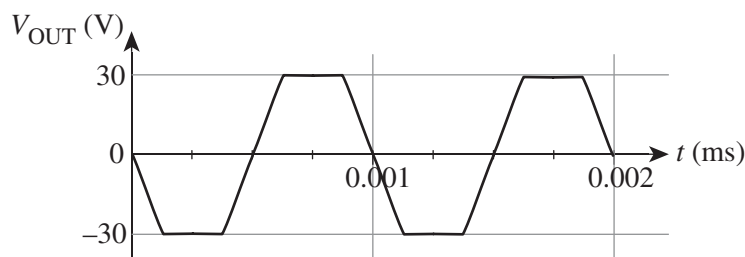
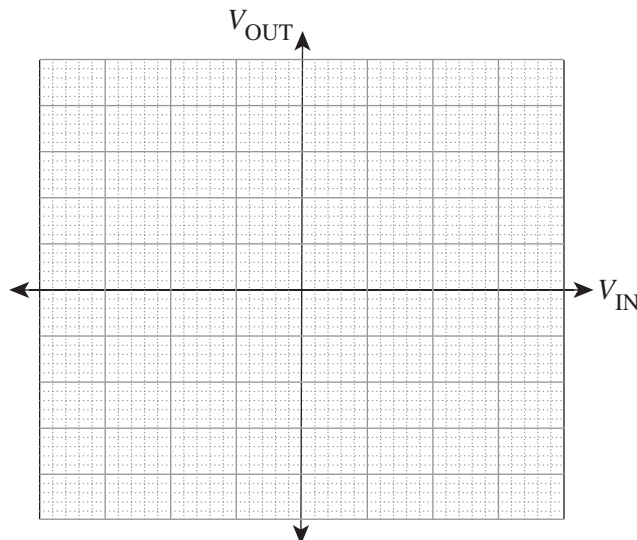

Figure 13(b)

- a. What is the magnitude of the gain of this amplifier? 2 marks

- b. Use the information provided in Figures 13(a) and 13(b) to draw a graph of V_{OUT} versus V_{IN} for this amplifier. Use an appropriate scale and units on each axis. 3 marks



Question 13 (4 marks)

A system is designed to transmit sound waves via an amplitude-modulated light wave from the source to a receiver, as shown in the schematic diagram in Figure 14.

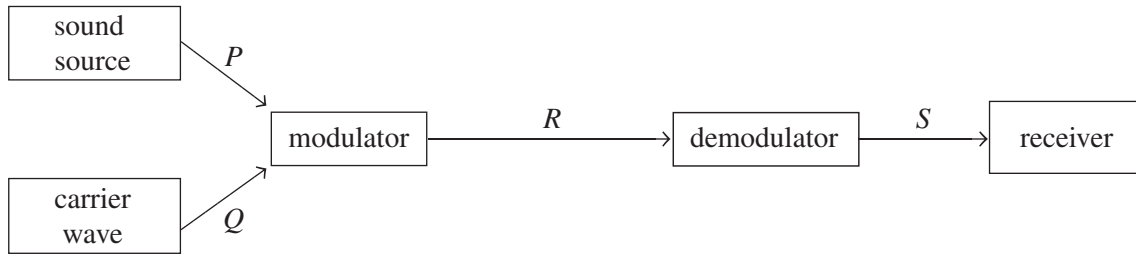
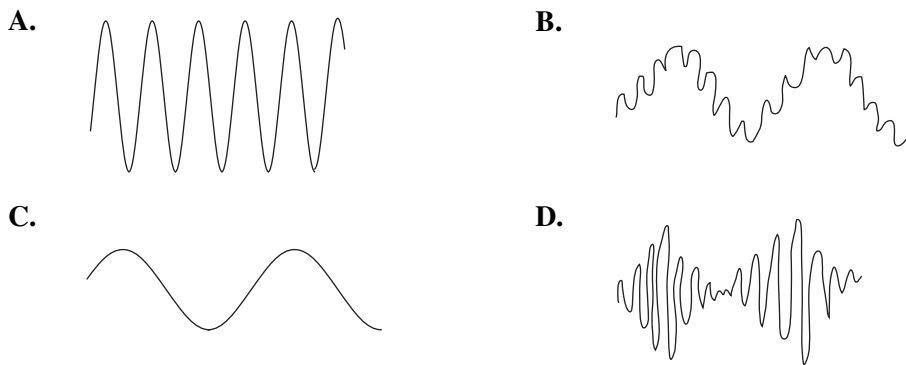

Figure 14

Four stages in the transmission process are identified in Figure 14: *P*, *Q*, *R* and *S*.

Four possible wave forms are shown below.



For each of the stages *P–S*, identify which of the four possible waveforms (**A–D**) would be the most likely signal at that point. Note that you may use a waveform for more than one answer. 4 marks

Position	<i>P</i>	<i>Q</i>	<i>R</i>	<i>S</i>
Waveform (A , B , C or D)				

Area of study – Electric power

Question 14 (7 marks)

A solenoid is constructed as shown in Figure 15 and connected to a variable DC power supply. A bar magnet is initially stationary and close to the end of the solenoid. *X* is a point to the right of the solenoid, as shown.

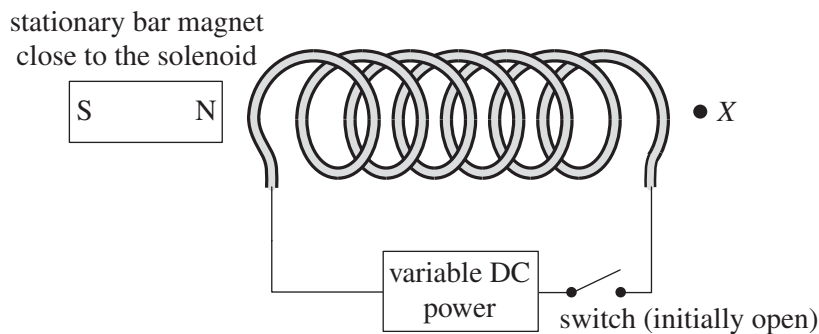

Figure 15

When the switch is closed, a repulsive force is exerted on the bar magnet and it moves to the left.

- a. Use arrows to draw the direction of conventional current flowing through the solenoid on Figure 15. Explain your answer. 3 marks

The bar magnet is now removed from the vicinity of the coil. Figure 16 shows the view looking into the solenoid coil from point *X*, which is shown at the right-hand end of the solenoid in Figure 15.

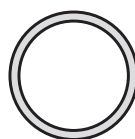

Figure 16

- b. Which of the following correctly shows both the field direction inside the coil due to the current flowing through it, and the current direction around the coil when viewed from point *X*? 1 mark

<p>A.</p>	<p>B.</p>
<p>C.</p>	<p>D.</p>

The variable power supply is now replaced with a galvanometer, as shown in Figure 17. The galvanometer indicates the direction of conventional current which passes through it, either to the left or the right.

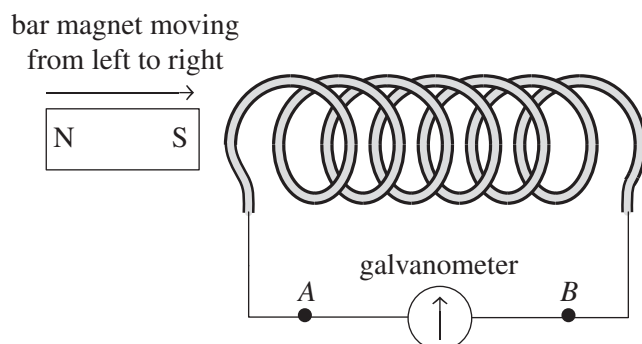

Figure 17

The north pole of the permanent bar magnet is now moved towards the left-hand end of the solenoid at a constant speed.

- c. Will current flow through the galvanometer in the direction from *A* to *B* or from *B* to *A*?
Explain your answer.

3 marks

current direction:

Question 15 (16 marks)

Two students design and construct a model of a DC electric motor (Figure 18) by placing a rectangular coil *WXYZ* between two magnetic poles and connecting the coil to a DC power supply. The switch is initially open.

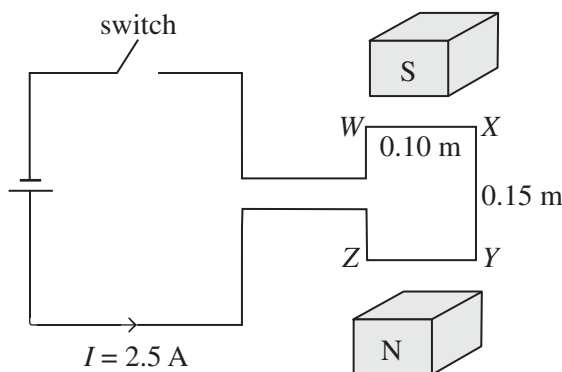

Figure 18

When the switch is closed, the current flowing through the coil *WXYZ*, which has 30 turns, is equal to 2.5 A. The magnetic field strength between the north and south poles is equal to 0.35 T. The length of side *XY* is 0.15 m and the length of side *WX* is 0.10 m.

- a. Calculate the magnitude of the force on side *YZ* when the switch is closed and the coil is in the orientation shown in Figure 18. 2 marks

N

- b. Draw an arrow on Figure 18 to show the direction of the force on side *XY* when the switch is closed and the coil is in the orientation shown in the diagram. If there is no force, write 'NF' clearly next to side *XY*. 1 mark

- c. The students find that when they close the switch, the motor does not operate as expected when constructed as shown in Figure 18. Explain what will happen when the switch is closed, and the reason that this occurs. 3 marks

- d. In order to rectify the problem with the motor, the students should include which of the following in the circuit? 1 mark
- a slip-ring commutator
 - a split-ring commutator
 - a slip-ring transformer
 - a split-ring alternator

The students now use the same rectangular coil with side lengths $XY = 0.15$ m and $WX = 0.10$ m, and magnetic field of strength 0.35 T shown in Figure 18 to investigate electromagnetic induction.

The coil $WXYZ$ (consisting of 30 turns) is connected to a resistor, R , as shown in Figure 19, and moved from left to right through the magnetic field. Three positions are shown: position A, position B and position C.

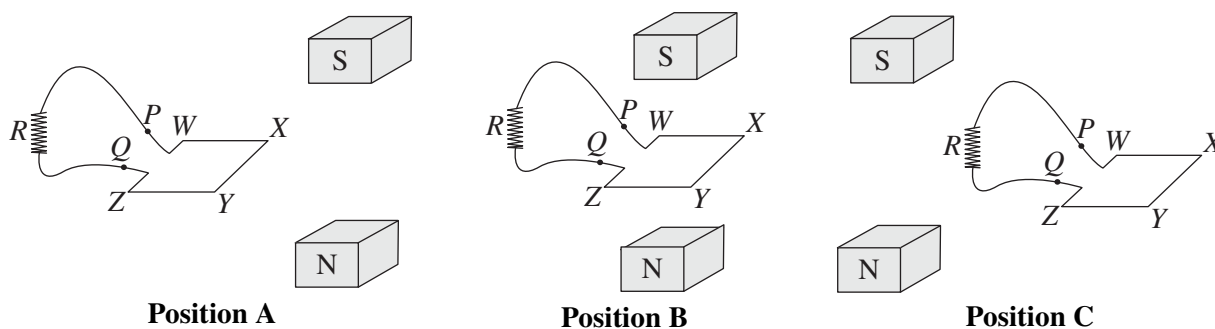

Figure 19

- e. When the coil is located in position B, calculate the flux passing through the coil $WXYZ$. 2 marks

- f. As the coil moves from position A to position B at a constant speed, an average EMF of 0.15 V is induced between points P and Q .
Calculate the time it takes for the coil to move from position A to position B. 2 marks

- g.** The resistor R is connected to the coil $WXYZ$ and a current flows through the resistor when an EMF is induced.

On the copy of the resistor and coil diagram below, use an arrow to show the direction that conventional current will flow through the resistor R as the coil moves from position B to position C. Explain your reasoning.

3 marks

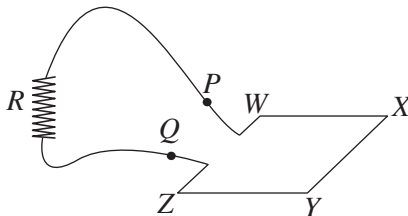

- h.** The time taken for the coil to move from position B to position C is four times as long as the time for the coil to move from position A to position B.

The power dissipated in the coil as it moves from position A to B will be

2 marks

- A. $\frac{1}{16}$ of the power dissipated as the coil moves from position B to position C.
- B. $\frac{1}{4}$ of the power dissipated as the coil moves from position B to position C.
- C. 4 times the power dissipated as the coil moves from position B to position C.
- D. 16 times the power dissipated as the coil moves from position B to position C.

Question 16 (13 marks)

A large diesel-powered AC generator is permanently mounted on a truck to provide emergency power to a water pump used by firefighters. The generator produces a sinusoidal voltage as shown in Figure 20.

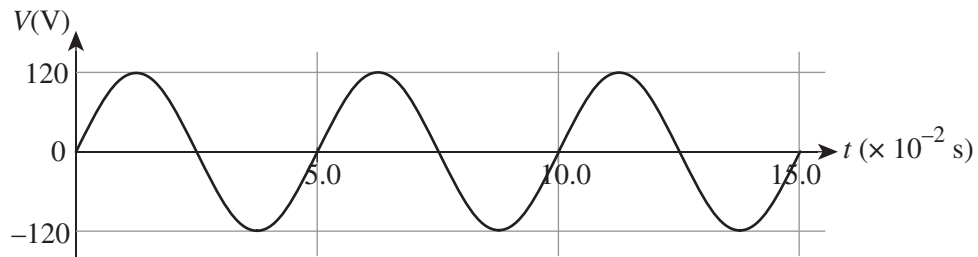
**Figure 20**

- a. Calculate the frequency of rotation of the generator coil.

2 marks

Hz

- b. The firefighters also have a bank of DC batteries they can use in case the generator fails. What is the total voltage of the battery bank required to provide the same amount of power to the water pump as the diesel generator?

2 marks

V

At a certain location the firefighters are unable to drive a similar generator truck close to the point where they need to operate the water pump. Instead, they use two long wires to connect the generator to the water pump over a distance of 200 m, and include both a step-up and a step-down transformer in the arrangement. This is shown schematically in Figure 21. (Note: Diagram is not to scale.)

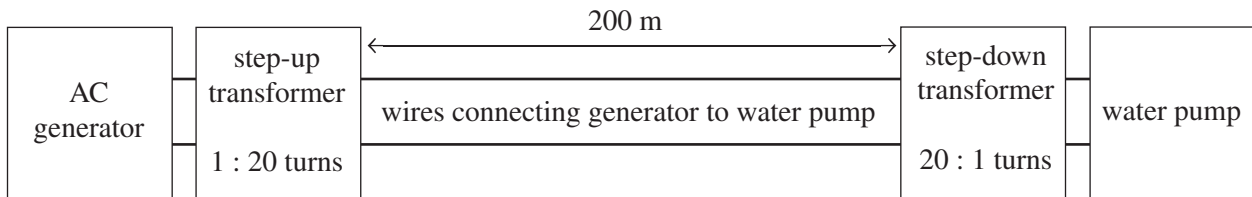

Figure 21

The resistance of the connecting wires is $5.0 \Omega \text{ m}^{-1}$ and this generator is now producing 500 W and 120 V RMS. The turns ratio for the step-up transformer is 1 : 20 and the turns ratio for the step-down transformer is 20 : 1.

- c. Calculate the power loss in the system shown in Figure 21.

3 marks

W

- d. Calculate the voltage supplied to the water pump with the arrangement shown in Figure 21.

3 marks

V

Fred, one of the firefighters, suggests that the system shown in Figure 21 would operate more effectively if the generator was replaced with a bank of batteries, as shown in Figure 22.

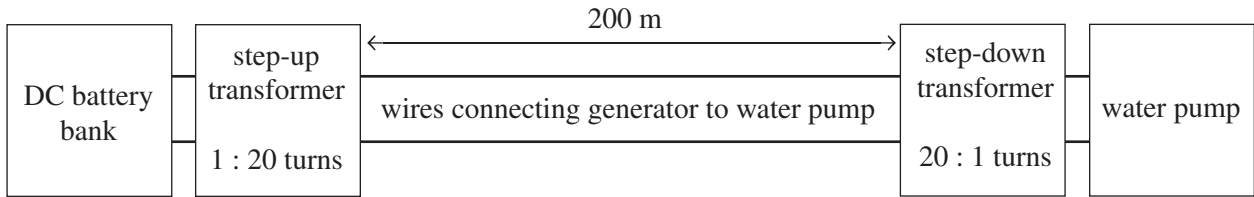

Figure 22

- e. Would the arrangement shown in Figure 22 allow the pump to operate effectively?
Explain your answer.

3 marks

Area of study 2 – Interactions of light and matter

Question 17 (7 marks)

Students set up an experiment to investigate interference effects with light. They use a green laser of wavelength 532 nm and shine it on two slits, S_1 and S_2 . Point P_1 represents the first dark band out from the centre of the pattern. The distance from the slits to the screen is L .

Figure 23 shows the sketch the students put in their practical report.

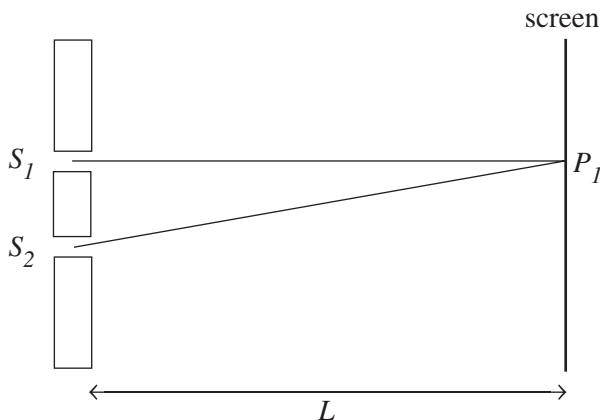

Figure 23

- a. Calculate the path difference $S_2P_1 - S_1P_1$. Show your working.

2 marks

nm

The distance L is now decreased.

- b. Describe the effect of this change on the spacing of the interference pattern observed on the screen.

1 mark

The screen is now put back to its original position and the green laser is replaced with a red laser of wavelength 600 nm.

- c. Describe the effect of this change on the spacing of the interference pattern observed on the screen.

1 mark

d. Explain how this experiment supports the wave nature of light.

3 marks

Question 18 (2 marks)

In 1913 the Danish physicist Niels Bohr postulated the concept of quantised energy states of an atom and used this theory to successfully explain the spectral emission lines for the hydrogen atom.

Describe how Louis de Broglie's concept of standing waves (proposed in 1924) explains the quantised energy states of an atom. Include a diagram in your answer.

Question 19 (7 marks)

The maximum kinetic energy of photoelectrons emitted from a metal (A) as a function of the frequency of the incident light is shown in Figure 24.

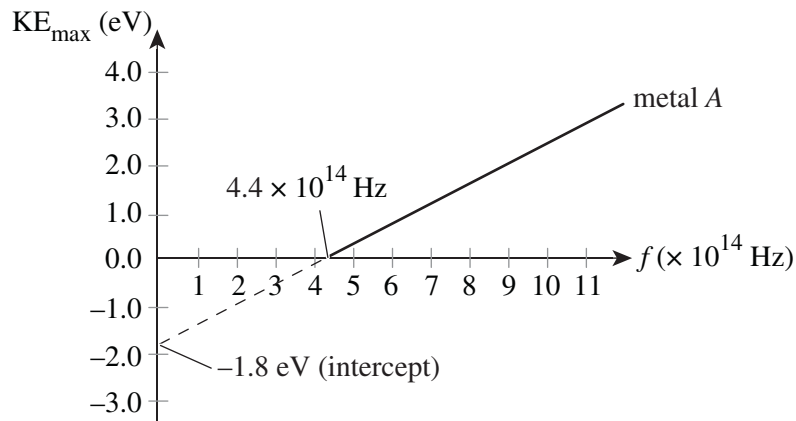
**Figure 24**

- a. Using the information in Figure 24, calculate Planck's constant to three significant figures. Include a unit in your answer. Show your working.

3 marks

An electron is ejected from the surface of the metal with a kinetic energy of 3.0 eV.

- b. Assuming all the energy has come from the incident photon, calculate to three significant figures the wavelength of that photon. Show your working.

2 marks

To study the photoelectric effect in more detail, another metal, *B*, with a work function of 3.0 eV is also irradiated with light over the same frequency range as the original metal shown in Figure 24.

- c. Draw on the replica of Figure 24 below the maximum kinetic energy of photoelectrons emitted from metal *B* as a function of the frequency of the incident light. Label your drawing as metal *B*. 2 marks

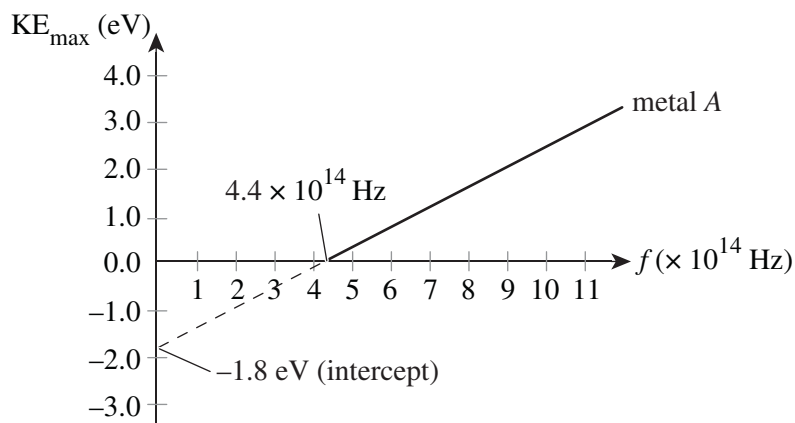

Question 20 (4 marks)

Figure 25 shows part of the energy-level diagram for sodium, with five distinct energy levels and the ionisation level.

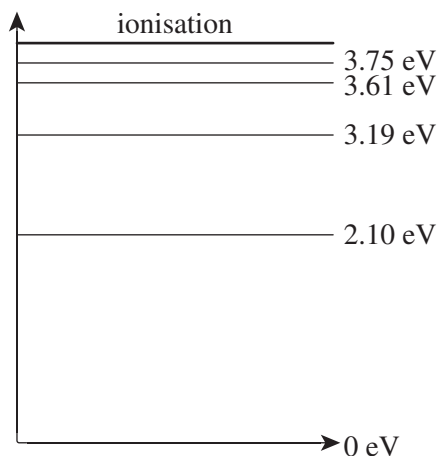

Figure 25

- a. Using an arrow, draw clearly on Figure 25 the transition involved with the emission of a 1.51 eV photon. 2 marks
- b. Ignoring the ionisation level, calculate the longest wavelength photon that is emitted by sodium using the other five energy levels shown in Figure 25. 2 marks

m

Question 21 (6 marks)

Physicists conduct an experiment to investigate de Broglie's model concerning the wave nature of matter. Electrons are accelerated using the new Monash University synchrotron until they reach a speed of $6.8 \times 10^6 \text{ m s}^{-1}$. The accelerated electrons are then targeted at a specimen of powdered aluminium foil that has an atomic spacing of $1.0 \times 10^{-10} \text{ m}$. The mass of an electron is $9.11 \times 10^{-31} \text{ kg}$.

- a. Calculate the de Broglie wavelength of the electrons. 2 marks

m

- b. Explain whether or not this experiment will demonstrate the wave nature of the electrons. Justify your answer. 2 marks

Another physicist wants to use neutrons of the same kinetic energy as the electrons to investigate the wave nature of neutrons on the powdered aluminium sample. The mass of a neutron is $1.67 \times 10^{-27} \text{ kg}$.

- c. Explain whether or not this experiment will demonstrate the wave nature of the neutrons. Justify your answer. 2 marks

Question 22 (2 marks)

Jian and Nia are discussing diffraction patterns. They note that when a particular type of electron beam is passed through a crystal it produces a diffraction pattern as shown in Figure 26. They also note that the same type of diffraction pattern is produced with a particular type of X-ray beam when it is passed through the same crystal.



Figure 26

Jian believes that the X-ray beam has the same velocity and energy as the electron beam, while Nia believes that the X-ray beam has the same wavelength and momentum as the electron beam.

Who has the correct explanation – Jian or Nia? Justify your answer.

END OF SECTION A

SECTION B**Instructions for Section B**

Choose **one** Detailed study and answer **all** questions within that Detailed study in pencil on the answer sheet provided for multiple-choice questions.

Show the Detailed study you are answering by shading the matching box on your multiple-choice answer sheet and writing the name of the Detailed study in the box provided.

Choose the response that is **correct** for the question.

A correct answer scores 2, an incorrect answer scores 0.

Marks will **not** be deducted for incorrect answers.

No marks will be given if more than one answer is completed for any question.

You should take the value of g to be 10 m s^{-2} .

Detailed Study 1 – Einstein’s special relativity

Use the following information to answer Questions 1 and 2.

A spherical spaceship of radius R_0 speeds through our solar system at $0.95c$ as shown in Figure 1. An observer is at point O .

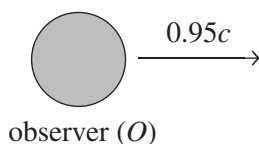

Figure 1





Question 1

The radius of the spherical space ship in the direction of movement in the reference frame of the solar system is closest to

- A. $0.22 R_0$
- B. $0.31 R_0$
- C. R_0
- D. $3.2 R_0$

Question 2

To the observer (O), the spherical spaceship in the reference frame of the solar system would look closest to

- A. 
- B. 
- C. 
- D. 

Use the following information to answer Questions 3 and 4.

A high-energy particle physicist is examining high-energy muons in a linear accelerator. One such muon is travelling at $0.995c$ and has a half-life of 20 ns.

Question 3

The particles half-life in its reference frame is closest to

- A. 1.0 ns
- B. 2.0 ns
- C. 10 ns
- D. 200 ns

Question 4

In a 400 m long section of the linear accelerator, as measured in the Earth's reference frame, the particle is travelling at a constant speed of $0.995c$.

This section of the linear accelerator as measured in the particle's reference frame is

- A. 0.4 m
- B. 4.0 m
- C. 40.0 m
- D. 4000 m

Use the following information to answer Questions 5 and 6.

A helium ion is accelerated in a synchrotron from rest using 800 MeV of energy. The rest mass of a helium ion is 6.6×10^{-27} kg.

Question 5

800 MeV of energy is equivalent to

- A. 1.3×10^{-16} J
- B. 1.3×10^{-10} J
- C. 800 J
- D. 800 MJ

Question 6

The mass increase of the helium ion after it has been accelerated is closest to

- A. 1.4×10^{-27} kg
- B. 1.4×10^{-28} kg
- C. $6.6 \mu\text{kg}$
- D. $8.0 \mu\text{kg}$

Use the following information to answer Questions 7 and 8.

In 1877 Michelson and Morley undertook a number of experiments involving two light beams that travelled through a beam splitter onto mirrors, as shown schematically in Figure 2. The distance of each mirror from the beam splitter was 11.0 m (L).

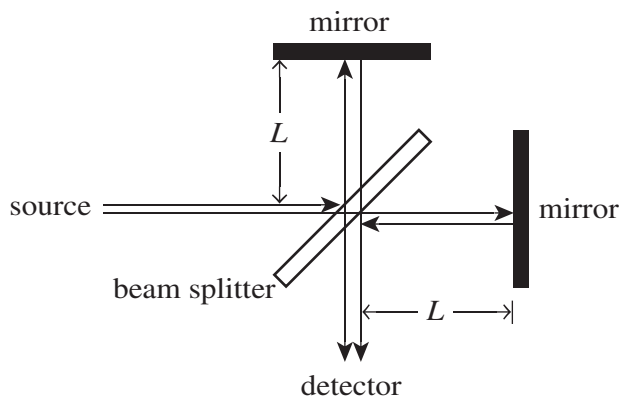

Figure 2

Question 7

The aim of Michelson and Morley's experiment was to

- A. make a very accurate measurement of the speed of light.
- B. demonstrate that light showed interference effects.
- C. prove that light was an electromagnetic wave.
- D. measure the speed of the Earth through the ether.

Question 8

At their detector Michelson and Morley observed

- A. a phase shift in the interference pattern created by the light beams returning from the two journeys.
- B. no phase shift in the interference pattern created by the light beams returning from the two journeys.
- C. relativistic length-contraction effects.
- D. relativistic time-dilation effects.

Question 9

Positron emission tomography (PET) involves the production of two high-energy gamma rays that shoot off in opposite directions, taking equal amounts of energy. The gamma rays are created when an antiparticle (the positron) and an electron collide. The mass of both the electron and the positron is the same: 9.11×10^{-31} kg.

If both the positron and electron are considered to be stationary when they collide, the energy of one of the gamma rays produced in a PET scanner is

- A. 9.11×10^{-31} J
- B. 1.8×10^{-30} J
- C. 8.2×10^{-14} J
- D. 1.6×10^{-13} J

Question 10

Which one of the following statements best explains why it is impossible to accelerate protons so that they travel at the speed of light?

- A. As the proton increases its speed its rest mass (m_0) approaches an infinite value.
- B. The kinetic energy of the proton given by $KE = (\gamma - 1) m_0 c^2$ approaches an infinite value.
- C. The speed of a proton is given by $\frac{\text{length travelled}}{\text{time}}$ and as time approaches zero, the speed approaches an infinite value.
- D. The protons disintegrate into other subatomic particles as they approach the speed of light.

Question 11

Which one of the following correctly describes factors that affect the speed of light?

- A. the speed of the light-emitting source
- B. the electrical properties of the medium through which the light travels
- C. the speed which an observer of the light is travelling at
- D. none of the above – the speed of light is always constant

SECTION B**Instructions for Section B**

Choose **one** Detailed study and answer **all** questions within that Detailed study in pencil on the answer sheet provided for multiple-choice questions.

Show the Detailed study you are answering by shading the matching box on your multiple-choice answer sheet and writing the name of the Detailed study in the box provided.

Choose the response that is **correct** for the question.

A correct answer scores 2, an incorrect answer scores 0.

Marks will **not** be deducted for incorrect answers.

No marks will be given if more than one answer is completed for any question.

You should take the value of g to be 10 m s^{-2} .

Detailed Study 2 – Materials and their use in structures

Use the following information to answer Questions 1–6.

A solid, narrow window awning of mass 20 kg is supported by a single strut as shown in Figure 1. The awning makes an angle of 50° with the wall, and the strut also makes an angle of 50° with the wall. The length of the awning is 1.2 m and the length of the strut is 0.3 m. The point marked X is the point where the awning is attached to the wall above the window.

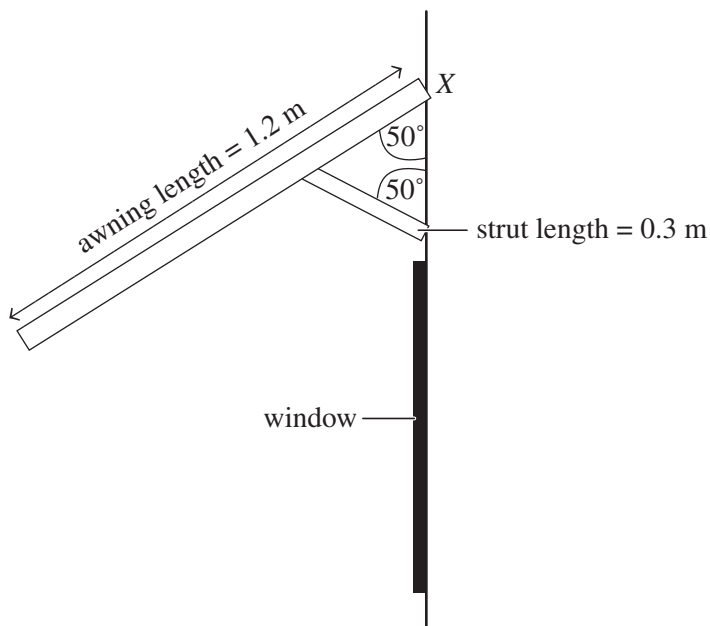

Figure 1

Question 1

The torque exerted around the point marked X by the awning is equal to

- A. 9.2 Nm
- B. 77 Nm
- C. 92 Nm
- D. 120 Nm

Question 2

The force exerted on the awning by the strut is equal to

- A. 53 N
- B. 93 N
- C. 306 N
- D. 311 N

Question 3

Which of the following diagrams shows the approximate direction of the force F exerted by the wall on the awning at point X ?

A.

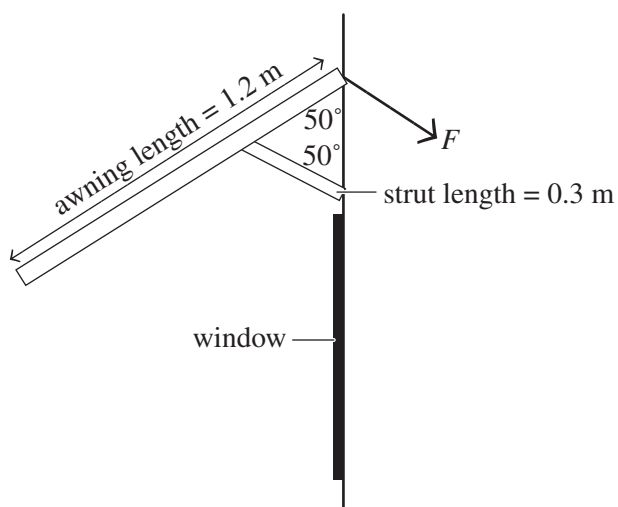

B.

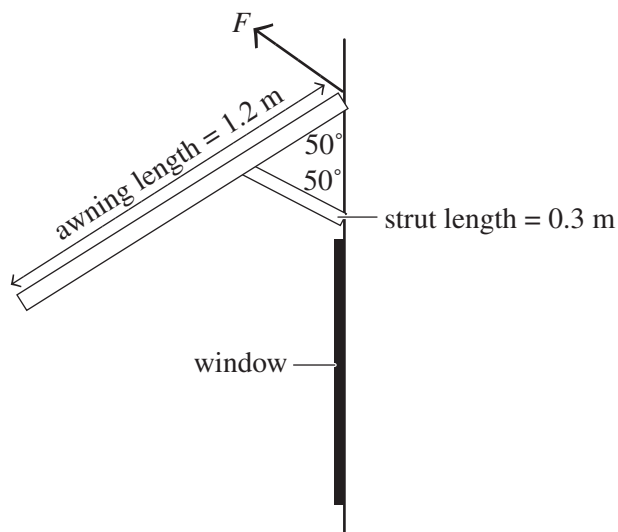

C.

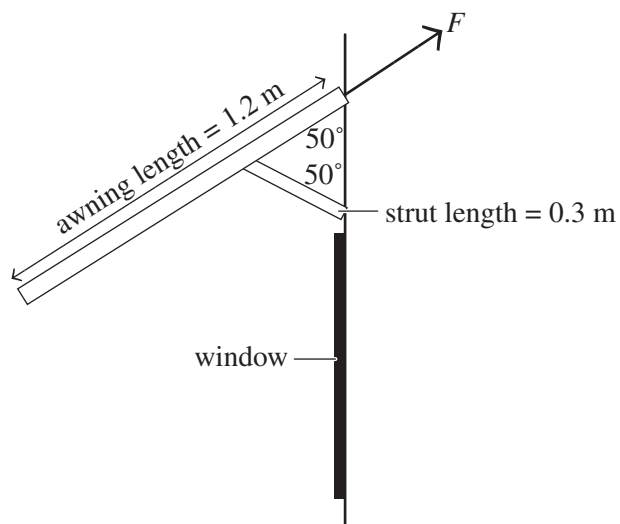

D.

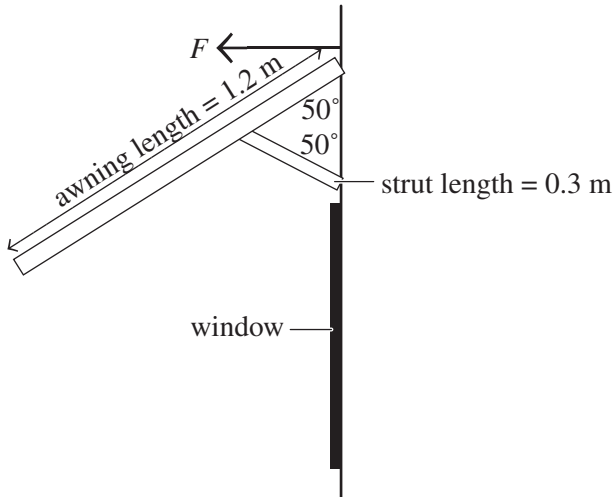

An enlarged diagram of the awning and strut in Figure 2 shows the top and bottom sections of the awning structure.

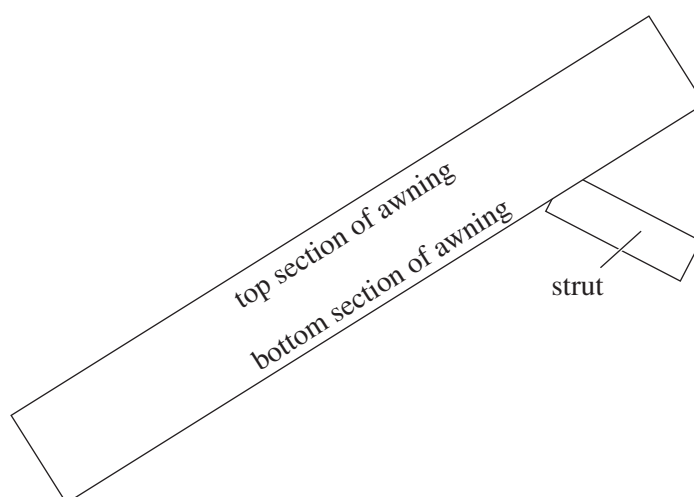

Figure 2

Question 4

Which of the following best describes the forces acting within the top and bottom sections of the awning and in the strut?

	Forces in top section of awning	Forces in bottom section of awning	Forces in strut
A.	compression	tension	compression
B.	tension	compression	compression
C.	compression	tension	tension
D.	tension	compression	tension

A similar strut on another window exerts a force of 200 N on the awning. The strut has a square cross-section with side length 4.0 cm.

Question 5

The stress in the strut is equal to

- A. $5.0 \times 10^3 \text{ N m}^{-2}$
- B. $4.0 \times 10^4 \text{ N m}^{-2}$
- C. $1.3 \times 10^5 \text{ N m}^{-2}$
- D. $1.3 \times 10^6 \text{ N m}^{-2}$

The strut is constructed of timber with a Young's Modulus of $1.0 \times 10^{10} \text{ N m}^{-2}$ and has an initial length of 0.3 m.

Question 6

When the strut exerts the force of 200 N on the awning its length will change by

- A. $2.0 \times 10^{-8} \text{ m}$
- B. $3.8 \times 10^{-6} \text{ m}$
- C. $1.3 \times 10^{-5} \text{ m}$
- D. $1.5 \times 10^{-3} \text{ m}$

Use the following information to answer Questions 7–11.

The graph in Figure 3 shows the stress–strain relationship for four different materials – W, X, Y and Z – when under compression and tension.

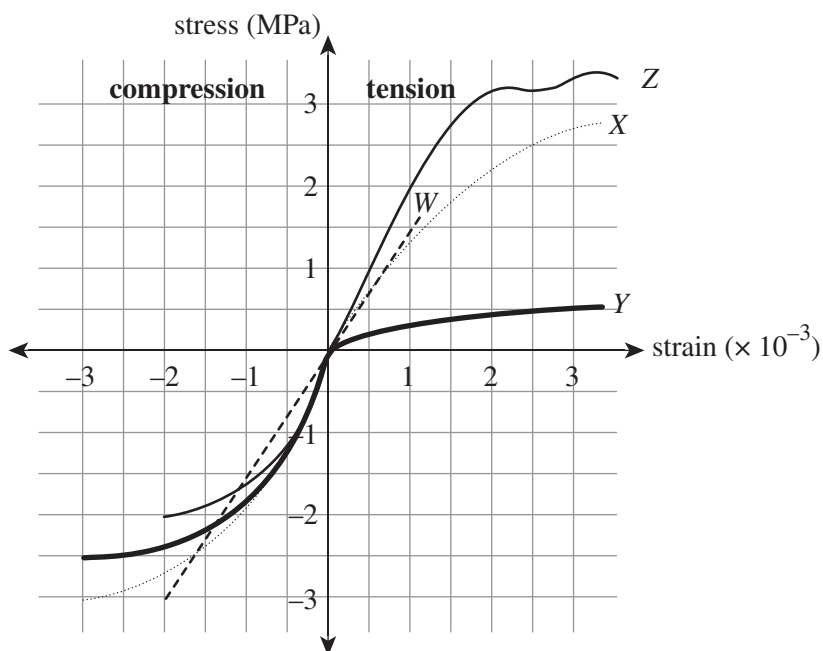

Figure 3

Question 7

Which of the materials is brittle in both tension and compression?

- A. W
- B. X
- C. Y
- D. Z

Question 8

The maximum amount of energy per cubic meter that can be stored by material X when under compression is approximately equal to

- A. $7.0 \times 10^3 \text{ J m}^{-3}$
- B. $1.0 \times 10^4 \text{ J m}^{-3}$
- C. $2.0 \times 10^6 \text{ J m}^{-3}$
- D. $6.7 \times 10^8 \text{ J m}^{-3}$

Question 9

The material most likely to be concrete is

- A. W
- B. X
- C. Y
- D. Z

Question 10

The material which would be most effective to combine with concrete to produce a composite material which is strong in both tension and compression would be

- A. W
- B. X
- C. Y
- D. Z

Question 11

A cylinder of material *W* has a radius of 2.5 cm and a length of 0.6 m.

If a tensile force of 3.0×10^3 N is applied to the cylinder, the energy stored in the cylinder is approximately equal to

- A. 9.0×10^{-1} J
- B. 7.5×10^2 J
- C. 1.5×10^3 J
- D. 1.5×10^6 J

SECTION B**Instructions for Section B**

Choose **one** Detailed study and answer **all** questions within that Detailed study in pencil on the answer sheet provided for multiple-choice questions.

Show the Detailed study you are answering by shading the matching box on your multiple-choice answer sheet and writing the name of the Detailed study in the box provided.

Choose the response that is **correct** for the question.

A correct answer scores 2, an incorrect answer scores 0.

Marks will **not** be deducted for incorrect answers.

No marks will be given if more than one answer is completed for any question.

You should take the value of g to be 10 m s^{-2} .

Detailed study 3 – Further electronics

Use the following information to answer Questions 1 and 2.

Domestic electricity in Australia is supplied as 240 V AC RMS @ 50 Hz.

Question 1

The period T of this AC signal is

- A. 2 ms
- B. 10 ms
- C. 20 ms
- D. 50 ms

Question 2

The peak voltage, V_p , of this AC signal is

- A. 170 V
- B. 240 V
- C. 339 V
- D. 678 V

Use the following information to answer Questions 3 and 4.

A transformer is being used to transform the mains 240 V AC electricity into 24 V AC for a smartphone. The transformer draws 0.1 A from the 240 V mains. Assume the transformer is ideal.

Question 3

The ratio of the number of turns in the primary coil : number of turns in the secondary coil is

- A 240 : 1
- B 10 : 1
- C 1 : 10
- D 1 : 240

Question 4

The current supplied to the smartphone is

- A. 0.01 A
- B. 0.1 A
- C. 1.0 A
- D. 10.0 A

Use the following information to answer Questions 5–8.

Figure 1 shows a half-wave rectification circuit consisting of a diode and a load resistor. $V_{\text{IN}} = 10 \text{ V AC}$ and the load resistance $R = 200 \ \Omega$.

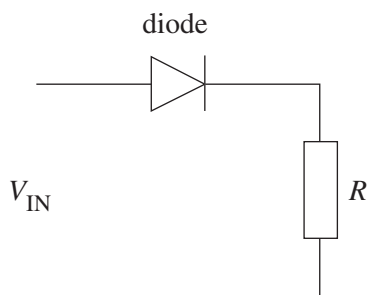

Figure 1

The characteristic graph for the diode is shown in Figure 2.

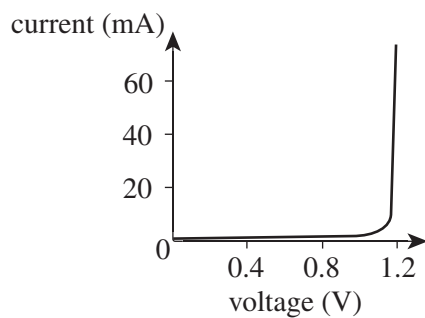

Figure 2

Question 5

The current through the resistor is

- A. 6.0 mA
- B. 44 mA
- C. 50 mA
- D. 88 mA

A capacitor (C) of value $50.0 \mu\text{F}$ is now placed into the circuit as shown in Figure 3.

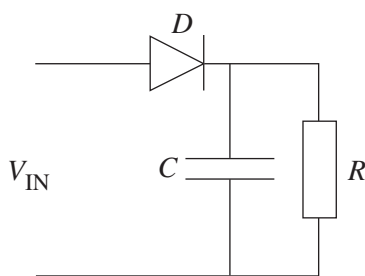
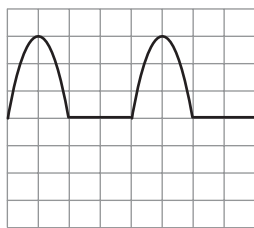

Figure 3

Question 6

Which one of the following graphs best shows the CRO output of the circuit shown in Figure 3 if the CRO leads are placed across the resistor, R ?

A.



B.

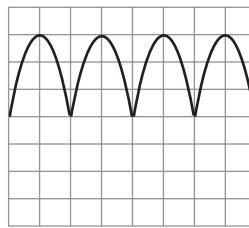

C.

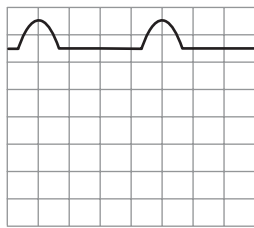

D.

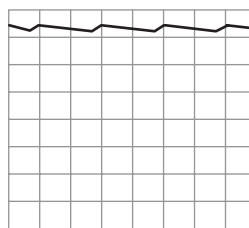

Question 7

The time constant of the RC circuit is

- A. 1 ms
- B. 10 ms
- C. 100 ms
- D. 500 ms

Question 8

The reason for putting the capacitor in the circuit is to

- A. block the negative currents.
- B. limit the current running through the diode.
- C. increase the output voltage.
- D. smooth the output voltage.

Use the following information to answer Questions 9–11.

Figure 4 shows the current–voltage characteristic graph for a 9 V voltage regulator.

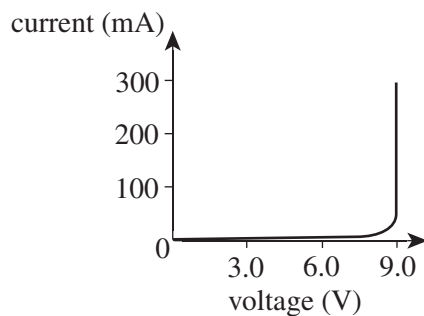

Figure 4

The output current through a resistive load is measured at 180 mA.

Question 9

The value of the resistive load is

- A. 9 Ω
- B. 50 Ω
- C. 180 Ω
- D. 500 Ω

Question 10

The reason for using a voltage regulator in a circuit is that the

- A. resistance is constant for a range of current values.
- B. current output is constant for a range of voltage values.
- C. voltage output is constant for a range of current values.
- D. power output is constant for all values of the current.

Question 11

Which one of the following is **not** true about voltage regulators.

- A. They get very hot when operating.
- B. They need heat sinks to operate reliably.
- C. They shut down if they exceed a certain temperature.
- D. They must have heat sinks made from aluminium.

SECTION B**Instructions for Section B**

Choose **one** Detailed study and answer **all** questions within that Detailed study in pencil on the answer sheet provided for multiple-choice questions.

Show the Detailed study you are answering by shading the matching box on your multiple-choice answer sheet and writing the name of the Detailed study in the box provided.

Choose the response that is **correct** for the question.

A correct answer scores 2, an incorrect answer scores 0.

Marks will **not** be deducted for incorrect answers.

No marks will be given if more than one answer is completed for any question.

You should take the value of g to be 10 m s^{-2} .

Detailed study 4 – Synchrotron and its applications

Use the following information to answer Questions 1–3.

In the electron gun of a synchrotron, an electron is accelerated between parallel plates X and Y , separated by a distance of 0.15 m as shown in Figure 1. The electron's acceleration as it moves between the plates is $8.2 \times 10^{16} \text{ m s}^{-2}$.

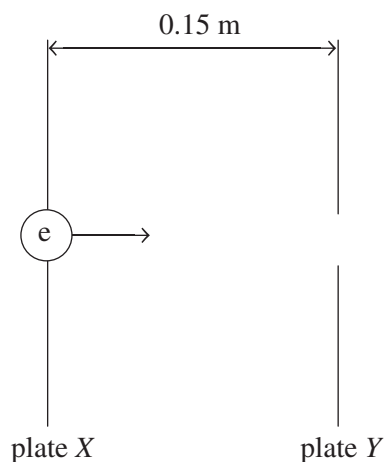

Figure 1

Question 1

The potential difference between plate X and plate Y is equal to

- A. $1.1 \times 10^{-14} \text{ V}$
- B. $7.4 \times 10^{-14} \text{ V}$
- C. $7.0 \times 10^4 \text{ V}$
- D. $1.2 \times 10^{16} \text{ V}$

Question 2

The electric field between the plates is equal to

- A. $1.2 \times 10^{-32} \text{ V m}^{-1}$
- B. $1.1 \times 10^{-14} \text{ V m}^{-1}$
- C. $7.4 \times 10^{-14} \text{ V m}^{-1}$
- D. $4.7 \times 10^5 \text{ V m}^{-1}$

Question 3

Electrons reaching plate *Y* in the electron gun would travel

- A. faster than those in the linac and slower than those in the storage ring.
- B. slower than those in the linac and slower than those in the storage ring.
- C. slower than those in the linac and faster than those in the storage ring.
- D. faster than those in the linac and faster than those in the storage ring.

Question 4

Radiation is emitted by an electron in the synchrotron when it

- A. is accelerated in a straight line.
- B. changes direction.
- C. stops suddenly.
- D. interacts with a photon.

Question 5

In the booster ring of a synchrotron an electron with momentum $2.3 \times 10^{-17} \text{ kg m s}^{-1}$ moves in a curve, due to the effect of a magnetic field of strength 4.8 T.

The radius of the curve along which the electron travels is equal to

- A. $2.7 \times 10^{-29} \text{ m}$
- B. $6.9 \times 10^{-19} \text{ m}$
- C. 0.03 m
- D. 30 m

Use the following information to answer Questions 6 and 7.

There are a number of devices which can be used in a synchrotron to control the type of synchrotron radiation produced or delivered to a beam line. These devices include the multipole wiggler, the undulator and the monochromator.

Question 6

Which of the following correctly summarises the role of a multipole wiggler, an undulator and a monochromator?

	Increases the intensity producing a broad beam of incoherent light	Increases intensity and results in narrow beam of coherent light	Selects photons of a specific wavelength
A.	multipole wiggler	undulator	monochromator
B.	undulator	multipole wiggler	monochromator
C.	multipole wiggler	monochromator	undulator
D.	monochromator	undulator	multipole wiggler

Question 7

Which of the following correctly summarises the location of a multipole wiggler, an undulator and a monochromator?

	multipole wiggler	undulator	monochromator
A.	linac	booster ring	storage ring
B.	beamline	beamline	storage ring
C.	storage ring	storage ring	beamline
D.	storage ring	booster ring	beamline

Question 8

An X-ray photon is incident on a stationary electron and undergoes Compton scattering. The wavelength of the scattered photon is 6.5×10^{-12} m.

The wavelength of the incident photon would be closest to

- A. 6.0×10^{-12} m
- B. 6.5×10^{-12} m
- C. 7.0×10^{-12} m
- D. 1.2×10^{-11} m

Question 9

Which of the following correctly describes Thomson scattering?

- A. Both momentum and kinetic energy are conserved in the collision.
- B. Kinetic energy is conserved in the collision but momentum is not conserved.
- C. Momentum is conserved in the collision but kinetic energy is not conserved.
- D. Neither momentum nor kinetic energy are conserved in the collision.

Use the following information to answer Questions 10 and 11.

X-ray photons are used to investigate the spacing between layers of atoms in a crystal, as shown in Figure 2.

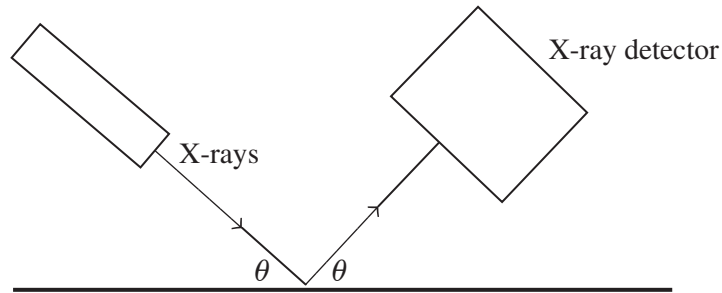

Figure 2

The second smallest angle through which X-ray photons are diffracted is found to be 7.4° for a crystal with a known atomic spacing of 1.0×10^{-10} m.

Question 10

The wavelength of the incident X-ray photons is equal to

- A. 3.2×10^{-12} m
- B. 6.4×10^{-12} m
- C. 1.3×10^{-11} m
- D. 2.6×10^{-11} m

Question 11

The next largest angle through which photons of this wavelength could be scattered by the crystal is

- A. 8.6°
- B. 11.2°
- C. 14.8°
- D. 22.2°

SECTION B**Instructions for Section B**

Choose **one** Detailed study and answer **all** questions within that Detailed study in pencil on the answer sheet provided for multiple-choice questions.

Show the Detailed study you are answering by shading the matching box on your multiple-choice answer sheet and writing the name of the Detailed study in the box provided.

Choose the response that is **correct** for the question.

A correct answer scores 2, an incorrect answer scores 0.

Marks will **not** be deducted for incorrect answers.

No marks will be given if more than one answer is completed for any question.

You should take the value of g to be 10 m s^{-2} .

Detailed study 5 – Photonics**Question 1**

The Sun produces incoherent light.

This means the Sun's light is

- A. out of phase.
- B. polychromatic.
- C. in phase.
- D. monochromatic.

Question 2

Red laser pointers are commonly used when giving lectures.

The light produced by a red laser is

- A. polychromatic and incoherent.
- B. polychromatic and coherent.
- C. monochromatic and incoherent.
- D. monochromatic and coherent.

Use the following information to answer Questions 3–5.

A light-emitting diode (LED) is shown in Figure 1. It has been manufactured to produce green light with a wavelength of 520 nm for use in traffic lights.

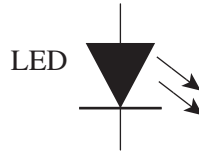

Figure 1

Question 3

The frequency of the light emitted by this green LED is

- A. 3.0×10^8 Hz
- B. 5.2×10^{14} Hz
- C. 5.8×10^{14} Hz
- D. 5.8×10^{15} Hz

Question 4

The energy gap required to produce this 520 nm green light is

- A. 1.2 eV
- B. 2.4 eV
- C. 5.2 eV
- D. 5.8 eV

Question 5

The light emitted by this LED is a result of the

- A. transition of electrons from a higher energy state to a lower energy state.
- B. transition of electrons from a lower energy state to a higher energy state.
- C. movement of electrons from the conduction band to the valence band of a semiconductor.
- D. thermal motion of electrons.

Use the following information to answer Questions 6 and 7.

The Australian National Broadband Network (NBN) involves many millions of kilometres of optical fibres being laid in trenches across Australia. Modal dispersion can be a serious problem with using optical fibres.

Question 6

Modal dispersion in optical fibres occurs because different modes

- A. have different frequencies in the optical fibre.
- B. take different paths while travelling through the optical fibre.
- C. have different wavelengths in the optical fibre.
- D. interfere with each in the optical fibre.

Question 7

Modal dispersion can be minimised by using a

- A. larger angle of acceptance.
- B. step-index fibre.
- C. smaller angle of acceptance.
- D. graded-index fibre.

Question 8

Optical fibre sensor systems are used in aeroplanes to measure the stress forces acting on various parts of the fuselage caused by variations in loads (e.g. wind factors, passengers and luggage weight, amount of fuel used, etc.). One aeroplane sensor system uses infrared laser light.

The optical fibre sensor system works because stress forces in the plane

- A. bend the infrared light.
- B. modulate the intensity of the infrared light.
- C. convert the infrared light into visible light.
- D. modulate the frequency of the infrared light.

Use the following information to answer Questions 9–11.

An optical fibre used in Photonics experiments for VCE Physics is shown in Figure 2.

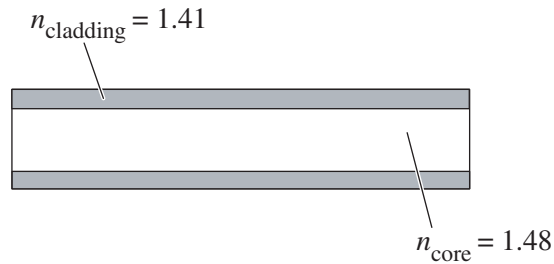

Figure 2

Question 9

The critical angle for this optical fibre is

- A. 11.4°
- B. 17.7°
- C. 72.3°
- D. 78.6°

Question 10

The VCE students use the optical fibre in air ($n = 1.00$). The acceptance angle for this optical fibre is

- A. 17.7°
- B. 26.7°
- C. 63.3°
- D. 72.3°

Question 11

The VCE students now place the optical fibre in water ($n = 1.33$) to capture light.

As a result of this the critical angle

- A. becomes larger and the acceptance angle becomes larger.
- B. stays the same and the acceptance angle becomes larger.
- C. stays the same and the acceptance angle becomes smaller.
- D. becomes smaller and the acceptance angle stays the same.

SECTION B**Instructions for Section B**

Choose **one** Detailed study and answer **all** questions within that Detailed study in pencil on the answer sheet provided for multiple-choice questions.

Show the Detailed study you are answering by shading the matching box on your multiple-choice answer sheet and writing the name of the Detailed study in the box provided.

Choose the response that is **correct** for the question.

A correct answer scores 2, an incorrect answer scores 0.

Marks will **not** be deducted for incorrect answers.

No marks will be given if more than one answer is completed for any question.

You should take the value of g to be 10 m s^{-2} .

Detailed study 6 – Sound

For all questions in this detailed study, the speed of sound in air is equal to 340 m s^{-1} .

A local secondary school is conducting a fire drill. The fire alarm siren produces a sound with a wavelength of 6.8 cm.

Question 1

The frequency of the fire alarm siren is equal to

- A. $2.0 \times 10^{-2} \text{ Hz}$
- B. 50 Hz
- C. 500 Hz
- D. 5000 Hz

During the fire drill Mr Potter, one of the Music teachers, is required to test the operation of the loudspeakers which transmit the fire alarm siren. He walks a distance of 10 m from the loudspeaker and measures the sound intensity level to be 93 dB.

Question 2

The intensity of the fire alarm siren 10 m from the loudspeaker is equal to

- A. $9.3 \times 10^{-11} \text{ W m}^{-2}$
- B. $2.0 \times 10^{-3} \text{ W m}^{-2}$
- C. $4.8 \times 10^{-3} \text{ W m}^{-2}$
- D. 501 W m^{-2}

Mr Potter now moves to a distance of 40 m from the siren.

Question 3

The sound intensity level at this location will be equal to

- A. 5.8 dB
- B. 23 dB
- C. 81 dB
- D. 85 dB

After the fire drill Mr Potter returns to the school auditorium, where a music rehearsal is taking place. Isobel, one of the vocalists, is using a dynamic microphone.

Question 4

Which one of the following alternative microphone types operates using the same physics principles as the dynamic microphone?

- A. electret-condenser microphone
- B. crystal microphone
- C. velocity microphone
- D. carbon microphone.

The school auditorium has an extensive sound system with numerous loudspeakers located around the auditorium. Each of these loudspeakers is enclosed in a box, sometimes referred to as a 'baffle'.

Question 5

The purpose of the baffle is to

- A. reduce destructive interference between sound waves from the front and the back of the speaker.
- B. increase constructive interference between sound waves from the front and the back of the speaker.
- C. increase destructive interference between sound waves from the front and the back of the speaker.
- D. reduce constructive interference between sound waves from the front and the back of the speaker.

The diagram in Figure 1 shows the simplified structure of a typical loudspeaker.

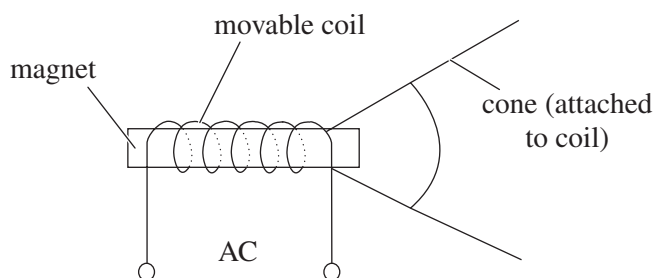

Figure 1

Question 6

When the speaker is operating, the speaker cone moves backwards and forwards because the

- A. induced current in the magnet interacts with the current in the moveable coil.
- B. changing magnetic field around the moveable coil interacts with the magnetic field of the magnet.
- C. induced magnetic field in the magnet interacts with the current in the moveable coil.
- D. induced current in the moveable coil interacts with the current supplied to the coil.

One of the speakers in the auditorium is located behind a large screen of width 2.5 m. It is observed, however, that the sound produced by the speaker is clearly and loudly heard at position X in Figure 2.

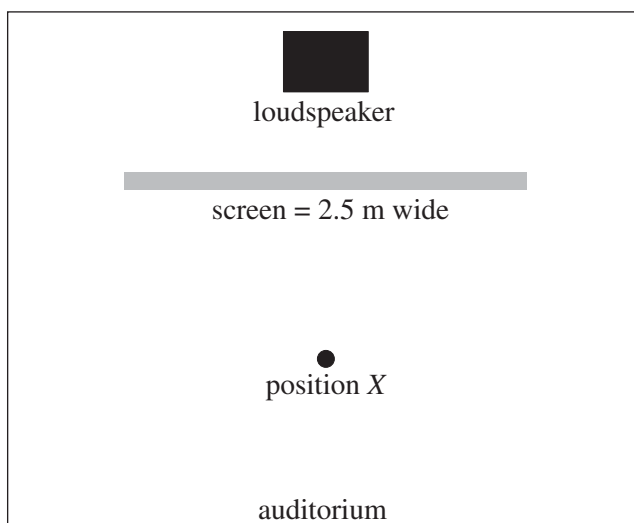

Figure 2

Question 7

The speaker behind the screen is most likely to produce sounds with a frequency range of

- A. 0–15 Hz
- B. 30–130 Hz
- C. 150–300 Hz
- D. 1000–3000 Hz

Jack is another student in the auditorium and is playing the guitar at the rehearsal. Jack plucks one of his guitar strings to produce a travelling wave with a wavelength λ . A standing wave is produced as a result of this travelling wave.

Question 8

In terms of the wavelength of the travelling wave λ , the standing wave produced will have a wavelength equal to

- A. $\frac{\lambda}{2}$
- B. λ
- C. $\frac{3\lambda}{2}$
- D. 2λ

Jack plays a note of frequency 526 Hz on his guitar. This is the fundamental frequency for this length of string.

Question 9

If the string length is equal to 65 cm, the speed of the wave in the string is

- A. 171 m s^{-1}
- B. 342 m s^{-1}
- C. 684 m s^{-1}
- D. 1368 m s^{-1}

Molly, a trumpet player, wishes to produce the same frequency note as Jack (526 Hz) on the trumpet. She does so by producing the third harmonic. The trumpet can be modelled as a pipe closed at one end and the speed of sound of air in the trumpet is equal to 340 m s^{-1} .

Question 10

The air column length in the trumpet which resonates to produce 526 Hz as the third harmonic is

- A. 0.48 m
- B. 0.97 m
- C. 1.1 m
- D. 1.5 m

The graph shown in Figure 3 represents the hearing frequency response of Eliza, who is operating the mixing equipment in the auditorium.

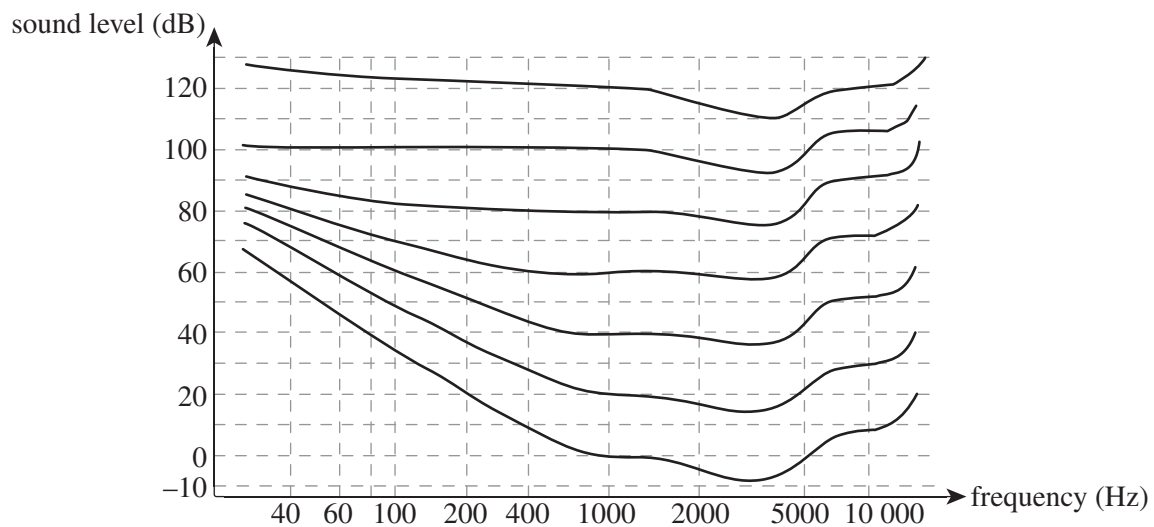

Figure 3

Question 11

The information in the graph shown in Figure 3 indicates that

- A. Eliza is most sensitive to sounds with frequency greater than 8000 Hz.
- B. at 100 dB Eliza perceives sounds in the range 40–1000 Hz to have similar loudness.
- C. a 200 Hz sound at 20 dB will be perceived by Eliza to have a loudness of 40 dB.
- D. Eliza will always perceive sounds with frequencies lower than 80 Hz to sound louder than they actually are.

END OF QUESTION AND ANSWER BOOKLET