



**INSIGHT**  
*Trial Exam Paper*  
**2009**

**PHYSICS**  
**Written examination 2**

**STUDENT NAME:**

**QUESTION AND ANSWER BOOK**

Reading time: 15 minutes  
Writing time: 1 hour 30 minutes

**Structure of book**

<i>Section</i>	<i>Number of questions</i>	<i>Number of questions to be answered</i>	<i>Number of marks</i>
<b>A – Core – Areas of Study</b>			
1. Electric power	18	18	40
2. Interactions of light and matter	11	11	24
<b>B – Detailed Studies</b>			
1. Synchrotron and its applications	13	13	26
OR			
2. Photonics	13	13	26
OR			
3. Sound	13	13	26
Total			90

- Students are permitted to bring the following items into the examination: pens, pencils, highlighters, erasers, sharpeners, rulers and one scientific calculator.
- Students are NOT permitted to bring sheets of paper or white out liquid/tape into the examination.

**Materials provided**

- The question and answer book of 43 pages, with a separate data sheet.

**Instructions**

- Write your **name** in the box provided.
- Remove the data sheet during reading time.
- Answer all the questions in the space provided.
- Always show your working where space is provided.
- Where the answer box has a unit printed in it, give your answer in that unit.
- You must answer all questions in English.

**Students are NOT permitted to bring mobile phones or any other electronic device into the examination.**

This trial examination produced by Insight Publications is NOT an official VCAA paper for the 2009 Physics written examination 2.

This examination paper is licensed to be printed, photocopied or placed on the school intranet and used only within the confines of the purchasing school for examining their students. No trial examination or part thereof may be issued or passed on to any other party including other schools, practising or non-practising teachers, tutors, parents, websites or publishing agencies without the written consent of Insight Publications.

Copyright © Insight Publications 2009

**SECTION A – Core****Area of study 1 – Electric power**

*The following information applies to Questions 1–4.*

Figure 1 shows a wire of length 30 cm carrying 2 A of current placed in a uniform magnetic field of magnitude 5 mT in two different orientations, A and B.

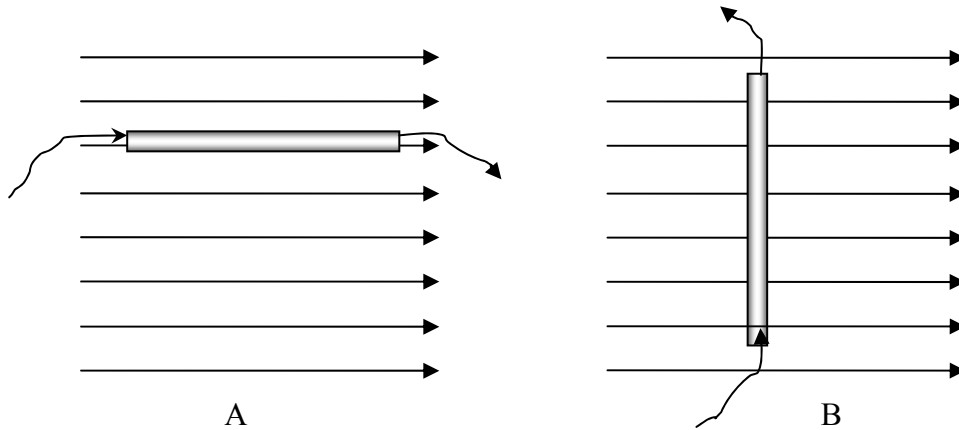

**Figure 1**

**Question 1**

What is the magnitude of the magnetic force on the wire in orientation A? Explain your answer.

---



---



---

N

2 marks

**Question 2**

What is the magnitude and direction of the magnetic force on the wire in orientation B?

---



---



---

N
---

Direction:
------------

3 marks

**Question 3**

Explain, referring to magnetic fields, the principle reason **why** the current-carrying conductor experiences the magnetic force when placed in the magnetic field.

---



---



---



---



---

2 marks

**Question 4**

The current in the wire is switched off and the battery replaced with an ammeter. The wire is withdrawn perpendicular to the field at a speed of  $10 \text{ ms}^{-1}$ . What is the magnitude of the maximum induced current in the wire? Resistance of the wire and the circuit is  $5 \Omega$ .

---



---



---



---



---

mA
----

2 marks

The following information applies to Questions 5–8.

Farmer Jo obtains electricity for his farmhouse by a hydro-electric generator, making use of a natural waterfall in the valley below (Figure 2). The generator produces 6000 W at  $V_{\text{RMS}}$  of 1200 V. There is one transformer near his farmhouse that steps down the voltage to suit his needs.

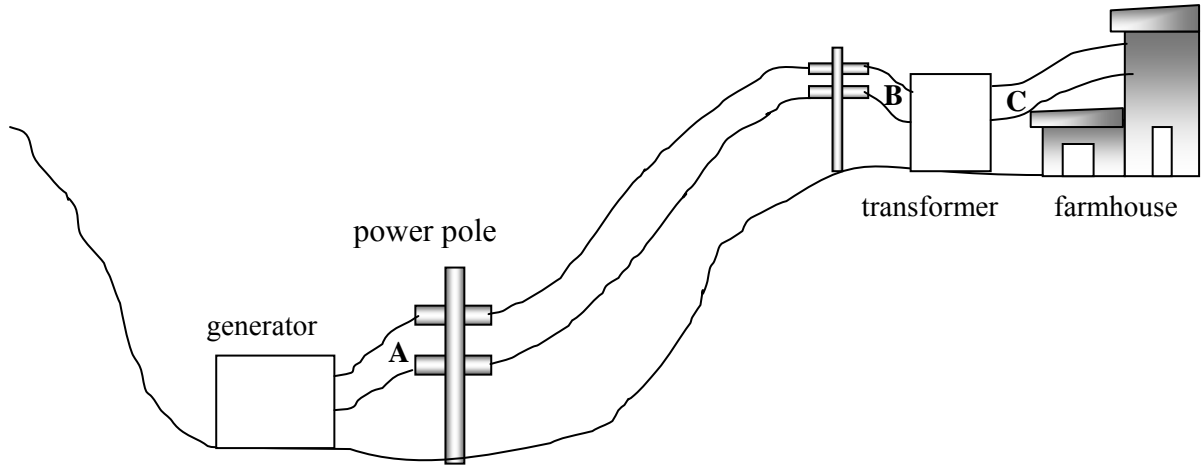

Figure 2

### Question 5

What is the RMS current in the transmission lines at location A?

---



---



---

A
---

2 marks

### Question 6

The total resistance of the transmission lines between locations A and B is  $5 \Omega$ . What is the RMS voltage supplied to the transformer at location B?

---



---



---

V
---

3 marks

**Question 7**

Farmer Jo receives  $235 V_{\text{RMS}}$  at location C as a result of the transformer action between locations B and C. What is the ratio of the turns in the primary coil to the secondary coil of the transformer?

---



---



---

: 1
-----

2 marks

**Question 8**

Farmer Jo's friend Jim recommends installing the transformer near the generator at location A in order to save power, but Farmer Jo wishes to keep it at its current location. The transformer could be, if needed, switched around so its primary and secondary ends are reversed. Using appropriate calculation, compare and contrast the effects of locating the transformer at location A compared with its current location at C, and determine who is correct. Assume the transformer to be 100% efficient.

---



---



---



---



---



---



---



---



---



---

3 marks

The following information applies to Questions 9 and 10.

A flat coil of 10 turns and dimensions  $2\text{ cm} \times 2\text{ cm}$  is placed between the poles of a magnet and its behaviour studied as it rotates around the axis. The experimental apparatus is shown in Figure 3.

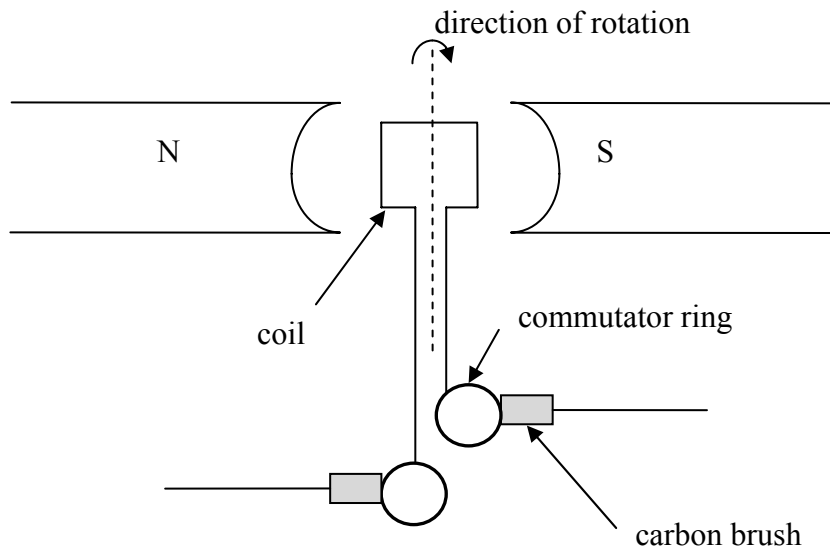

**Figure 3**

Starting from a certain position at time  $t = 0\text{ s}$ , the variation of flux with time is shown in Figure 4 for the first  $0.04\text{ s}$ .

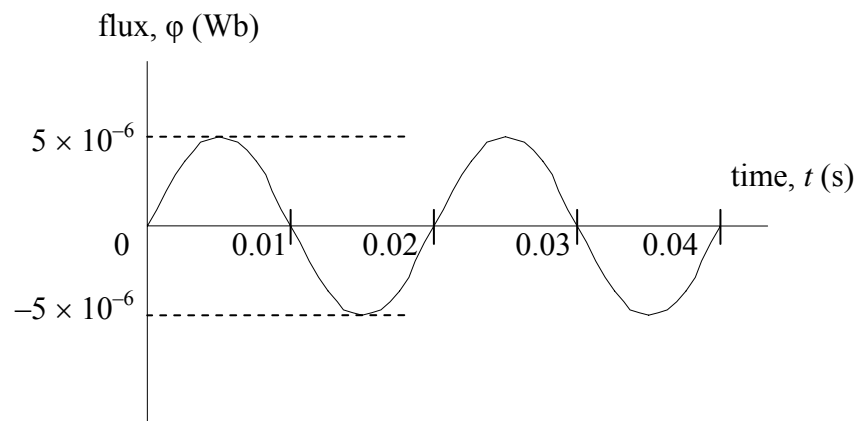

**Figure 4**

**Question 9**

What is the magnitude of the maximum magnetic field strength experienced by the coil?

---



---



---

T

2 marks

**Question 10**

A CRO measures the voltage output across the commutator as a function of time. On the axes sketched in Figure 5, which shows the original variation of flux with time, sketch the CRO voltage signal for time  $t = 0$  to  $t = 0.04$  s. Show your working and add a suitable scale on the y-axis.

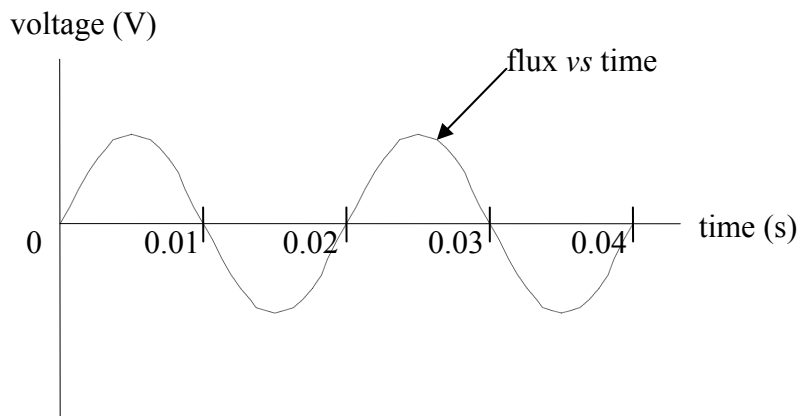
**Figure 5**

3 marks

The following information applies to Questions 11 and 12.

A 20-turn flat coil DC motor of sides  $3\text{ cm}^2$  is spinning at a frequency of 50 Hz in a uniform magnetic field of strength 5 mT. The current in the coil is measured to be 3 A.

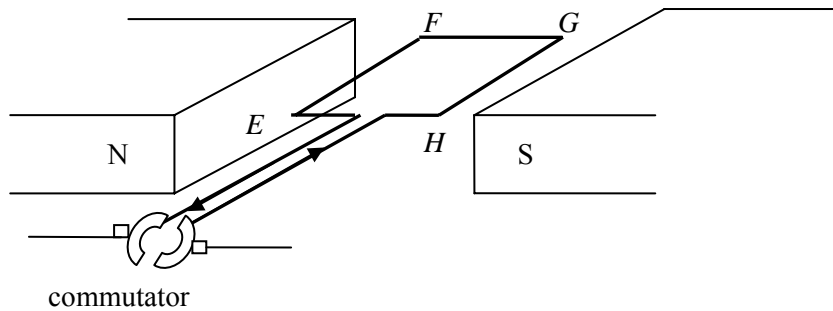

Figure 6

### Question 11

Starting from the position shown in Figure 6, what is the magnitude of the magnetic force on side  $EF$  at time  $t = 0\text{ s}$ ?

---



---



---

N

2 marks

### Question 12

Looking at the coil from the location of the commutator, will the motor spin clockwise or anticlockwise? Explain your answer.

---



---



---

2 marks



The following information applies to Questions 13 and 14.

A permanent magnet is set into oscillations by the use of a spring such that the north pole of the magnet enters a solenoid briefly and then oscillates about its mean position. It is assumed that the motion of the magnet is not influenced measurably by air friction.

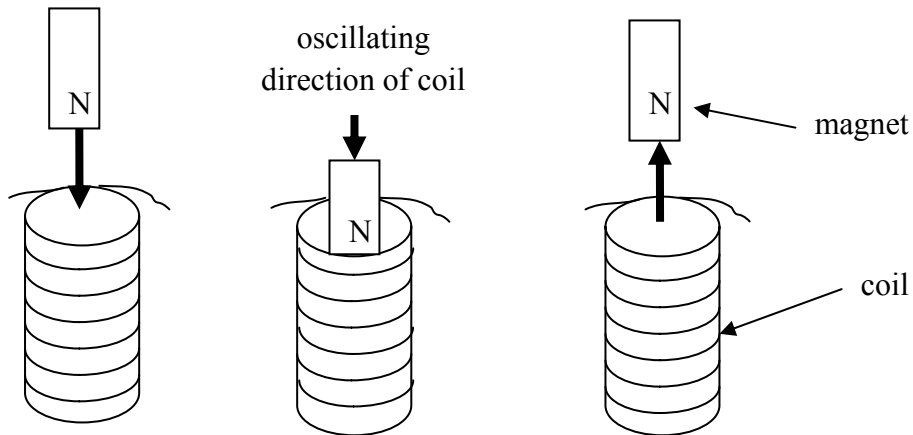

Figure 7

**Question 13**

What is the direction of induced current as the magnet inserts into the solenoid? Explain your answer.

---



---



---

2 marks

**Question 14**

Explain what would be the effect of doubling the frequency of the magnet's oscillation on the induced EMF.

---



---



---

2 marks

**Question 15**

An electromagnet is shown in Figure 8. Sketch **three** significant lines of magnetic field created in and around the electromagnet due to the current.

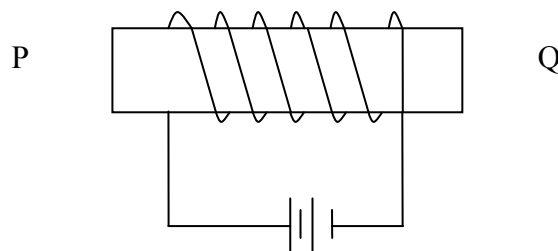
**Figure 8**

2 marks

*The following information applies to Questions 16–18.*

A light bulb is lit up using a 9 V DC battery and a **small** amount of current, as shown in Figure 9.

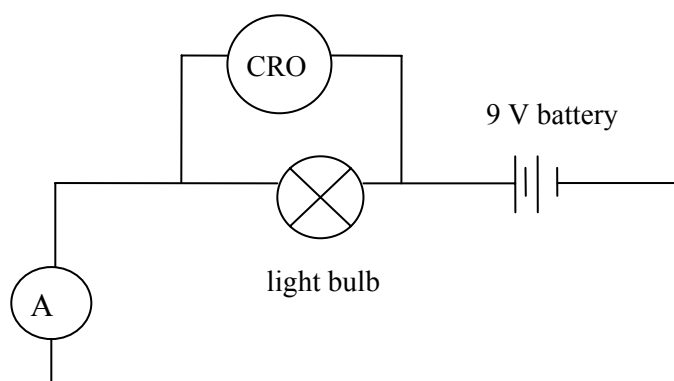
**Figure 9**

**Question 16**

Which of the following graphs, A to D, best represents the lamp's voltage versus current graph?

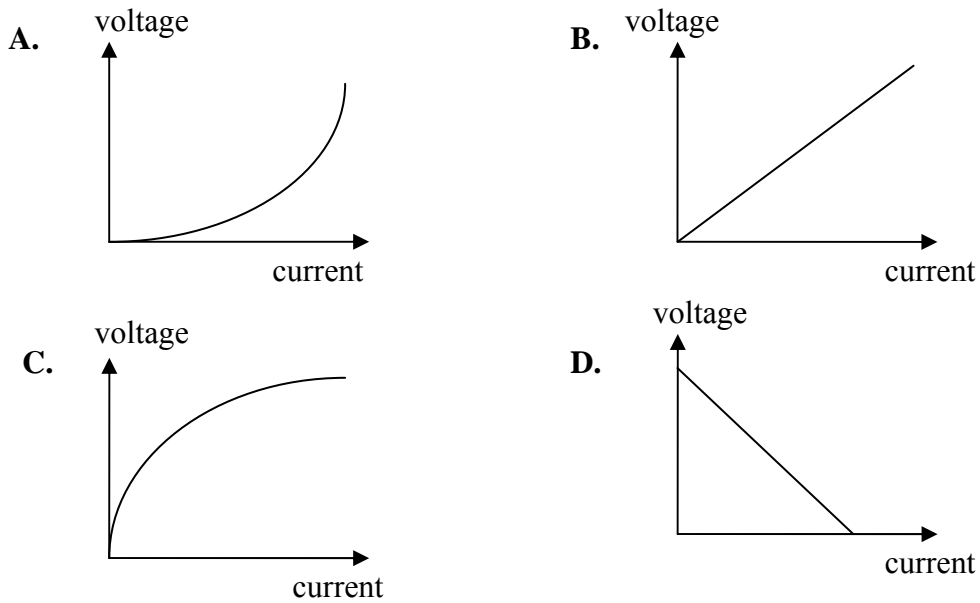
**Figure 10**

2 marks

**Question 17**

Which of the following graphs, A to D, best represents the lamp's power loss versus current?

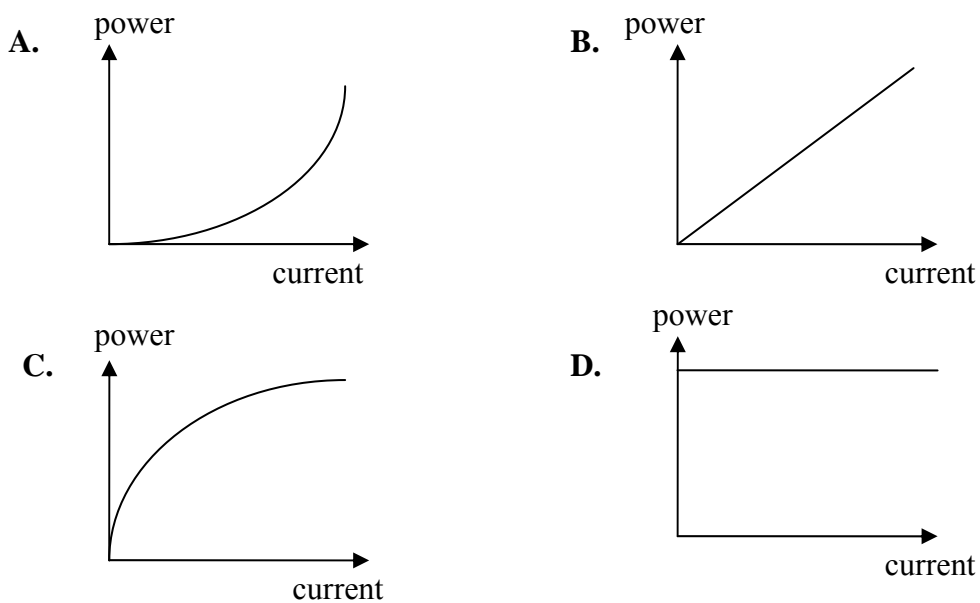
**Figure 11**

2 marks

**SECTION A – Area of study 1 – continued**  
**TURN OVER**

**Question 18**

The 9 V DC battery is now replaced by a variable AC power supply. What AC peak voltage will give the same lighting effect of the light bulb as the 9 V DC battery?

---

---

V
---

2 marks

## Area of study 2 – Interactions of light and matter

Use the following information to answer Questions 1–4.

A certain gas is being researched when in its ground state. Its energy level diagram is shown in Figure 1.

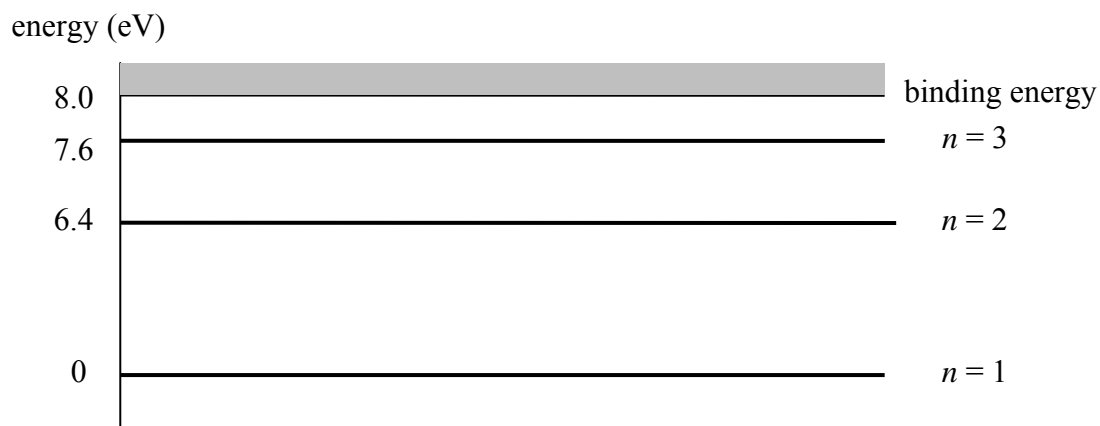

**Figure 1**

### Question 1

What would be the longest wavelength expected in the absorption spectra of the gas in its ground state?

---



---



---



---

nm

2 marks

### Question 2

Estimate one wavelength that exists in the emission spectra but not in the absorption spectra for the gas when in its ground state.

---



---



---



---

nm

2 marks

**SECTION A – Area of study 2 – continued**  
**TURN OVER**

A sample of this gas, which is enclosed in a glass vessel at room temperature, is subjected to a monochromatic beam as part of a research project. When Steven shines a monochromatic beam of 8.3 eV onto this gas, electrons are released and an absorption line is also seen in the absorption spectra. However, when Casey shines a monochromatic beam of 7.4 eV, no electrons are released and no lines are seen in the absorption spectra.

**Question 3**

Explain, with reference to energy levels of the gas, why Steven saw an absorption line whereas Casey did not.

---

---

---

---

---

---

---

2 marks

**Question 4**

What will be the maximum kinetic energy of the electrons released in Steven's experiments?

---

---

---

---

J
---

2 marks

Use the following information to answer Question 5.

A beam of electrons is generated in an electron gun and travels through a vacuum chamber under an accelerating voltage of 12 000 V. The beam is intercepted by a mono-atomic crystal, which is acting as a diffraction grating.

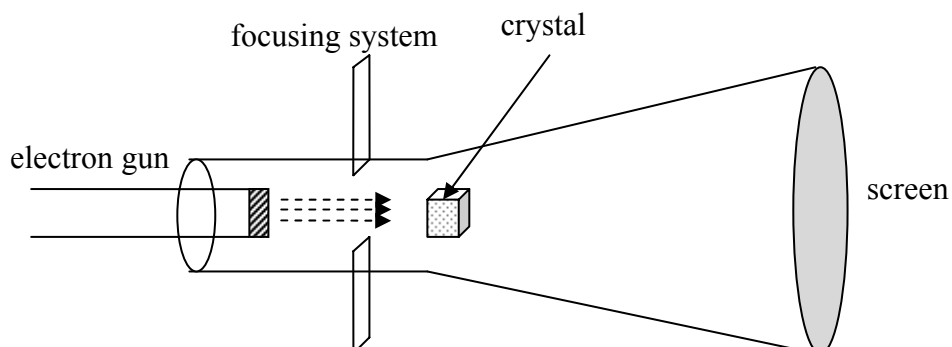

**Figure 2**

**Question 5**

Calculate the de Broglie wavelength of the electrons at the instant they strike the crystal.

---

---

---

---

---

---

---

---

---

---

3 marks

Use the following information to answer Questions 6 and 7.

A laser light beam, which is monochromatic and coherent, and of wavelength 450 nm, is shone through a pair of narrow slits, 0.15 mm apart, as part of an investigation of Young's experiment, as shown in Figure 3. A pattern of high-intensity lines separated by regions of darkness are observed on the screen, which is placed 2.5 m away from the slits.

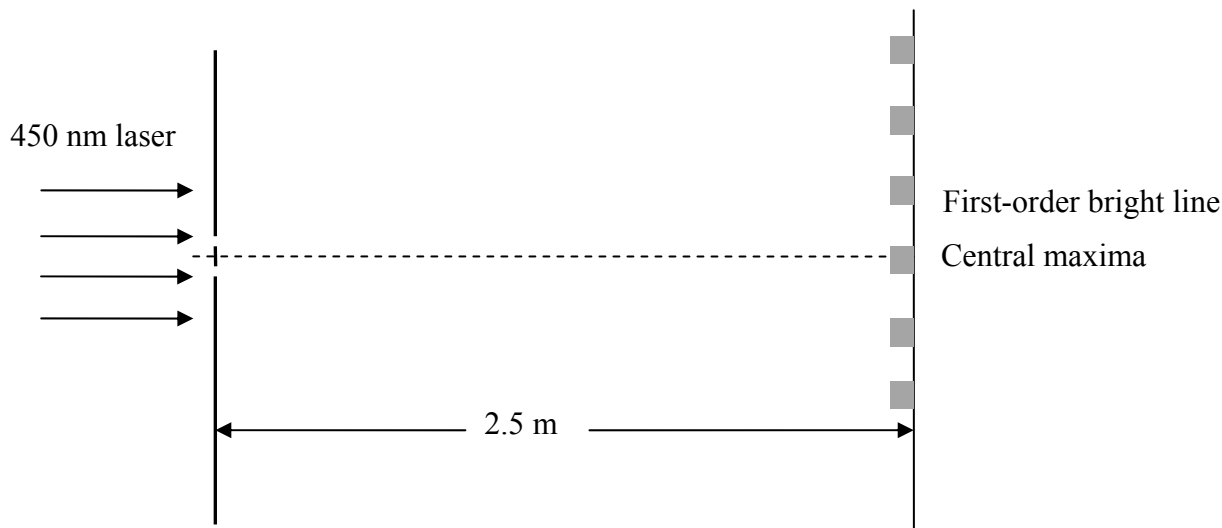

Figure 3

### Question 6

What will be the distance of the first-order bright intensity line from the centre of the central maxima?

---



---



---



---



---



---

mm

2 marks

### Question 7

If one of the slits is covered up, estimate the **maximum** width of the single slit that is needed in order to see significant diffraction. Explain the reasoning for your answer.

---



---



---



---

nm

2 marks



Use the following information to answer Questions 8–11.

The photoelectric properties of a metal were studied by using a photoelectric cell where the metal is used as a photocell and the light source has monochromatic but variable frequency. Such a light source could be a tuneable laser. The data were plotted in two different ways and are shown in Figures 4a and 4b. In Figure 4a, the magnitude of photocurrent is plotted against stopping voltage,  $V_s$ , for a certain frequency ' $f_1$ '. In Figure 4b, the maximum kinetic energy of the emitted photoelectron is graphed against a range of frequencies.

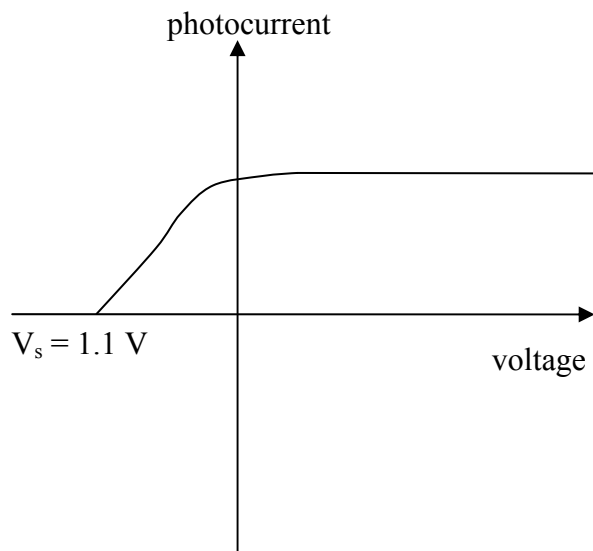

Figure 4a

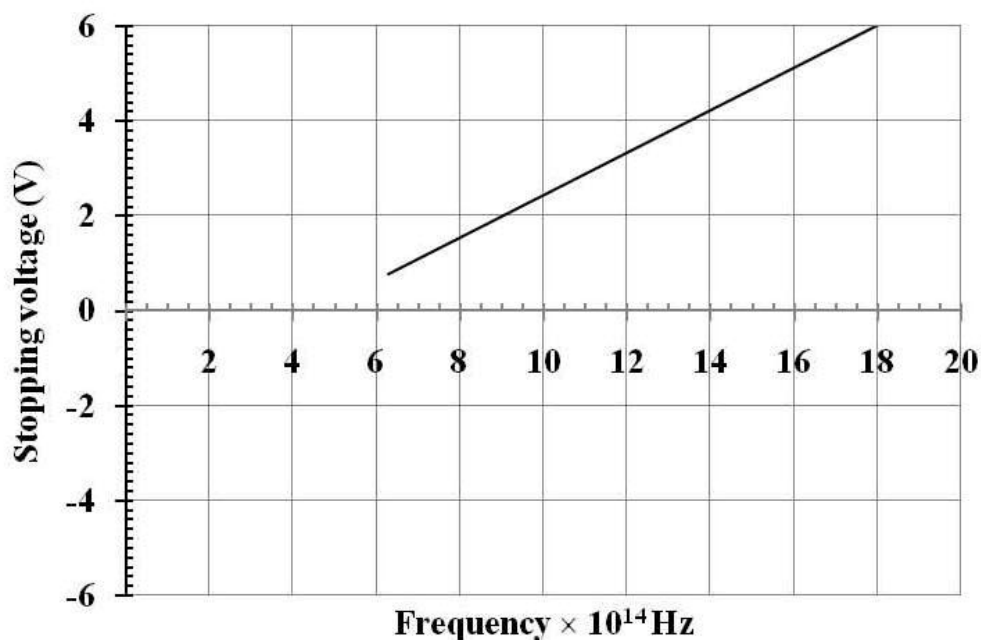

Figure 4b

**Question 8**

Use the graphical data from Figures 4a and 4b to determine the frequency of light, ' $f_1$ ', used in this experiment.

---



---



---

Hz
----

2 marks

**Question 9**

Which of the graphs, A to D, best represents the outcome when the frequency of the incident light beam is increased **and** the intensity of the incident light beam is decreased? The original light beam (dashed line) is shown for reference. Explain your choice of answer.

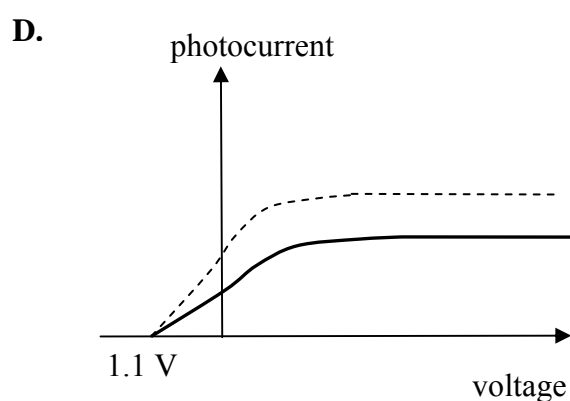
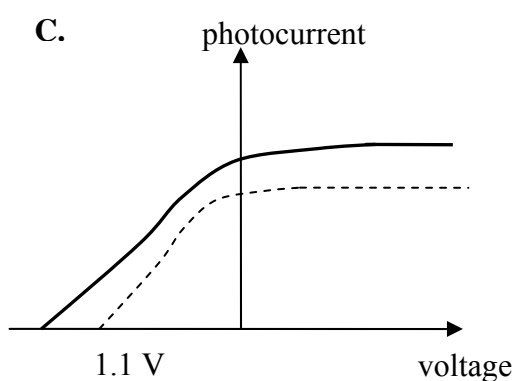
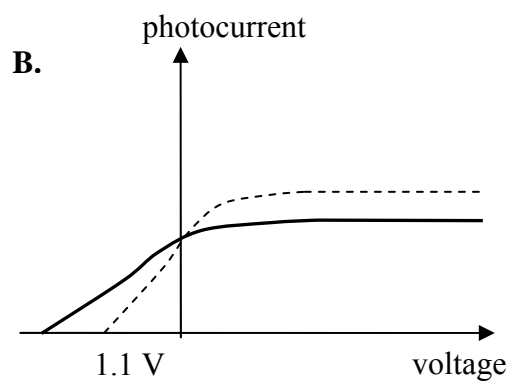
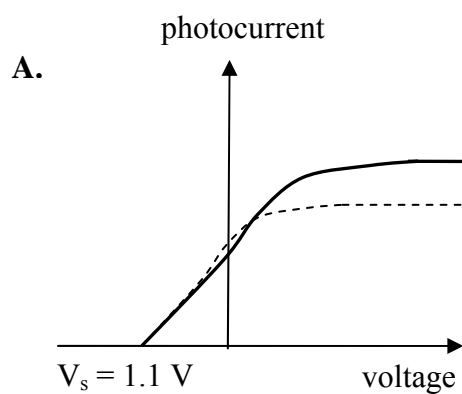

---



---



---

--

2 marks

**Question 10**

From the graphical data of Figures 4a and 4b, determine the work function of the metal. Show your working.

---

---

---

eV
----

2 marks

**Question 11**

Using the graphical data from Figures 4a and 4b, what is the value of Planck's constant? You must show your working.

---

---

---

---

Js
----

3 marks

**END OF SECTION A  
TURN OVER**

**SECTION B – Detailed studies****Detailed study 1 – Synchrotron and its applications**

An electron gun is used to produce electrons of different velocities by appropriately tuning the accelerating electron. A construction of a typical electron gun is shown in Figure 1.

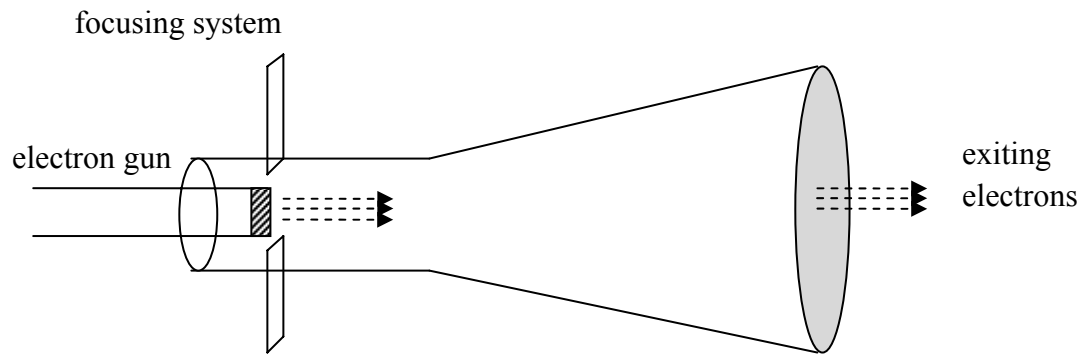

**Figure 1**

**Question 1**

What is the voltage necessary to generate electrons of kinetic energy 1 GeV?

- A. 1 gigavolt
- B. 1.6 gigavolt
- C.  $1.6 \times 10^{-19}$  V
- D.  $1.6 \times 10^{-13}$  V

2 marks

**Question 2**

What is the speed of electrons upon exiting from the gun when the accelerating voltage is 2500 V?

- A. About  $2 \times 10^7 \text{ ms}^{-1}$ .
- B. About  $2.5 \times 10^6 \text{ ms}^{-1}$ .
- C. About  $3 \times 10^8 \text{ ms}^{-1}$ .
- D. About  $3 \times 10^7 \text{ ms}^{-1}$ .

---

---

---

---

---

---

---

2 marks

**Question 3**

An electron with velocity  $3 \times 10^6 \text{ ms}^{-1}$  enters a uniform magnetic field of  $5 \times 10^{-3} \text{ T}$ , as shown in Figure 2. The force on the electron is best described as

- A.  $1.5 \times 10^4 \text{ N}$  to the right.
- B.  $2.4 \times 10^{-15} \text{ N}$  to the left.
- C.  $2.4 \times 10^{-15} \text{ N}$  to the right.
- D.  $1.5 \times 10^4 \text{ N}$  to the left.

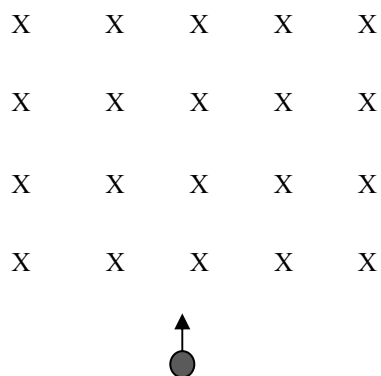

**Figure 2**

---



---



---

2 marks

*Use the following information to answer Questions 4–7.*

The following statements, A to D, refer to the functioning and design of one component of the Australian synchrotron.

- A. Electrons are kept in a circular path for hours at a time and close to the speed of light. Synchrotron light is emitted when electrons change direction. Loss of energy due to synchrotron radiation is replenished by RF chambers.
- B. Electrons are bent into a circular path by magnets positioned at right angles to the electron beam. Energy of the electrons is increased as they travel through built-in RF chambers.
- C. It produces electrons and accelerates them across a potential difference in a high vacuum chamber, using focusing systems to narrow the beam.
- D. Situated within the storage ring and consisting of alternating magnetic poles, this component increases the brightness of the synchrotron light.

For Questions 4–7, identify the component of the Australian synchrotron with its function described in statements A, B, C or D.

**Question 4**

The ‘linac’:

2 marks

**Question 5**

The circular booster:

2 marks

**Question 6**

The storage ring:

2 marks

**Question 7**

Wigglers:

2 marks

*Use the following information to answer Questions 8 and 9.*

Crystal diffraction analysis is carried out on a sample of a newly developed crystalline material using a 1.5 keV X-ray beam. In the first experiment, the X-ray beam, with energy 1.5 keV, is produced by a normal laboratory X-ray tube. In the second experiment on the same crystalline material, the X-ray beam is produced by a synchrotron.

**Question 8**

In the context of X-ray diffraction, which of the following statements best describes the advantage of X-rays produced by the synchrotron over those produced by a normal laboratory X-ray tube?

- A.** The beam produced by the synchrotron is coherent, which results in a better resolution.
- B.** The beam produced by the synchrotron has a much narrower range of wavelengths, which results in a better resolution.
- C.** The beam produced by the synchrotron has a higher intensity and a low divergence, which contributes to a better resolution.
- D.** The beam produced by the synchrotron has very high energy.

2 marks

**SECTION B – Detailed study 1 – continued**  
**TURN OVER**

**Question 9**

A crystal of the new material shows a diffraction image with the 1.5 keV X-ray beam. A graph of X-ray diffracted intensity versus angle shows a sharp line at  $28^\circ$ , as shown in Figure 3.

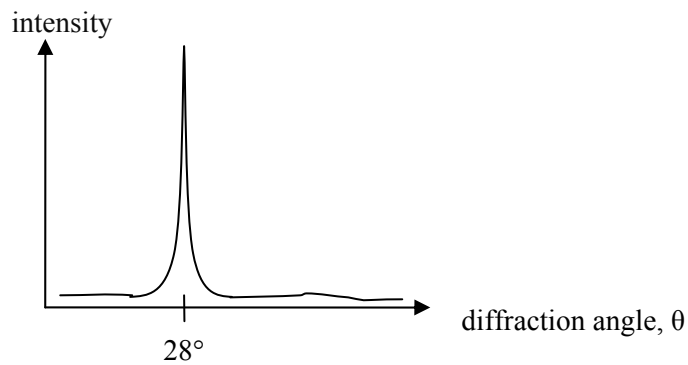
**Figure 3**

The inter-atomic distance is most likely to be

- A.  $3.1 \times 10^{-10}$  m
- B.  $2.4 \times 10^{-9}$  m
- C.  $8.8 \times 10^{-10}$  m
- D.  $8.3 \times 10^{-10}$  m

---

---

---

---

---

---

---

2 marks



**Question 10**

As electrons bend in a circular path in a synchrotron, the photon beam is produced

- A. tangent to the path of the electron beam.
- B. perpendicular to the path of the electron beam and directed towards the centre of the circular path.
- C. along the path of the electron beam.
- D. perpendicular to the path of the electron beam and directed away from the centre of the circular path.

2 marks

**Question 11**

The radiation produced in the Australian synchrotron is called 'synchronous'. Which one of the following is the best explanation of this definition?

- A. All radiation produced has the same energy and, hence, is of a single wavelength. This allows for exceptionally detailed analysis of materials.
- B. Electrons that release radiation are of nearly equal energy as they travel in circular paths in the storage ring. The radiation they release upon bending consists of a range of wavelengths.
- C. The radiation produced is very intense and monochromatic.
- D. All radiation produced is in phase.

2 marks

Use the following information to answer Questions 12 and 13.

A photon of wavelength 0.08 nm scatters from a graphite sample within an X-ray tube, as shown in Figure 4. A scattered photon of wavelength 0.09 nm and an electron are detected, consistent with the Compton effect.

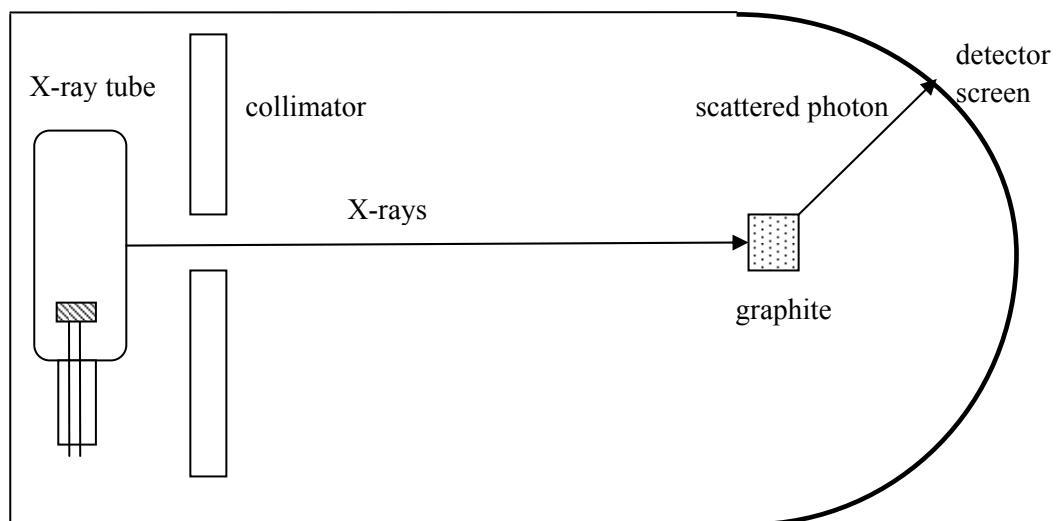

**Figure 4**

**Question 12**

What is the kinetic energy of the electron? Show your working.

- A. 1530 eV
- B. 100 eV
- C. 1600 eV
- D. 1725 eV



---



---



---



---

2 marks

**Question 13**

Which one of the following statements best contrasts Compton and Thomson scattering?

- A.** Compton scattering is an *elastic* collision between an incident photon and an electron and there is no wavelength shift in the photon. Thomson scattering is an *inelastic* collision and there is a wavelength shift in the scattered photon.
- B.** Thomson scattering is an *elastic* collision between an incident photon and an electron and there is no wavelength shift in the photon. Compton scattering is an *inelastic* collision and there is a wavelength shift in the scattered photon.
- C.** Thomson scattering is an *inelastic* collision between an incident photon and an electron and there is a wavelength shift in the photon. Compton scattering is an *elastic* collision and there is no wavelength shift in the scattered photon.
- D.** Thomson scattering is an *inelastic* collision between an incident photon and an electron and there is no wavelength shift in the photon. Compton scattering is an *elastic* collision and there is a wavelength shift in the scattered photon.

2 marks

**END OF DETAILED STUDY 1**  
**SECTION B – continued**  
**TURN OVER**

## Detailed study 2 – Photonics

Use the following information to answer Questions 1 and 2.

A piece of iron at room temperature is heated until it glows white hot. The emitted colour taken at various temperatures, P, Q, R and S, is shown in Figure 1.

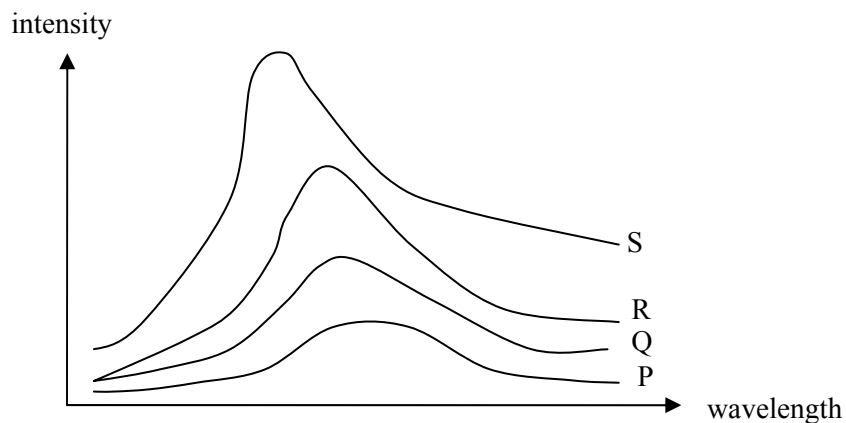

**Figure 1**

### Question 1

The magnitude of temperature decreases in the sequence

- A.  $S > Q > R > P$
- B.  $S > R > Q > P$
- C.  $P > Q > R > S$
- D.  $P > R > Q > S$

2 marks

### Question 2

Which of the following statements best describes the principal cause of the spectrum?

- A. Thermal motion of electrons.
- B. A wide variety of sources, including accelerating electrons and protons.
- C. Energy transformations in the nucleus.
- D. Chemical changes in the material.

2 marks

Use the following information to answer Questions 3 and 4.

A newly developed semiconductor LED has a band gap of 1.7 eV. To research its light-emitting properties the LED is connected in a circuit, as shown in Figure 2.

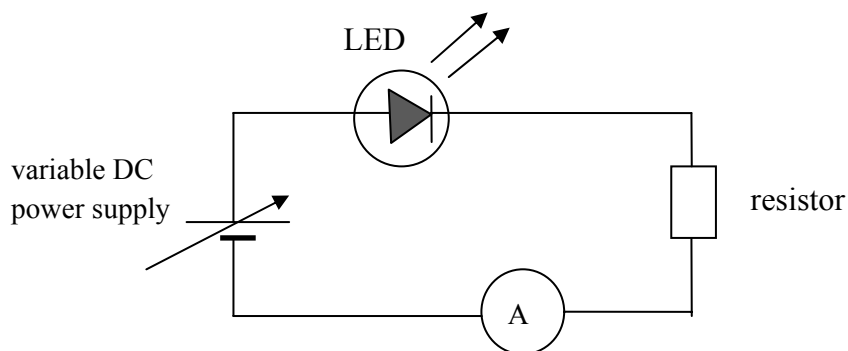
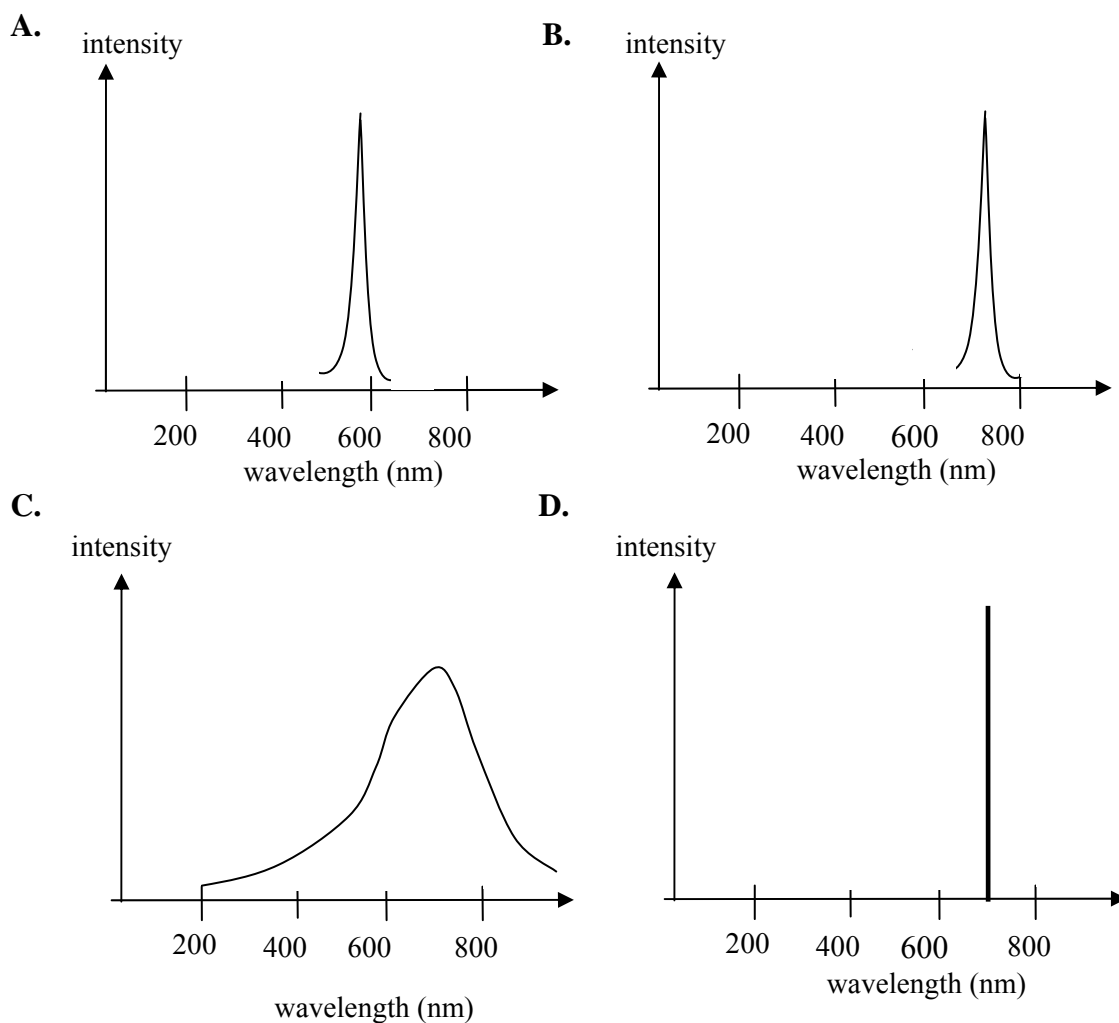

Figure 2

### Question 3

Which of the following is the most likely shape of the spectrum emitted by the LED?



2 marks

SECTION B – Detailed study 2 – continued  
TURN OVER

**Question 4**

The experiment is repeated with another sample of the LED material but is now found to be emitting a **lower** intensity, although the average wavelength does not change. Which of the following is the most likely cause?

- A. The battery is providing a higher voltage than previously.
- B. The battery is providing a lower voltage than previously.
- C. Some impurities are present in the LED.
- D. The LED is connected in reverse bias.

2 marks

*Use the following information to answer Questions 5–7.*

A ray of light enters a step-index optical fibre from air and undergoes total internal reflection at the core-cladding interface, as shown in Figure 3. The refractive index of air, core and cladding are, respectively, 1.00, 1.52 and 1.49.

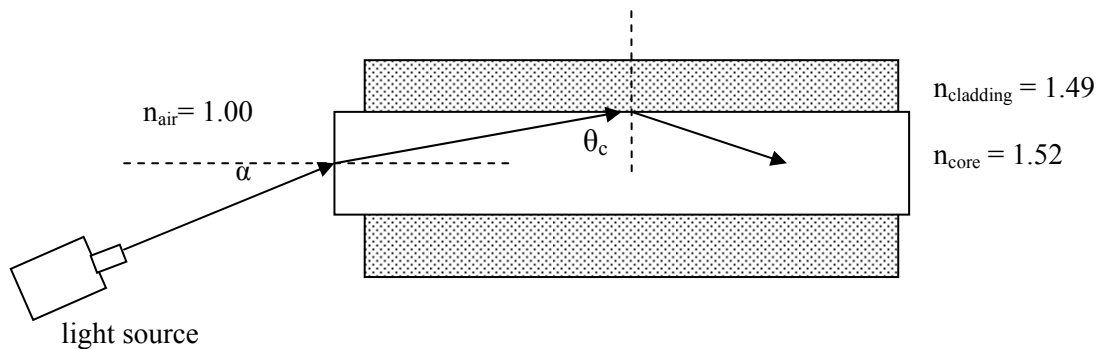
**Figure 3**

**Question 5**

The best estimate for critical angle,  $\theta_c$ , is

- A.  $12.4^\circ$
- B.  $24.8^\circ$
- C.  $78.6^\circ$
- D.  $65.2^\circ$

---

---

2 marks

**Question 6**

The numerical aperture of the fibre is

- A. 0.15
- B. 0.20
- C. 0.25
- D. 0.30

---

---

2 marks

**Question 7**

The acceptance angle,  $\alpha$ , is closest in value to

- A.  $17.5^\circ$
- B.  $16.5^\circ$
- C.  $15.5^\circ$
- D.  $14.5^\circ$

---

---

2 marks

**SECTION B – Detailed study 2 – continued**  
**TURN OVER**

Use the following information to answer Questions 8–11.

The transmission characteristic graph for a single-mode optical fibre is shown in Figure 4.

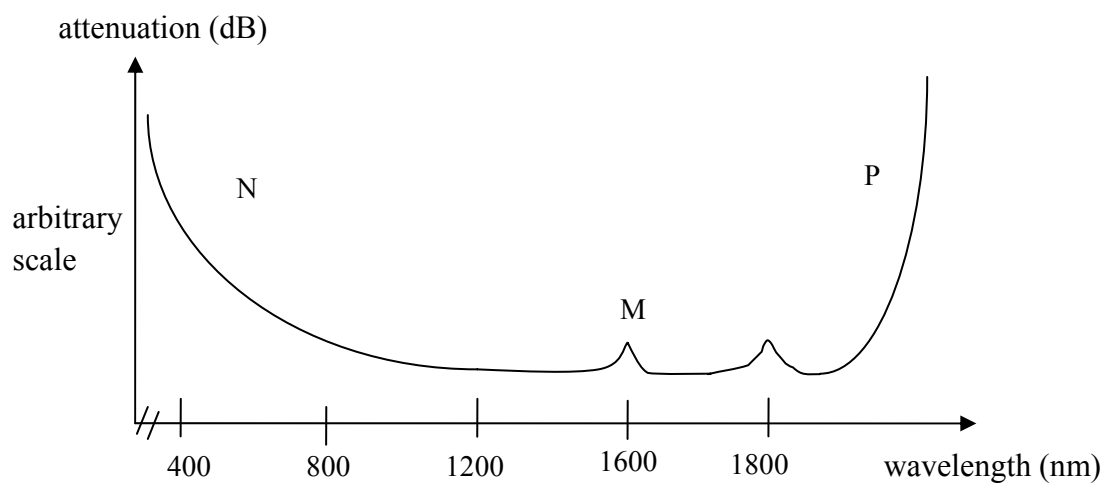

Figure 4

### Question 8

An input signal of 1.1 mW was transmitted over 50 km, and 0.8 mW was received at the other end. The attenuation per km of the signal is closest in magnitude to

- A. 15 dB km<sup>-1</sup>
- B. 1.4 dB km<sup>-1</sup>
- C. 3 dB km<sup>-1</sup>
- D. 0.03 dB km<sup>-1</sup>



---



---



---



---

2 marks



**Question 9**

Which of the following statements best identifies the regions corresponding to the loss mechanism?

- A. N is due to Rayleigh scattering, M due to impurities and P due to absorption by the glass structure.
- B. N is due to impurities, M due to Rayleigh scattering and P due to absorption by the glass structure.
- C. N is due to absorption by the glass structure, M due to Rayleigh scattering and P due to absorption by impurities.
- D. N is due to absorption by the glass structure, M due to absorption by impurities and P due to Rayleigh scattering.

2 marks

**Question 10**

John and Sarah argue about the shape of the graph and the reasons for the peaks. Which of the following statements is the best description of the mechanisms of attenuation in the fibre?

- A. Rayleigh scattering occurs due to the glass structure, which is made of atoms such as Si and O and absorbs light radiation.
- B. Absorption at high wavelengths occurs due to structural irregularities absorbing light energy.
- C. Rayleigh scattering occurs when the wavelength of the transmitted signal is less than the size of the structural irregularities, and absorption occurs due to the interaction of the signal with atoms and bonds.
- D. Impurities in the glass structure absorb both specific and a broad range of wavelengths and this is the predominant reason for attenuation in glass fibres.

2 marks

**Question 11**

Not happy with the single-mode optical fibre they were testing, John and Sarah argue about the other options they could use for transmitting a signal over long distances. Which of the following statements **best** describes **dispersion** in optical fibres?

- A.** Modal dispersion is caused by the different wavelengths in the signal travelling in different paths and can be reduced by using a single mode fibre or a thinner core.
- B.** Material dispersion is caused by different wavelengths in the signal travelling at different speeds and can be reduced by monochromatic laser light. Blue travels slower than red causing a spread of signal.
- C.** Modal dispersion can be significantly reduced by using graded index optical fibre rather than a bunch of several fibres.
- D.** Multimode fibres will allow more data to be transmitted and has lower modal and material dispersion than single mode fibre. However, multimode fibres are more expensive hence not preferred over long distances.

2 marks

Use the following information to answer Questions 12 and 13.

To image a specimen, an optical imaging bundle is made of two different types of fibre in a composite construction, as shown in Figure 5. The outer fibres, O, carry light to the specimen a short distance of 10–20 cm from the observer, and the inner fibres, I, bring the reflected light back for recording of the image.

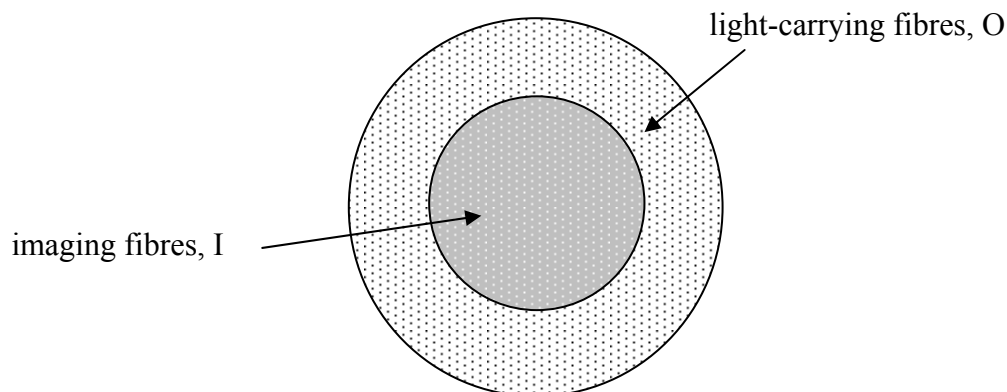

Figure 5

**Question 12**

The preferred choice for the inner fibre would be

- A. step-index single mode
- B. graded index single mode
- C. step-index multi-mode
- D. graded index multi-mode

2 marks

**Question 13**

The resolution of the imaging fibre is 1.5 megapixel. Which array of pixel will give a resolution closest in value to a resolution of 1.5 megapixel? (1 megapixel =  $10^6$  pixels).

- A.  $3870 \times 3870$
- B.  $1225 \times 1225$
- C.  $10^3 \times 10^3$
- D.  $1450 \times 1225$

2 marks

**END OF DETAILED STUDY 2**  
**SECTION B – continued**  
**TURN OVER**

### Detailed study 3 – Sound

Use the following information to answer Questions 1–3.

As shown in Figure 1, a siren sounds a frequency of 800 Hz from the top of a lighthouse sending sound waves in all directions. Joseph and Lim, positioned 80 m and 140 m away respectively, measure the intensity of the sound wave. At a certain time Joseph measures the intensity to be  $3 \times 10^{-5} \text{ Wm}^{-2}$ .

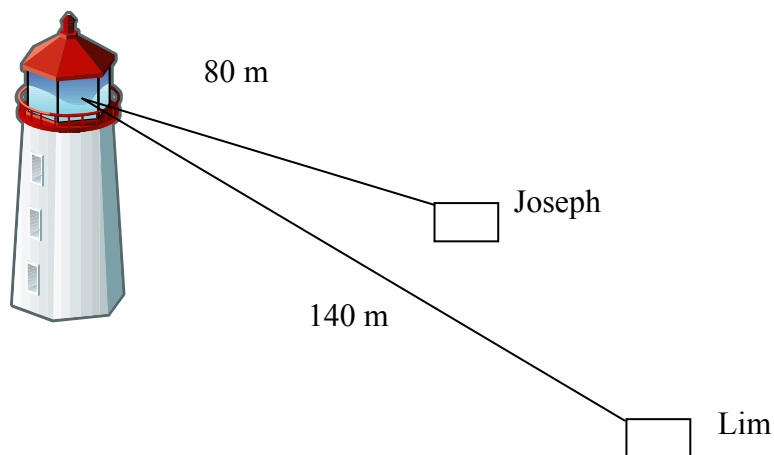

Figure 1

#### Question 1

Which of the following is the best estimate of the power of the siren?

- A. 3 W
- B. 2.4 W
- C. 0.37 W
- D. 24 W



---



---



---

2 marks

**Question 2**

What is the sound intensity level (dB) measured by Lim at 140 m?

- A. 70 dB
- B. 60 dB
- C. 80 dB
- D. 50 dB

---

---

---

---

---

2 marks

**Question 3**

Which of the following is the best answer for the **difference** in dB recorded by Joseph and Lim?

- A. About 6 dB.
- B. About 5 dB.
- C. About 4 dB.
- D. About 3 dB.

---

---

---

---

2 marks

Use the following information to answer Questions 4 and 5.

Gretel notices a howling sound coming from the side of the cottage. She asks Hansel to investigate, who finds that the sound is coming from a pipe just above the window as air blows through it. The pipe is open at both ends and Hansel measures the frequency to be 312 Hz. Take speed of sound to be  $340 \text{ ms}^{-1}$ .

**Question 4**

The length of the pipe is closest in value to

- A. 0.27 m
- B. 0.3 m
- C. 2.1 m
- D. 0.54 m

---

---

---

---

2 marks

**Question 5**

When Hansel closes one end of the pipe tightly with pebbles wrapped in old rags, a different but louder frequency is heard. The frequency of this sound is most likely to be

- A. 157 Hz
- B. 130 Hz
- C. 624 Hz
- D. 225 Hz

---

---

---

2 marks

Use the following information to answer Questions 6–9.

Ahmed and Celina wish to set up some loudspeakers in a performance studio. The response graphs for four loudspeakers, P, Q R, and S, are shown in Figure 2, from which they have to select just one loudspeaker for each performance. On a certain evening's performance there will be speeches and some instrumental music. Speech has a frequency range of 300–600 Hz, whereas instrumental music is about 600–2000 Hz.

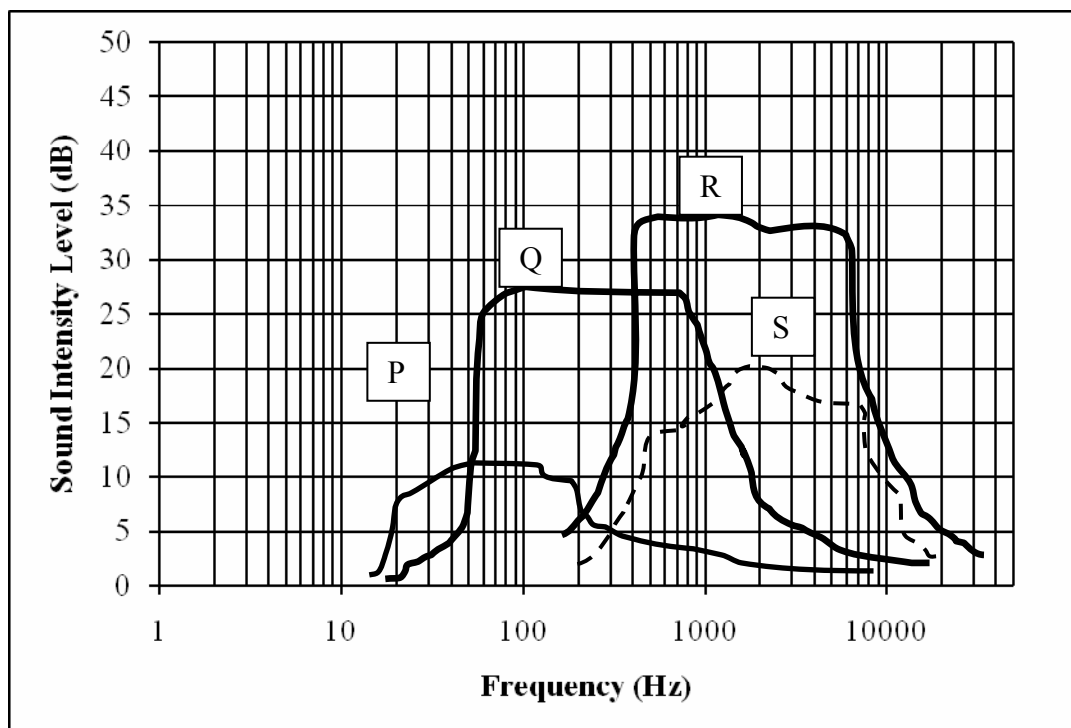

Figure 2

### Question 6

Which of the following statements provides the best suggestion for use of the loudspeakers?

- A. Use Q for both speech and instrumental music.
- B. Use Q for speech and R for instrumental music.
- C. Use R for speech and Q for instrumental music.
- D. Use P for both speech and instrumental music.

2 marks

**Question 7**

The loudspeaker that has the highest fidelity in the range 500–1000 Hz is

- A. P
- B. Q
- C. R
- D. S

2 marks

**Question 8**

Ahmed and Celina remove the baffle from around the loudspeaker R before installing it on a wall such that sound waves can now travel around the room from the front and rear of the loudspeaker. When instrumental music is played through it, what will be the most likely effect of removing the baffle?

- A. The sound will be louder for all frequencies.
- B. The sound will be softer for all frequencies.
- C. The fidelity of the loudspeaker will decrease.
- D. The fidelity of the loudspeaker will increase.

2 marks



**Question 9**

For an instrumental music rehearsal, all loudspeakers and microphones are turned off. Amy and Raj are standing outside the studio door, as shown in Figure 3.

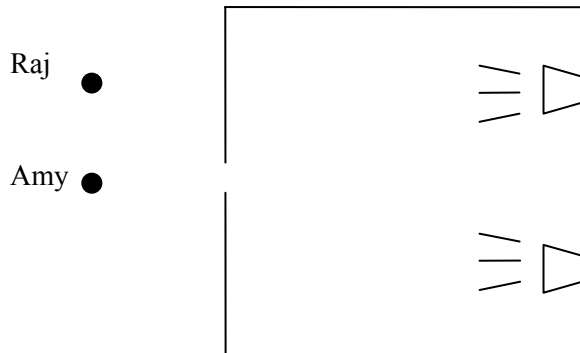
**Figure 3**

Which one of the following statements **best** describes the sound heard by Amy and Raj?

- A. Amy hears more of the higher frequencies than the lower frequencies.
- B. Raj hears all frequencies.
- C. Amy hears all frequencies.
- D. Raj hears more of the higher frequencies than the lower frequencies.

2 marks

Use the following information to answer Questions 10 and 11.

The curves in Figure 4 show the response of a student to different frequencies, each of a pure tone. Each curve represents equal loudness to the student. Note: 1000 Hz is taken as the reference frequency for phons.

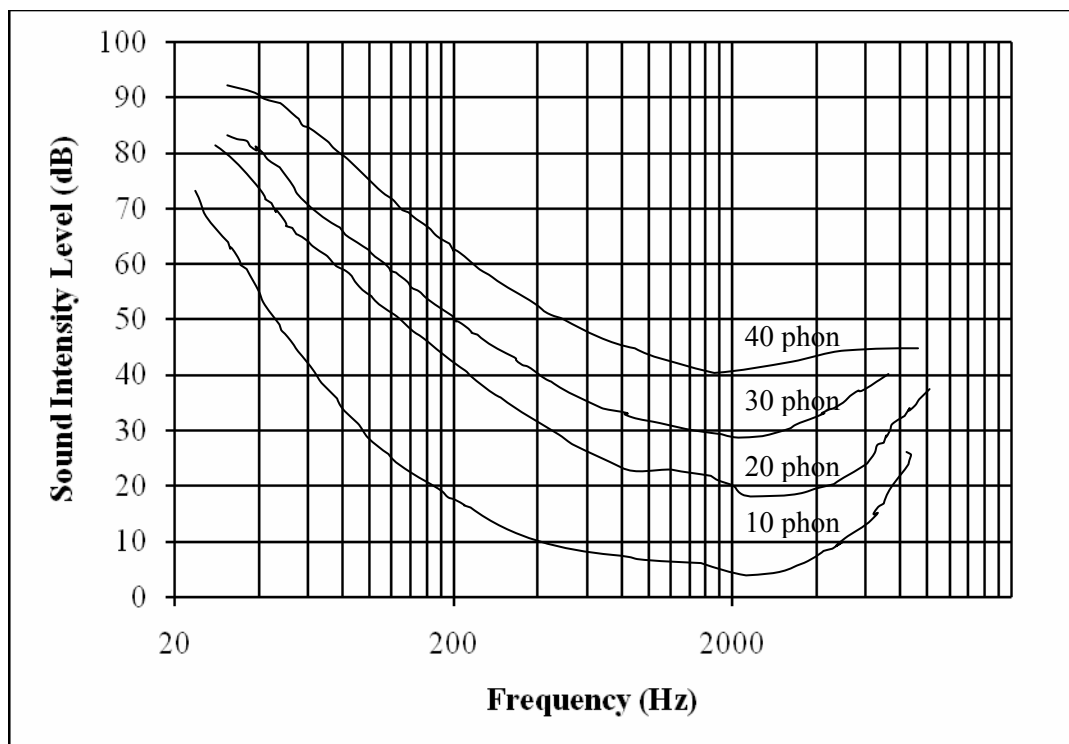

Figure 4

### Question 10

What should be the intensity level of a 500 Hz sound for the student to perceive it as having the same loudness as a 40 dB sound?

- A. About 45 dB.
- B. About 40 dB.
- C. About 30 dB.
- D. About 60 dB.

2 marks

**Question 11**

What is the frequency at which the student perceives a 30 dB sound to have the same loudness as a 40 dB sound?

- A. About 350 Hz.
- B. About 300 Hz.
- C. About 400 Hz.
- D. About 450 Hz.

2 marks

**Question 12**

Which **one or more** of the following statements describes the operation of a moving coil microphone?

- A. It is based on the principle of air pressure affecting the dimensions of a capacitor, thereby affecting the electrical signal.
- B. The inertia of the coil results in good fidelity at high frequency.
- C. The microphone is very sensitive to air pressure and must not be used in open air.
- D. It is based on the principle of electromagnetic induction.

2 marks

**Question 13**

A swimming coach issues an instruction to his student, who is swimming underwater. Which one of the following statements best describes the relationship between speed and frequency of the sound wave in air when compared to water?

- A. The speed of sound is greater in air than in water, whereas the frequency of the sound wave is less in water than in air.
- B. The speed of sound is the same in air and in water. The frequency of the sound wave is greater in air than in water.
- C. The speed of sound is less in water than in air. The frequency of the sound wave is unchanged.
- D. The speed of sound is greater in water than in air. The frequency of the sound wave is unchanged.

2 marks