



INSIGHT
Trial Exam Paper
2009

PHYSICS
Written examination 2

STUDENT NAME:

QUESTION AND ANSWER BOOK

Reading time: 15 minutes
Writing time: 1 hour 30 minutes

Structure of book

<i>Section</i>	<i>Number of questions</i>	<i>Number of questions to be answered</i>	<i>Number of marks</i>
A – Core – Areas of Study			
1. Electric power	18	18	40
2. Interactions of light and matter	11	11	24
B – Detailed Studies			
1. Synchrotron and its applications	13	13	26
OR			
2. Photonics	13	13	26
OR			
3. Sound	13	13	26
Total			90

- Students are permitted to bring the following items into the examination: pens, pencils, highlighters, erasers, sharpeners, rulers and one scientific calculator.
- Students are NOT permitted to bring sheets of paper or white out liquid/tape into the examination.

Materials provided

- The question and answer book of 43 pages, with a separate data sheet.

Instructions

- Write your **name** in the box provided.
- Remove the data sheet during reading time.
- Answer all the questions in the space provided.
- Always show your working where space is provided.
- Where the answer box has a unit printed in it, give your answer in that unit.
- You must answer all questions in English.

Students are NOT permitted to bring mobile phones or any other electronic device into the examination.

This trial examination produced by Insight Publications is NOT an official VCAA paper for the 2009 Physics written examination 2.

This examination paper is licensed to be printed, photocopied or placed on the school intranet and used only within the confines of the purchasing school for examining their students. No trial examination or part thereof may be issued or passed on to any other party including other schools, practising or non-practising teachers, tutors, parents, websites or publishing agencies without the written consent of Insight Publications.

Copyright © Insight Publications 2009

SECTION A – Core

Area of study 1 – Electric power

The following information applies to Questions 1–4.

Figure 1 shows a wire of length 30 cm carrying 2 A of current placed in a uniform magnetic field of magnitude 5 mT in two different orientations, A and B.

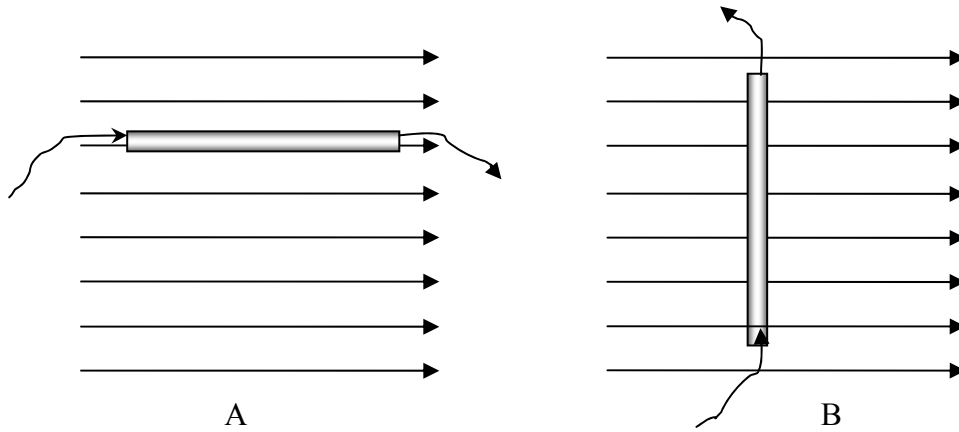

Figure 1

Question 1

What is the magnitude of the magnetic force on the wire in orientation A? Explain your answer.

N

2 marks

Question 2

What is the magnitude and direction of the magnetic force on the wire in orientation B?

N

Direction:

3 marks

Question 3

Explain, referring to magnetic fields, the principle reason **why** the current-carrying conductor experiences the magnetic force when placed in the magnetic field.

2 marks

Question 4

The current in the wire is switched off and the battery replaced with an ammeter. The wire is withdrawn perpendicular to the field at a speed of 10 ms^{-1} . What is the magnitude of the maximum induced current in the wire? Resistance of the wire and the circuit is 5Ω .

mA

2 marks

The following information applies to Questions 5–8.

Farmer Jo obtains electricity for his farmhouse by a hydro-electric generator, making use of a natural waterfall in the valley below (Figure 2). The generator produces 6000 W at V_{RMS} of 1200 V. There is one transformer near his farmhouse that steps down the voltage to suit his needs.

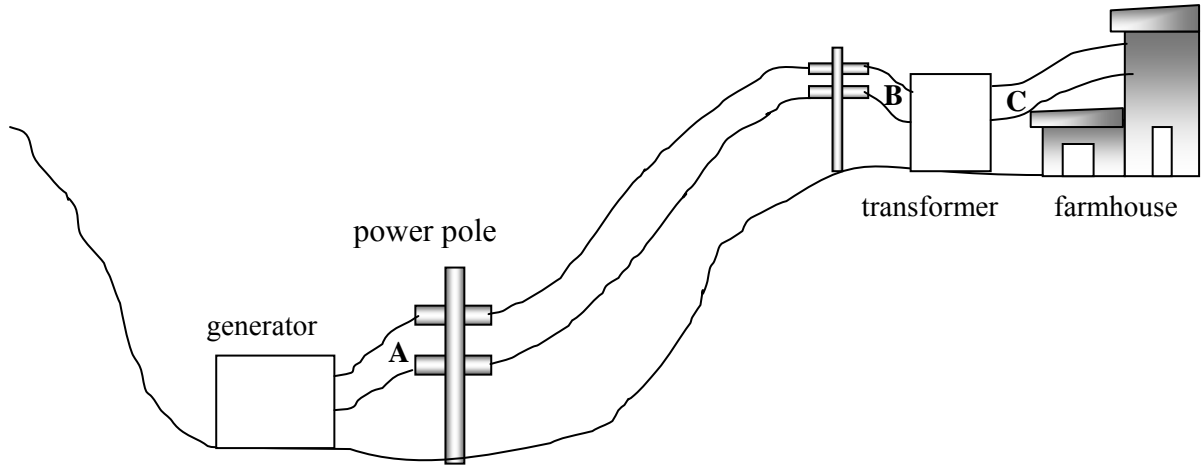

Figure 2

Question 5

What is the RMS current in the transmission lines at location A?

A

2 marks

Question 6

The total resistance of the transmission lines between locations A and B is 5Ω . What is the RMS voltage supplied to the transformer at location B?

V

3 marks

Question 7

Farmer Jo receives $235 V_{\text{RMS}}$ at location C as a result of the transformer action between locations B and C. What is the ratio of the turns in the primary coil to the secondary coil of the transformer?

: 1

2 marks

Question 8

Farmer Jo's friend Jim recommends installing the transformer near the generator at location A in order to save power, but Farmer Jo wishes to keep it at its current location. The transformer could be, if needed, switched around so its primary and secondary ends are reversed. Using appropriate calculation, compare and contrast the effects of locating the transformer at location A compared with its current location at C, and determine who is correct. Assume the transformer to be 100% efficient.

3 marks

The following information applies to Questions 9 and 10.

A flat coil of 10 turns and dimensions $2\text{ cm} \times 2\text{ cm}$ is placed between the poles of a magnet and its behaviour studied as it rotates around the axis. The experimental apparatus is shown in Figure 3.

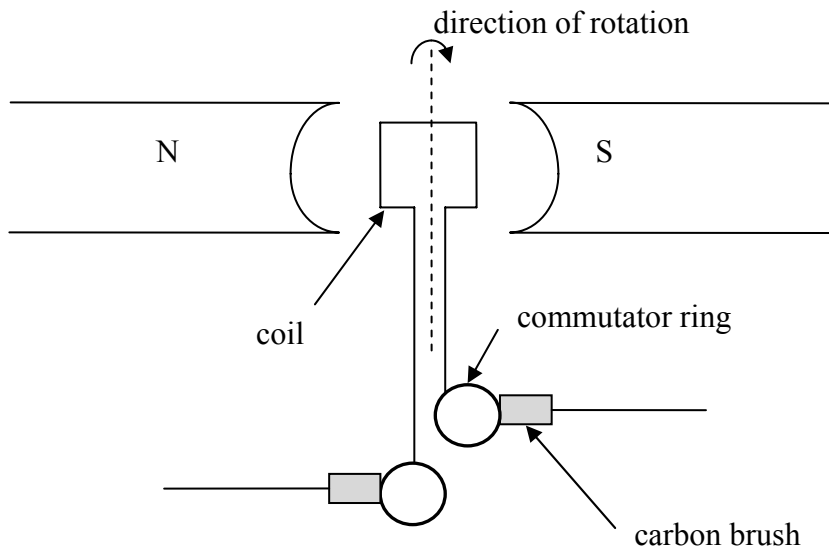

Figure 3

Starting from a certain position at time $t = 0\text{ s}$, the variation of flux with time is shown in Figure 4 for the first 0.04 s .

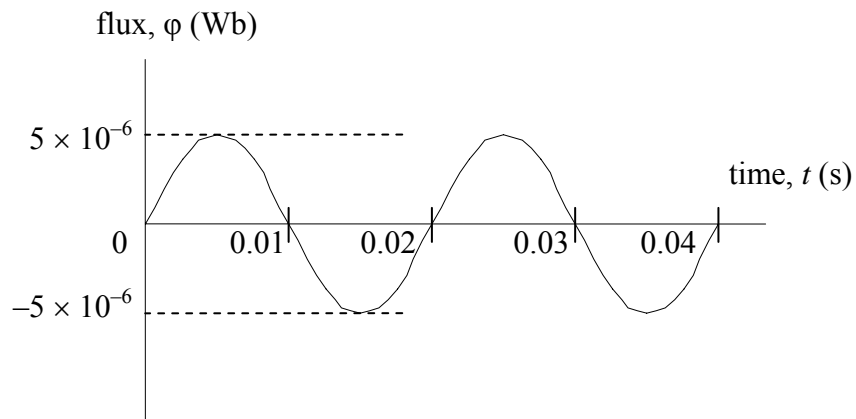

Figure 4

Question 9

What is the magnitude of the maximum magnetic field strength experienced by the coil?

T

2 marks

Question 10

A CRO measures the voltage output across the commutator as a function of time. On the axes sketched in Figure 5, which shows the original variation of flux with time, sketch the CRO voltage signal for time $t = 0$ to $t = 0.04$ s. Show your working and add a suitable scale on the y-axis.

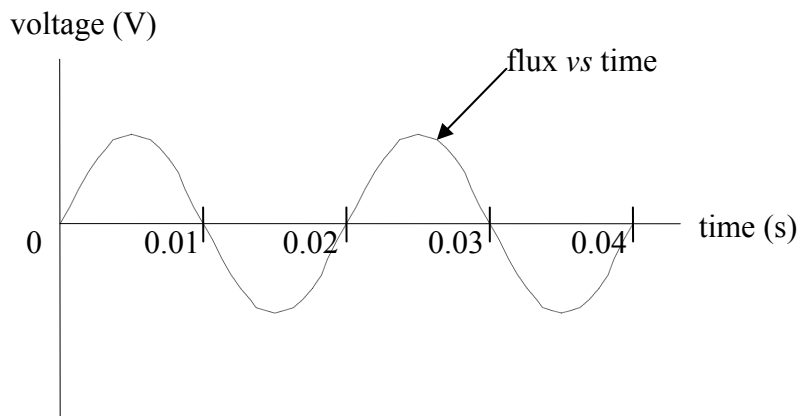
**Figure 5**

3 marks

The following information applies to Questions 11 and 12.

A 20-turn flat coil DC motor of sides 3 cm^2 is spinning at a frequency of 50 Hz in a uniform magnetic field of strength 5 mT. The current in the coil is measured to be 3 A.

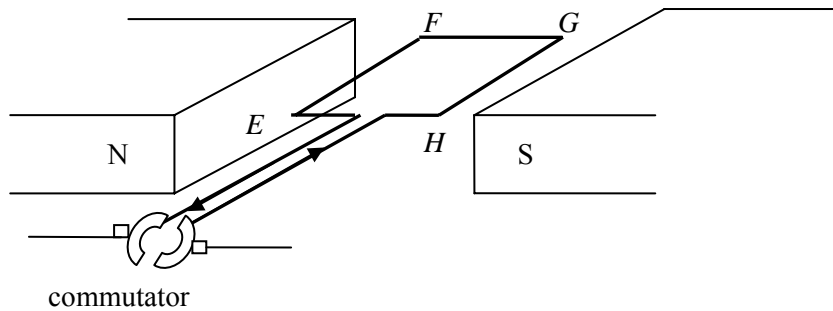

Figure 6

Question 11

Starting from the position shown in Figure 6, what is the magnitude of the magnetic force on side EF at time $t = 0\text{ s}$?

N

2 marks

Question 12

Looking at the coil from the location of the commutator, will the motor spin clockwise or anticlockwise? Explain your answer.

2 marks

The following information applies to Questions 13 and 14.

A permanent magnet is set into oscillations by the use of a spring such that the north pole of the magnet enters a solenoid briefly and then oscillates about its mean position. It is assumed that the motion of the magnet is not influenced measurably by air friction.

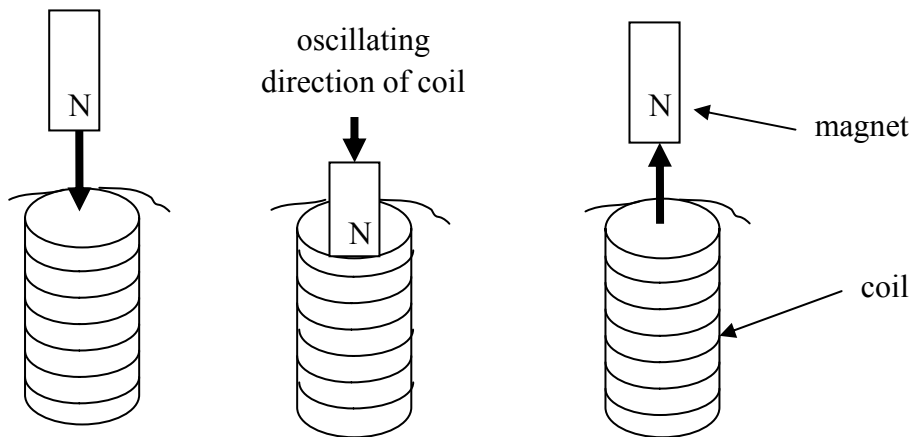

Figure 7

Question 13

What is the direction of induced current as the magnet inserts into the solenoid? Explain your answer.

2 marks

Question 14

Explain what would be the effect of doubling the frequency of the magnet's oscillation on the induced EMF.

2 marks

Question 15

An electromagnet is shown in Figure 8. Sketch **three** significant lines of magnetic field created in and around the electromagnet due to the current.

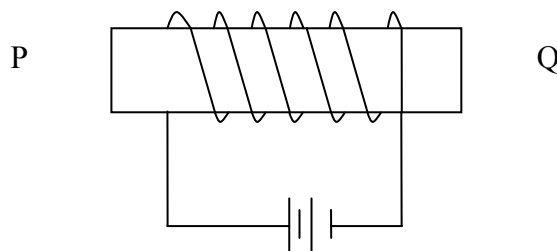
**Figure 8**

2 marks

The following information applies to Questions 16–18.

A light bulb is lit up using a 9 V DC battery and a **small** amount of current, as shown in Figure 9.

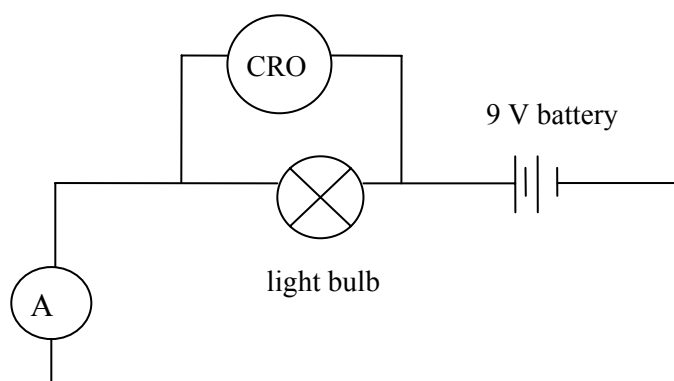
**Figure 9**

Question 16

Which of the following graphs, A to D, best represents the lamp's voltage versus current graph?

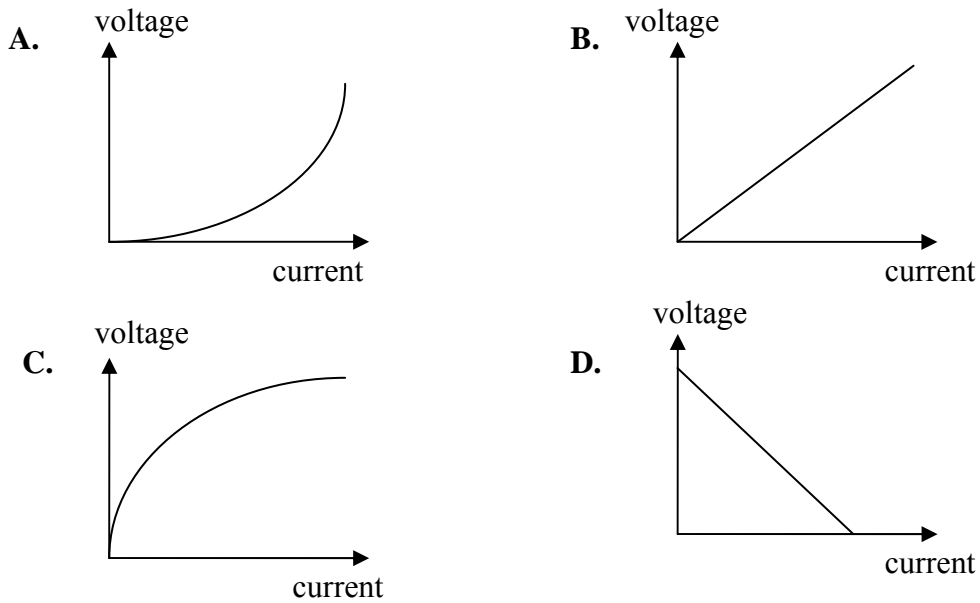
**Figure 10**

2 marks

Question 17

Which of the following graphs, A to D, best represents the lamp's power loss versus current?

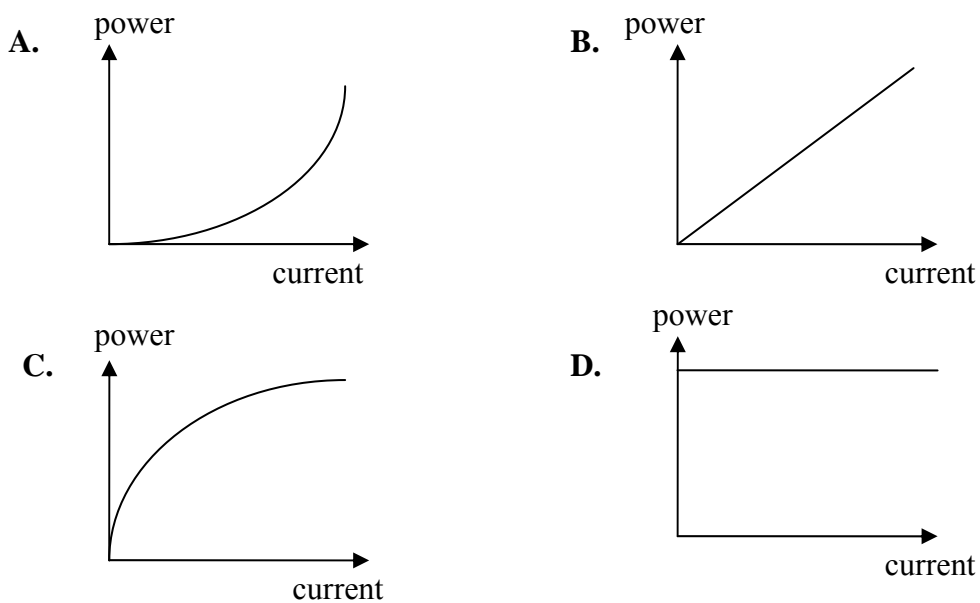
**Figure 11**

2 marks

SECTION A – Area of study 1 – continued
TURN OVER

Question 18

The 9 V DC battery is now replaced by a variable AC power supply. What AC peak voltage will give the same lighting effect of the light bulb as the 9 V DC battery?

V

2 marks

Area of study 2 – Interactions of light and matter

Use the following information to answer Questions 1–4.

A certain gas is being researched when in its ground state. Its energy level diagram is shown in Figure 1.

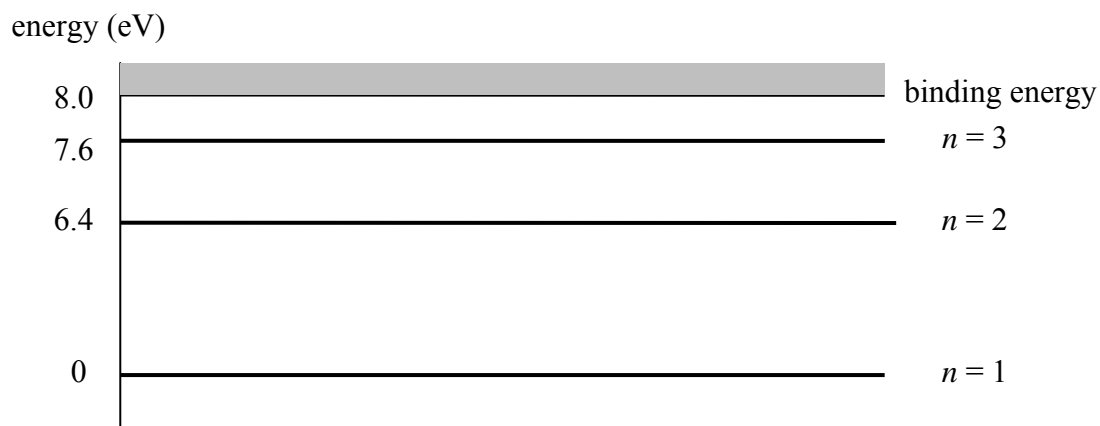

Figure 1

Question 1

What would be the longest wavelength expected in the absorption spectra of the gas in its ground state?

nm

2 marks

Question 2

Estimate one wavelength that exists in the emission spectra but not in the absorption spectra for the gas when in its ground state.

nm

2 marks

SECTION A – Area of study 2 – continued
TURN OVER

A sample of this gas, which is enclosed in a glass vessel at room temperature, is subjected to a monochromatic beam as part of a research project. When Steven shines a monochromatic beam of 8.3 eV onto this gas, electrons are released and an absorption line is also seen in the absorption spectra. However, when Casey shines a monochromatic beam of 7.4 eV, no electrons are released and no lines are seen in the absorption spectra.

Question 3

Explain, with reference to energy levels of the gas, why Steven saw an absorption line whereas Casey did not.

2 marks

Question 4

What will be the maximum kinetic energy of the electrons released in Steven's experiments?

J

2 marks

Use the following information to answer Question 5.

A beam of electrons is generated in an electron gun and travels through a vacuum chamber under an accelerating voltage of 12 000 V. The beam is intercepted by a mono-atomic crystal, which is acting as a diffraction grating.

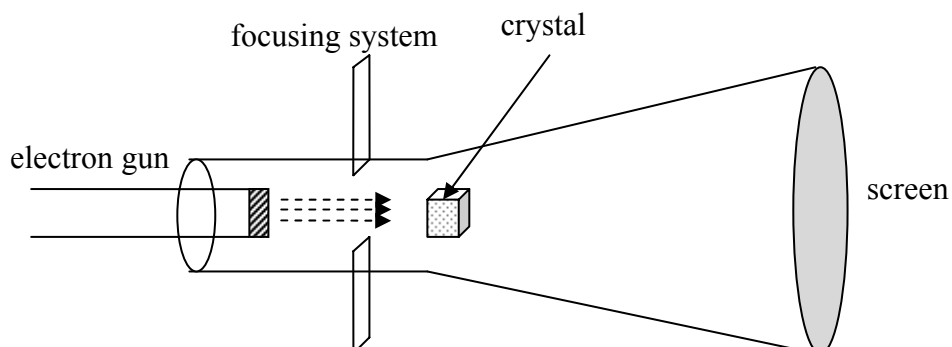

Figure 2

Question 5

Calculate the de Broglie wavelength of the electrons at the instant they strike the crystal.

3 marks

Use the following information to answer Questions 6 and 7.

A laser light beam, which is monochromatic and coherent, and of wavelength 450 nm, is shone through a pair of narrow slits, 0.15 mm apart, as part of an investigation of Young's experiment, as shown in Figure 3. A pattern of high-intensity lines separated by regions of darkness are observed on the screen, which is placed 2.5 m away from the slits.

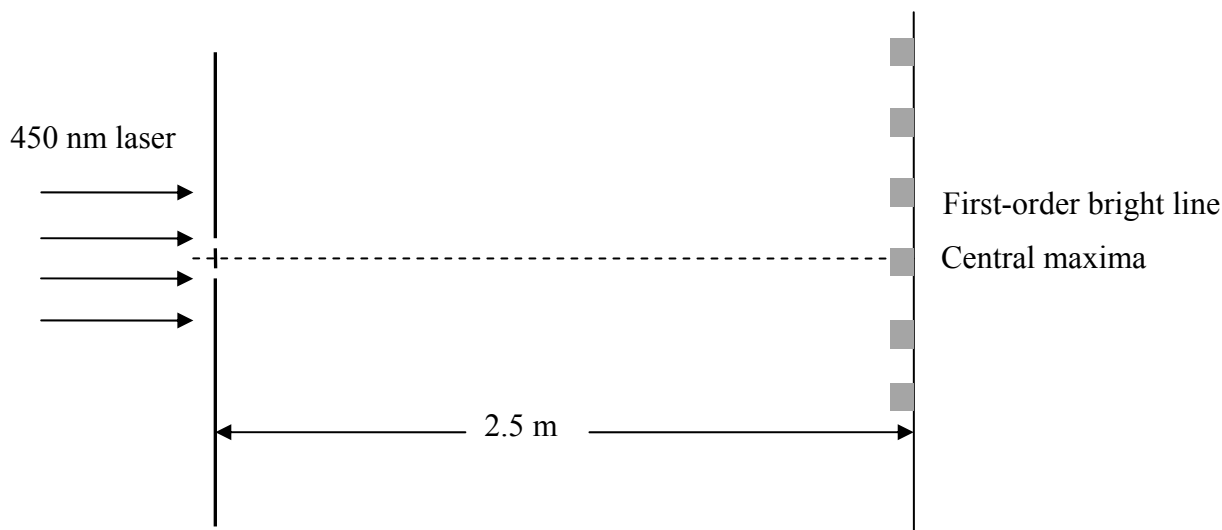

Figure 3

Question 6

What will be the distance of the first-order bright intensity line from the centre of the central maxima?

mm

2 marks

Question 7

If one of the slits is covered up, estimate the **maximum** width of the single slit that is needed in order to see significant diffraction. Explain the reasoning for your answer.

nm

2 marks

Use the following information to answer Questions 8–11.

The photoelectric properties of a metal were studied by using a photoelectric cell where the metal is used as a photocell and the light source has monochromatic but variable frequency. Such a light source could be a tuneable laser. The data were plotted in two different ways and are shown in Figures 4a and 4b. In Figure 4a, the magnitude of photocurrent is plotted against stopping voltage, V_s , for a certain frequency ' f_1 '. In Figure 4b, the maximum kinetic energy of the emitted photoelectron is graphed against a range of frequencies.

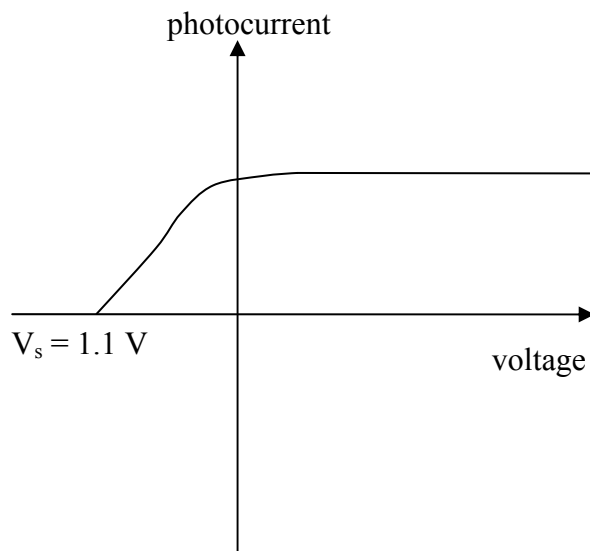

Figure 4a

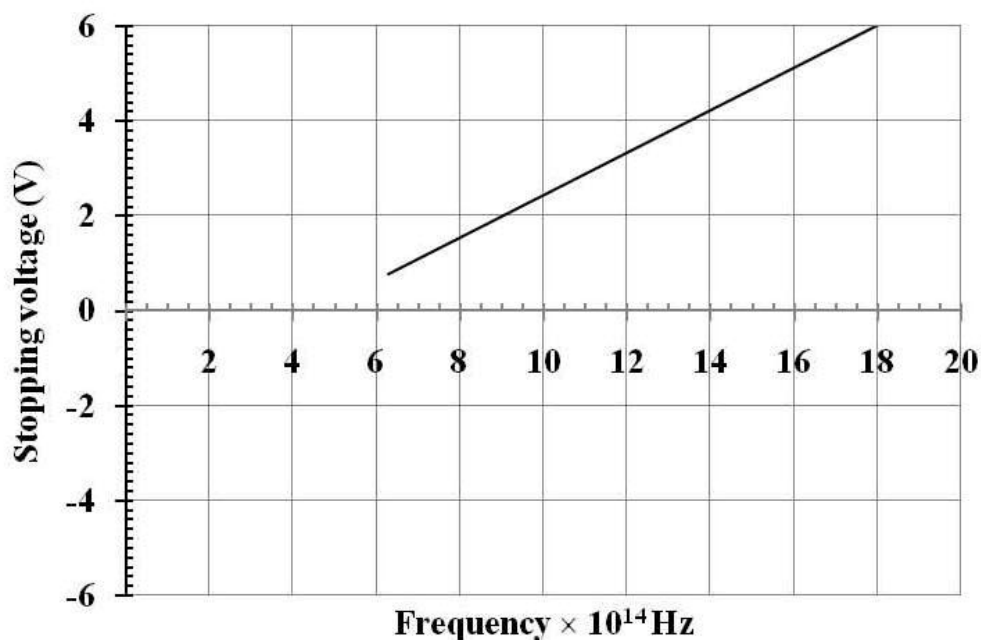

Figure 4b

Question 8

Use the graphical data from Figures 4a and 4b to determine the frequency of light, ' f_1 ', used in this experiment.

Hz

2 marks

Question 9

Which of the graphs, A to D, best represents the outcome when the frequency of the incident light beam is increased **and** the intensity of the incident light beam is decreased? The original light beam (dashed line) is shown for reference. Explain your choice of answer.

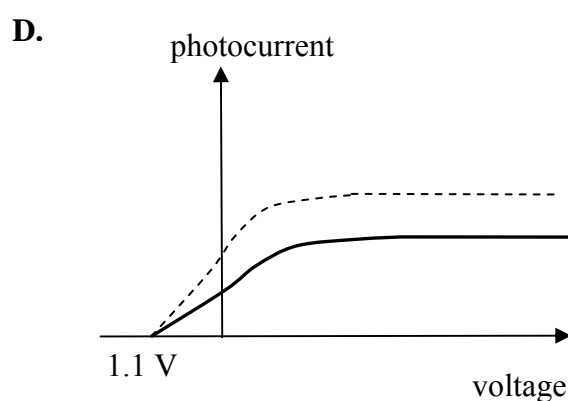
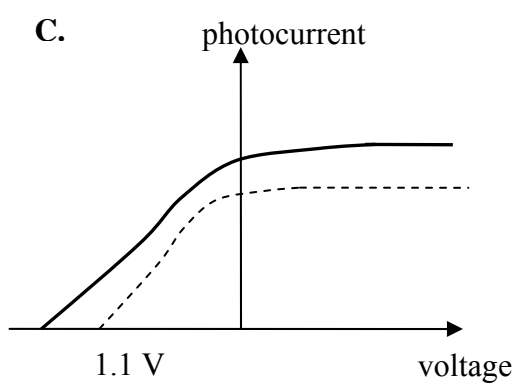
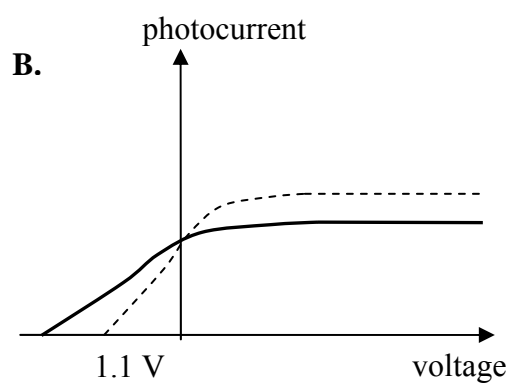
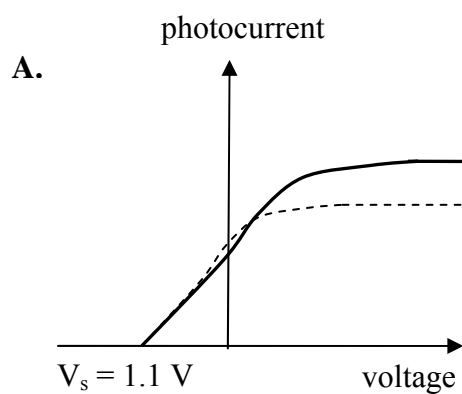

--

2 marks

Question 10

From the graphical data of Figures 4a and 4b, determine the work function of the metal. Show your working.

eV

2 marks

Question 11

Using the graphical data from Figures 4a and 4b, what is the value of Planck's constant? You must show your working.

Js

3 marks

**END OF SECTION A
TURN OVER**

SECTION B – Detailed studies**Detailed study 1 – Synchrotron and its applications**

An electron gun is used to produce electrons of different velocities by appropriately tuning the accelerating electron. A construction of a typical electron gun is shown in Figure 1.

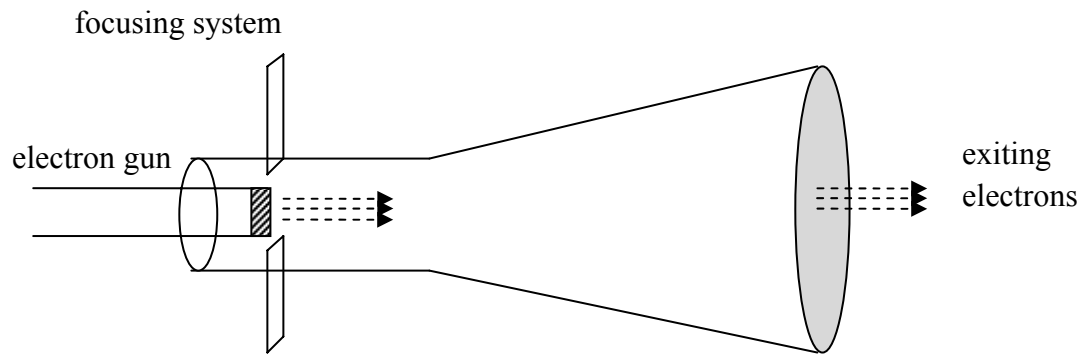

Figure 1

Question 1

What is the voltage necessary to generate electrons of kinetic energy 1 GeV?

- A. 1 gigavolt
- B. 1.6 gigavolt
- C. 1.6×10^{-19} V
- D. 1.6×10^{-13} V

2 marks

Question 2

What is the speed of electrons upon exiting from the gun when the accelerating voltage is 2500 V?

- A. About $2 \times 10^7 \text{ ms}^{-1}$.
- B. About $2.5 \times 10^6 \text{ ms}^{-1}$.
- C. About $3 \times 10^8 \text{ ms}^{-1}$.
- D. About $3 \times 10^7 \text{ ms}^{-1}$.

2 marks

Question 3

An electron with velocity $3 \times 10^6 \text{ ms}^{-1}$ enters a uniform magnetic field of $5 \times 10^{-3} \text{ T}$, as shown in Figure 2. The force on the electron is best described as

- A. $1.5 \times 10^4 \text{ N}$ to the right.
- B. $2.4 \times 10^{-15} \text{ N}$ to the left.
- C. $2.4 \times 10^{-15} \text{ N}$ to the right.
- D. $1.5 \times 10^4 \text{ N}$ to the left.

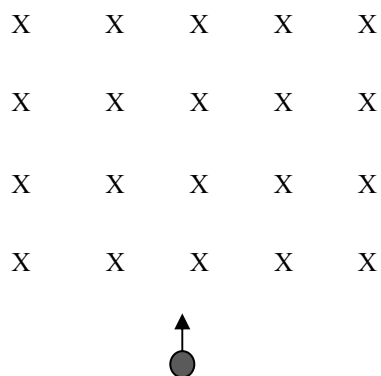
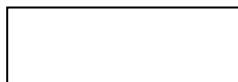

Figure 2



2 marks

Use the following information to answer Questions 4–7.

The following statements, A to D, refer to the functioning and design of one component of the Australian synchrotron.

- A. Electrons are kept in a circular path for hours at a time and close to the speed of light. Synchrotron light is emitted when electrons change direction. Loss of energy due to synchrotron radiation is replenished by RF chambers.
- B. Electrons are bent into a circular path by magnets positioned at right angles to the electron beam. Energy of the electrons is increased as they travel through built-in RF chambers.
- C. It produces electrons and accelerates them across a potential difference in a high vacuum chamber, using focusing systems to narrow the beam.
- D. Situated within the storage ring and consisting of alternating magnetic poles, this component increases the brightness of the synchrotron light.

For Questions 4–7, identify the component of the Australian synchrotron with its function described in statements A, B, C or D.

Question 4

The 'linac':

2 marks

Question 5

The circular booster:

2 marks

Question 6

The storage ring:

2 marks

Question 7

Wigglers:

2 marks

Use the following information to answer Questions 8 and 9.

Crystal diffraction analysis is carried out on a sample of a newly developed crystalline material using a 1.5 keV X-ray beam. In the first experiment, the X-ray beam, with energy 1.5 keV, is produced by a normal laboratory X-ray tube. In the second experiment on the same crystalline material, the X-ray beam is produced by a synchrotron.

Question 8

In the context of X-ray diffraction, which of the following statements best describes the advantage of X-rays produced by the synchrotron over those produced by a normal laboratory X-ray tube?

- A.** The beam produced by the synchrotron is coherent, which results in a better resolution.
- B.** The beam produced by the synchrotron has a much narrower range of wavelengths, which results in a better resolution.
- C.** The beam produced by the synchrotron has a higher intensity and a low divergence, which contributes to a better resolution.
- D.** The beam produced by the synchrotron has very high energy.

2 marks

SECTION B – Detailed study 1 – continued
TURN OVER

Question 9

A crystal of the new material shows a diffraction image with the 1.5 keV X-ray beam. A graph of X-ray diffracted intensity versus angle shows a sharp line at 28° , as shown in Figure 3.

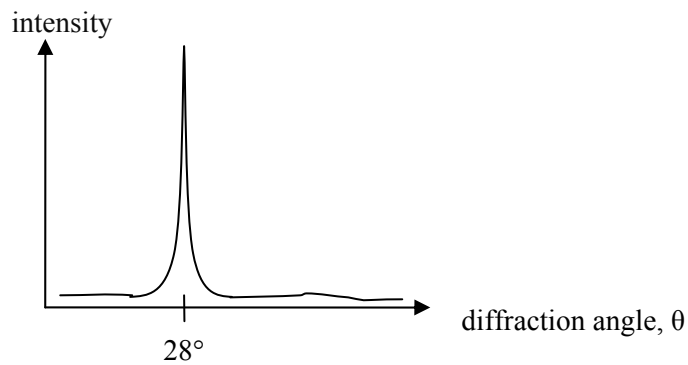
**Figure 3**

The inter-atomic distance is most likely to be

- A. 3.1×10^{-10} m
- B. 2.4×10^{-9} m
- C. 8.8×10^{-10} m
- D. 8.3×10^{-10} m

2 marks

Question 10

As electrons bend in a circular path in a synchrotron, the photon beam is produced

- A. tangent to the path of the electron beam.
- B. perpendicular to the path of the electron beam and directed towards the centre of the circular path.
- C. along the path of the electron beam.
- D. perpendicular to the path of the electron beam and directed away from the centre of the circular path.

2 marks

Question 11

The radiation produced in the Australian synchrotron is called 'synchronous'. Which one of the following is the best explanation of this definition?

- A. All radiation produced has the same energy and, hence, is of a single wavelength. This allows for exceptionally detailed analysis of materials.
- B. Electrons that release radiation are of nearly equal energy as they travel in circular paths in the storage ring. The radiation they release upon bending consists of a range of wavelengths.
- C. The radiation produced is very intense and monochromatic.
- D. All radiation produced is in phase.

2 marks

Use the following information to answer Questions 12 and 13.

A photon of wavelength 0.08 nm scatters from a graphite sample within an X-ray tube, as shown in Figure 4. A scattered photon of wavelength 0.09 nm and an electron are detected, consistent with the Compton effect.

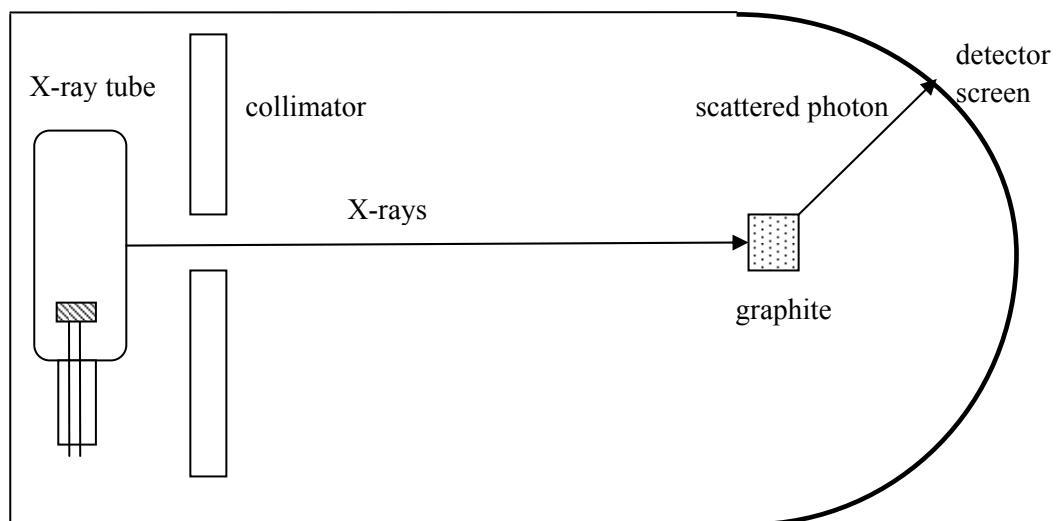

Figure 4

Question 12

What is the kinetic energy of the electron? Show your working.

- A. 1530 eV
- B. 100 eV
- C. 1600 eV
- D. 1725 eV

2 marks

Question 13

Which one of the following statements best contrasts Compton and Thomson scattering?

- A.** Compton scattering is an *elastic* collision between an incident photon and an electron and there is no wavelength shift in the photon. Thomson scattering is an *inelastic* collision and there is a wavelength shift in the scattered photon.
- B.** Thomson scattering is an *elastic* collision between an incident photon and an electron and there is no wavelength shift in the photon. Compton scattering is an *inelastic* collision and there is a wavelength shift in the scattered photon.
- C.** Thomson scattering is an *inelastic* collision between an incident photon and an electron and there is a wavelength shift in the photon. Compton scattering is an *elastic* collision and there is no wavelength shift in the scattered photon.
- D.** Thomson scattering is an *inelastic* collision between an incident photon and an electron and there is no wavelength shift in the photon. Compton scattering is an *elastic* collision and there is a wavelength shift in the scattered photon.

2 marks

END OF DETAILED STUDY 1
SECTION B – continued
TURN OVER

Detailed study 2 – Photonics

Use the following information to answer Questions 1 and 2.

A piece of iron at room temperature is heated until it glows white hot. The emitted colour taken at various temperatures, P, Q, R and S, is shown in Figure 1.

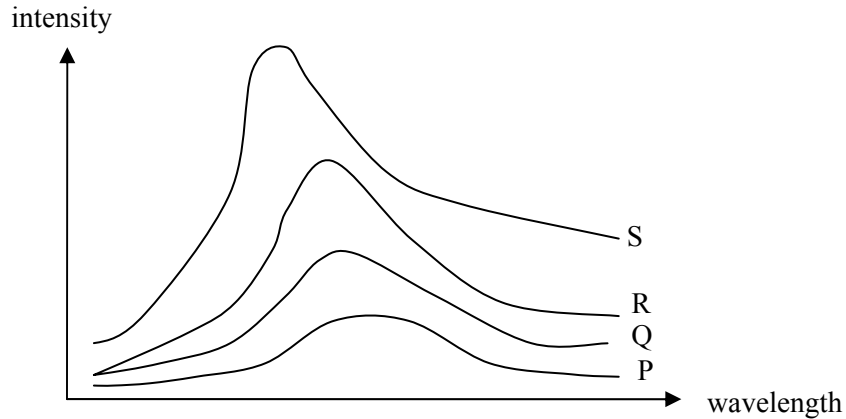

Figure 1

Question 1

The magnitude of temperature decreases in the sequence

- A. $S > Q > R > P$
- B. $S > R > Q > P$
- C. $P > Q > R > S$
- D. $P > R > Q > S$

2 marks

Question 2

Which of the following statements best describes the principal cause of the spectrum?

- A. Thermal motion of electrons.
- B. A wide variety of sources, including accelerating electrons and protons.
- C. Energy transformations in the nucleus.
- D. Chemical changes in the material.

2 marks

Use the following information to answer Questions 3 and 4.

A newly developed semiconductor LED has a band gap of 1.7 eV. To research its light-emitting properties the LED is connected in a circuit, as shown in Figure 2.

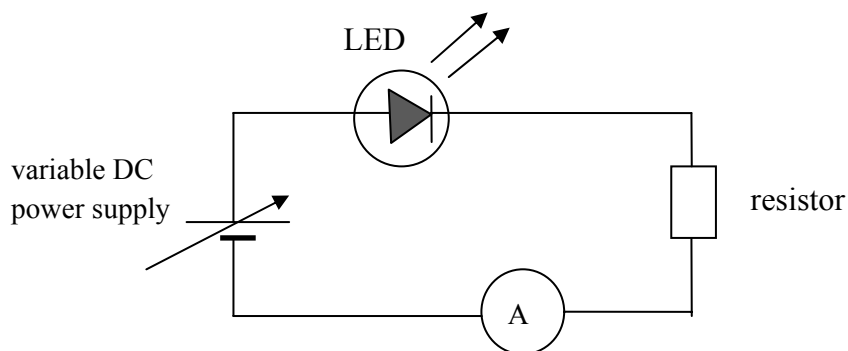
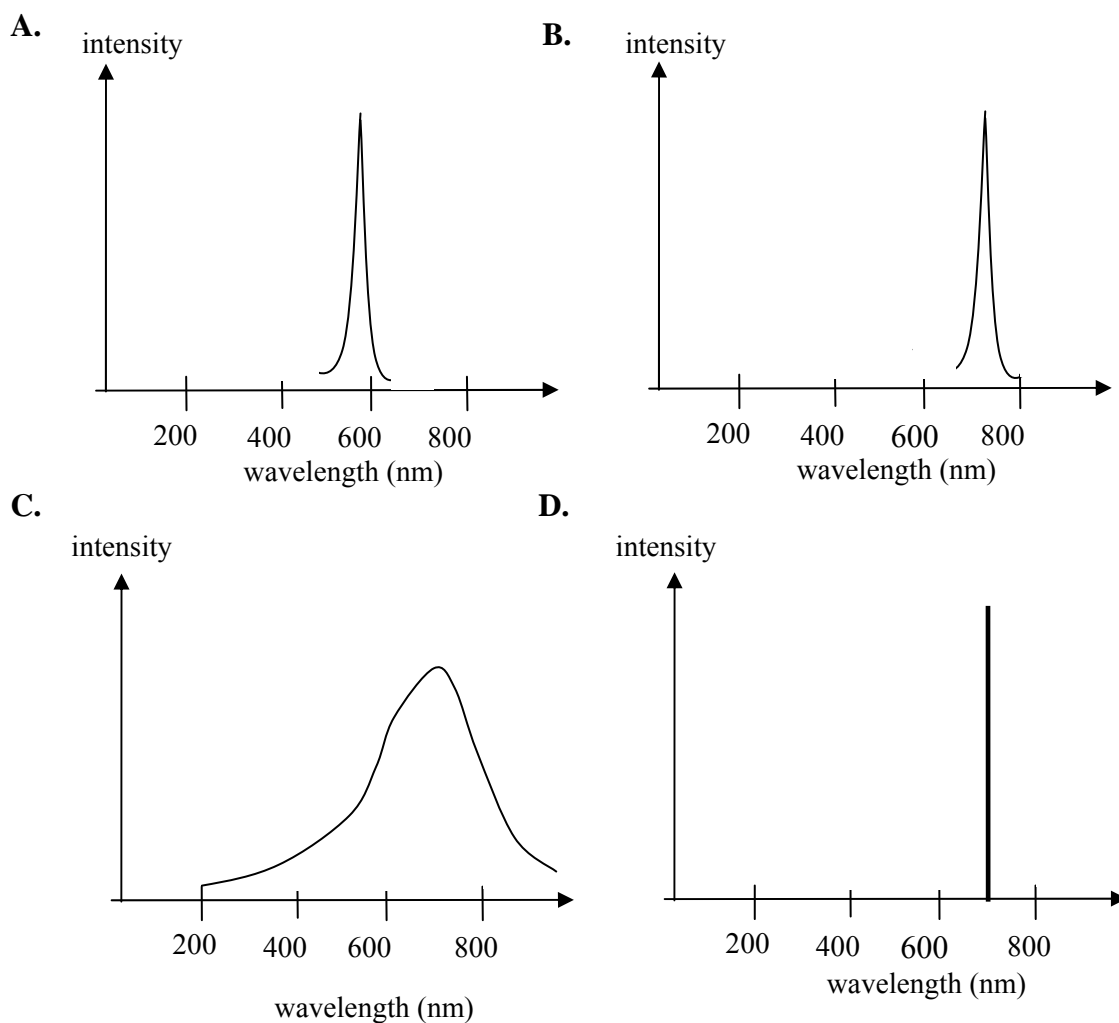

Figure 2

Question 3

Which of the following is the most likely shape of the spectrum emitted by the LED?



2 marks

SECTION B – Detailed study 2 – continued
TURN OVER

Question 4

The experiment is repeated with another sample of the LED material but is now found to be emitting a **lower** intensity, although the average wavelength does not change. Which of the following is the most likely cause?

- A. The battery is providing a higher voltage than previously.
- B. The battery is providing a lower voltage than previously.
- C. Some impurities are present in the LED.
- D. The LED is connected in reverse bias.

2 marks

Use the following information to answer Questions 5–7.

A ray of light enters a step-index optical fibre from air and undergoes total internal reflection at the core-cladding interface, as shown in Figure 3. The refractive index of air, core and cladding are, respectively, 1.00, 1.52 and 1.49.

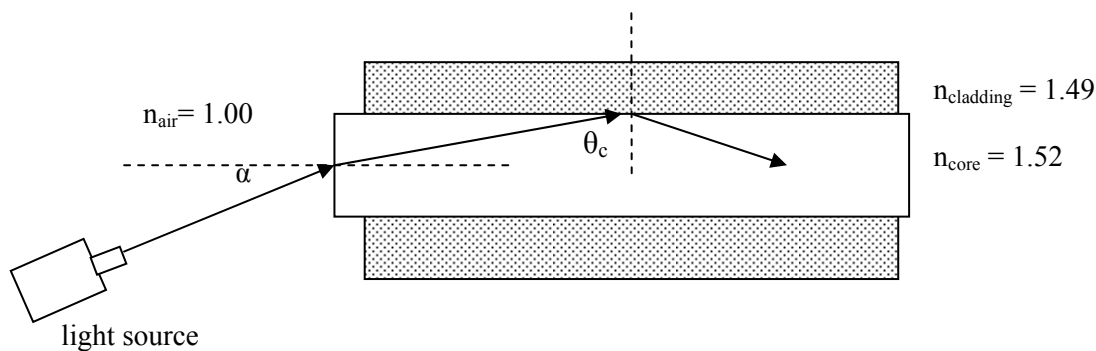
**Figure 3**

Question 5

The best estimate for critical angle, θ_c , is

- A. 12.4°
- B. 24.8°
- C. 78.6°
- D. 65.2°

2 marks

Question 6

The numerical aperture of the fibre is

- A. 0.15
- B. 0.20
- C. 0.25
- D. 0.30

2 marks

Question 7

The acceptance angle, α , is closest in value to

- A. 17.5°
- B. 16.5°
- C. 15.5°
- D. 14.5°

2 marks

SECTION B – Detailed study 2 – continued
TURN OVER

Use the following information to answer Questions 8–11.

The transmission characteristic graph for a single-mode optical fibre is shown in Figure 4.

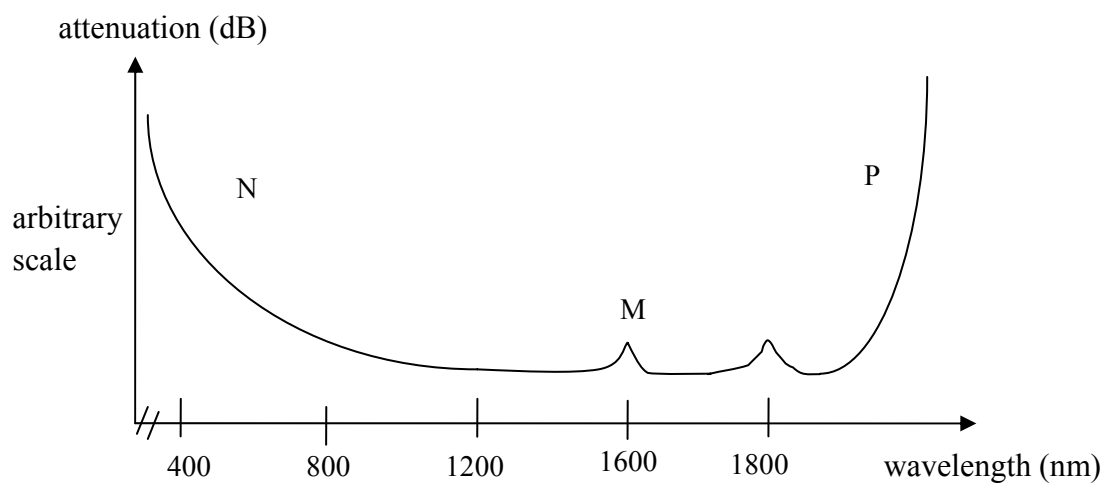

Figure 4

Question 8

An input signal of 1.1 mW was transmitted over 50 km, and 0.8 mW was received at the other end. The attenuation per km of the signal is closest in magnitude to

- A. 15 dB km⁻¹
- B. 1.4 dB km⁻¹
- C. 3 dB km⁻¹
- D. 0.03 dB km⁻¹

2 marks

Question 9

Which of the following statements best identifies the regions corresponding to the loss mechanism?

- A. N is due to Rayleigh scattering, M due to impurities and P due to absorption by the glass structure.
- B. N is due to impurities, M due to Rayleigh scattering and P due to absorption by the glass structure.
- C. N is due to absorption by the glass structure, M due to Rayleigh scattering and P due to absorption by impurities.
- D. N is due to absorption by the glass structure, M due to absorption by impurities and P due to Rayleigh scattering.

2 marks

Question 10

John and Sarah argue about the shape of the graph and the reasons for the peaks. Which of the following statements is the best description of the mechanisms of attenuation in the fibre?

- A. Rayleigh scattering occurs due to the glass structure, which is made of atoms such as Si and O and absorbs light radiation.
- B. Absorption at high wavelengths occurs due to structural irregularities absorbing light energy.
- C. Rayleigh scattering occurs when the wavelength of the transmitted signal is less than the size of the structural irregularities, and absorption occurs due to the interaction of the signal with atoms and bonds.
- D. Impurities in the glass structure absorb both specific and a broad range of wavelengths and this is the predominant reason for attenuation in glass fibres.

2 marks

Question 11

Not happy with the single-mode optical fibre they were testing, John and Sarah argue about the other options they could use for transmitting a signal over long distances. Which of the following statements **best** describes **dispersion** in optical fibres?

- A.** Modal dispersion is caused by the different wavelengths in the signal travelling in different paths and can be reduced by using a single mode fibre or a thinner core.
- B.** Material dispersion is caused by different wavelengths in the signal travelling at different speeds and can be reduced by monochromatic laser light. Blue travels slower than red causing a spread of signal.
- C.** Modal dispersion can be significantly reduced by using graded index optical fibre rather than a bunch of several fibres.
- D.** Multimode fibres will allow more data to be transmitted and has lower modal and material dispersion than single mode fibre. However, multimode fibres are more expensive hence not preferred over long distances.

2 marks

Use the following information to answer Questions 12 and 13.

To image a specimen, an optical imaging bundle is made of two different types of fibre in a composite construction, as shown in Figure 5. The outer fibres, O, carry light to the specimen a short distance of 10–20 cm from the observer, and the inner fibres, I, bring the reflected light back for recording of the image.

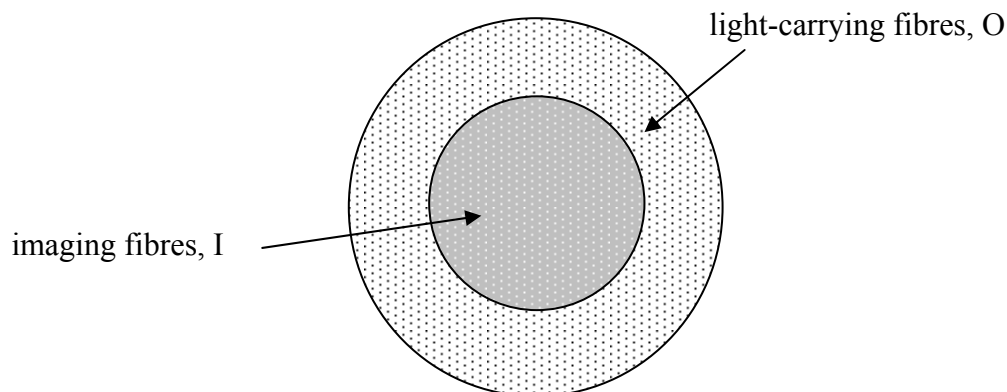

Figure 5

Question 12

The preferred choice for the inner fibre would be

- A. step-index single mode
- B. graded index single mode
- C. step-index multi-mode
- D. graded index multi-mode

2 marks

Question 13

The resolution of the imaging fibre is 1.5 megapixel. Which array of pixel will give a resolution closest in value to a resolution of 1.5 megapixel? (1 megapixel = 10^6 pixels).

- A. 3870×3870
- B. 1225×1225
- C. $10^3 \times 10^3$
- D. 1450×1225

2 marks

END OF DETAILED STUDY 2
SECTION B – continued
TURN OVER

Detailed study 3 – Sound

Use the following information to answer Questions 1–3.

As shown in Figure 1, a siren sounds a frequency of 800 Hz from the top of a lighthouse sending sound waves in all directions. Joseph and Lim, positioned 80 m and 140 m away respectively, measure the intensity of the sound wave. At a certain time Joseph measures the intensity to be $3 \times 10^{-5} \text{ Wm}^{-2}$.

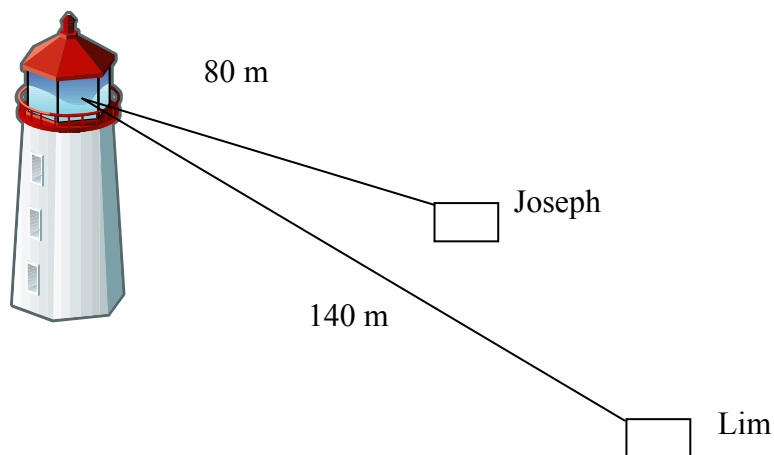

Figure 1

Question 1

Which of the following is the best estimate of the power of the siren?

- A. 3 W
- B. 2.4 W
- C. 0.37 W
- D. 24 W

2 marks

Question 2

What is the sound intensity level (dB) measured by Lim at 140 m?

- A. 70 dB
- B. 60 dB
- C. 80 dB
- D. 50 dB

2 marks

Question 3

Which of the following is the best answer for the **difference** in dB recorded by Joseph and Lim?

- A. About 6 dB.
- B. About 5 dB.
- C. About 4 dB.
- D. About 3 dB.

2 marks

Use the following information to answer Questions 4 and 5.

Gretel notices a howling sound coming from the side of the cottage. She asks Hansel to investigate, who finds that the sound is coming from a pipe just above the window as air blows through it. The pipe is open at both ends and Hansel measures the frequency to be 312 Hz. Take speed of sound to be 340 ms^{-1} .

Question 4

The length of the pipe is closest in value to

- A. 0.27 m
- B. 0.3 m
- C. 2.1 m
- D. 0.54 m

2 marks

Question 5

When Hansel closes one end of the pipe tightly with pebbles wrapped in old rags, a different but louder frequency is heard. The frequency of this sound is most likely to be

- A. 157 Hz
- B. 130 Hz
- C. 624 Hz
- D. 225 Hz

2 marks

Use the following information to answer Questions 6–9.

Ahmed and Celina wish to set up some loudspeakers in a performance studio. The response graphs for four loudspeakers, P, Q R, and S, are shown in Figure 2, from which they have to select just one loudspeaker for each performance. On a certain evening's performance there will be speeches and some instrumental music. Speech has a frequency range of 300–600 Hz, whereas instrumental music is about 600–2000 Hz.

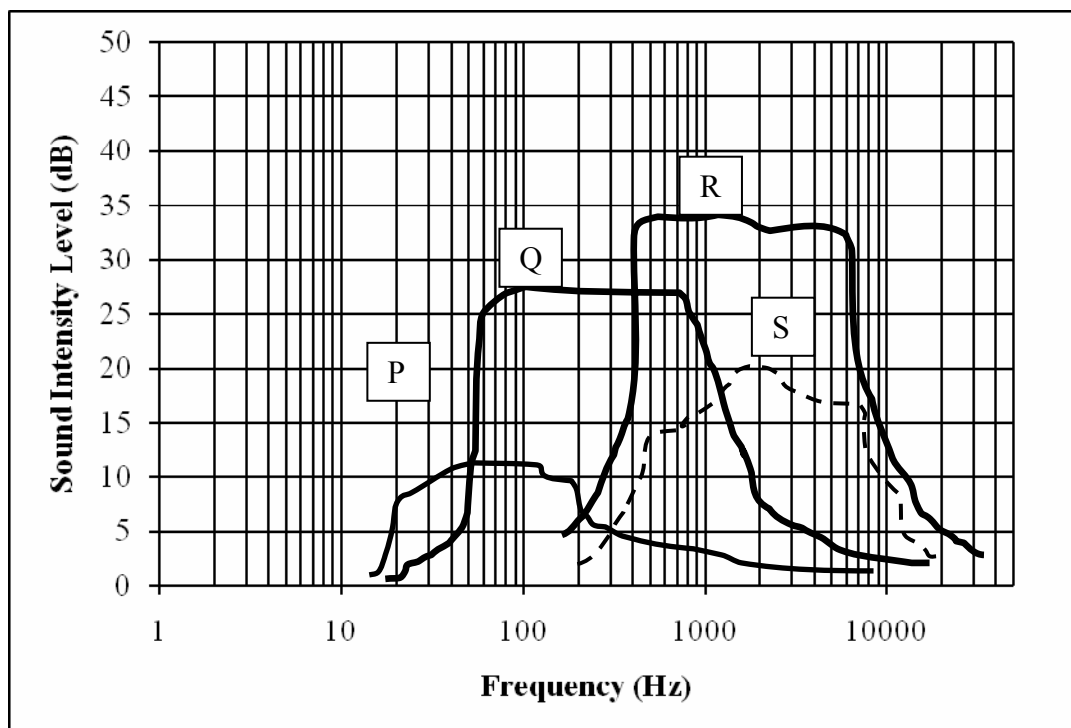

Figure 2

Question 6

Which of the following statements provides the best suggestion for use of the loudspeakers?

- A. Use Q for both speech and instrumental music.
- B. Use Q for speech and R for instrumental music.
- C. Use R for speech and Q for instrumental music.
- D. Use P for both speech and instrumental music.

2 marks

Question 7

The loudspeaker that has the highest fidelity in the range 500–1000 Hz is

- A. P
- B. Q
- C. R
- D. S

2 marks

Question 8

Ahmed and Celina remove the baffle from around the loudspeaker R before installing it on a wall such that sound waves can now travel around the room from the front and rear of the loudspeaker. When instrumental music is played through it, what will be the most likely effect of removing the baffle?

- A. The sound will be louder for all frequencies.
- B. The sound will be softer for all frequencies.
- C. The fidelity of the loudspeaker will decrease.
- D. The fidelity of the loudspeaker will increase.

2 marks

Question 9

For an instrumental music rehearsal, all loudspeakers and microphones are turned off. Amy and Raj are standing outside the studio door, as shown in Figure 3.

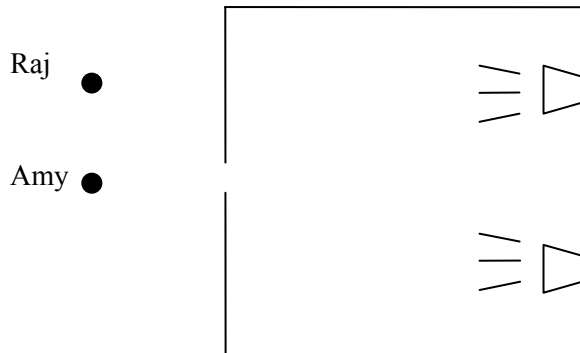
**Figure 3**

Which one of the following statements **best** describes the sound heard by Amy and Raj?

- A. Amy hears more of the higher frequencies than the lower frequencies.
- B. Raj hears all frequencies.
- C. Amy hears all frequencies.
- D. Raj hears more of the higher frequencies than the lower frequencies.

2 marks

Use the following information to answer Questions 10 and 11.

The curves in Figure 4 show the response of a student to different frequencies, each of a pure tone. Each curve represents equal loudness to the student. Note: 1000 Hz is taken as the reference frequency for phons.

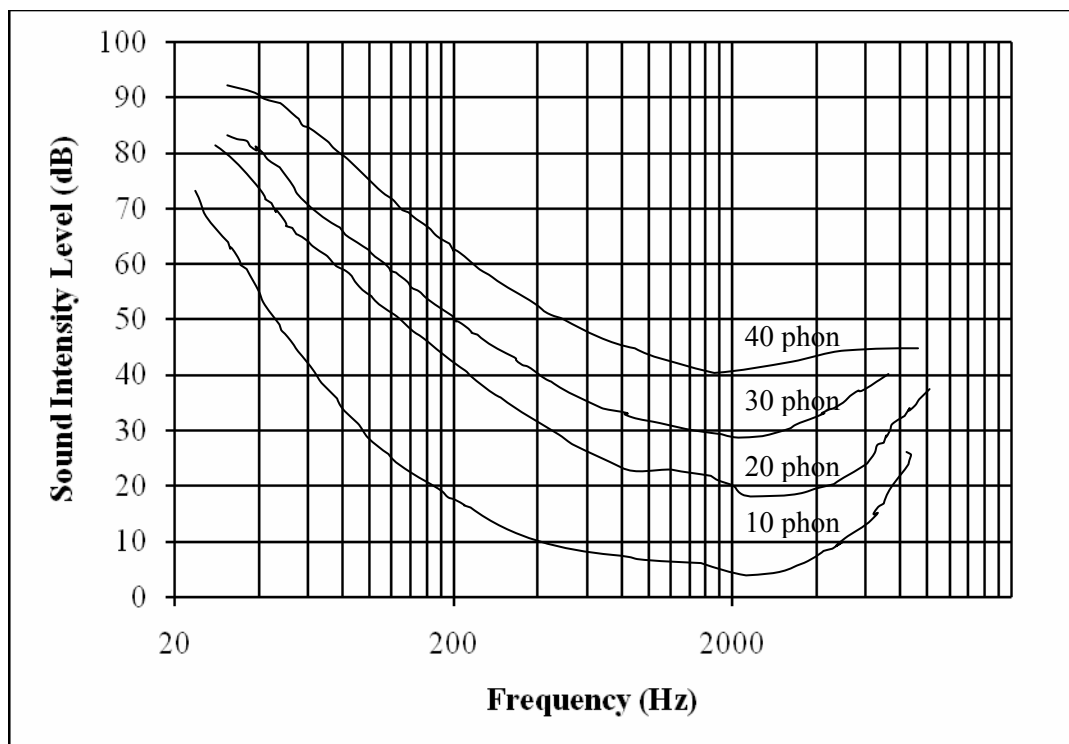

Figure 4

Question 10

What should be the intensity level of a 500 Hz sound for the student to perceive it as having the same loudness as a 40 dB sound?

- A. About 45 dB.
- B. About 40 dB.
- C. About 30 dB.
- D. About 60 dB.

2 marks

Question 11

What is the frequency at which the student perceives a 30 dB sound to have the same loudness as a 40 dB sound?

- A. About 350 Hz.
- B. About 300 Hz.
- C. About 400 Hz.
- D. About 450 Hz.

2 marks

Question 12

Which **one or more** of the following statements describes the operation of a moving coil microphone?

- A. It is based on the principle of air pressure affecting the dimensions of a capacitor, thereby affecting the electrical signal.
- B. The inertia of the coil results in good fidelity at high frequency.
- C. The microphone is very sensitive to air pressure and must not be used in open air.
- D. It is based on the principle of electromagnetic induction.

2 marks

Question 13

A swimming coach issues an instruction to his student, who is swimming underwater. Which one of the following statements best describes the relationship between speed and frequency of the sound wave in air when compared to water?

- A. The speed of sound is greater in air than in water, whereas the frequency of the sound wave is less in water than in air.
- B. The speed of sound is the same in air and in water. The frequency of the sound wave is greater in air than in water.
- C. The speed of sound is less in water than in air. The frequency of the sound wave is unchanged.
- D. The speed of sound is greater in water than in air. The frequency of the sound wave is unchanged.

2 marks



INSIGHT
Trial Exam Paper

2009
PHYSICS
Written examination 2

Worked Solutions

This book presents:

- worked solutions, giving you a series of points to show you how to work through the questions
- mark allocation details

This trial examination produced by Insight Publications is NOT an official VCAA paper for the 2009 Physics written examination 2.

This examination paper is licensed to be printed, photocopied or placed on the school intranet and used only within the confines of the purchasing school for examining their students. No trial examination or part thereof may be issued or passed on to any other party including other schools, practising or non-practising teachers, tutors, parents, websites or publishing agencies without the written consent of Insight Publications.

Copyright © Insight Publications 2009

This page is blank

SECTION A – Core**Area of study 1 – Electric power**

The following information applies to Questions 1–4.

Figure 1 shows a wire of length 30 cm carrying 2 A of current placed in a uniform magnetic field of magnitude 5 mT in two different orientations, A and B.

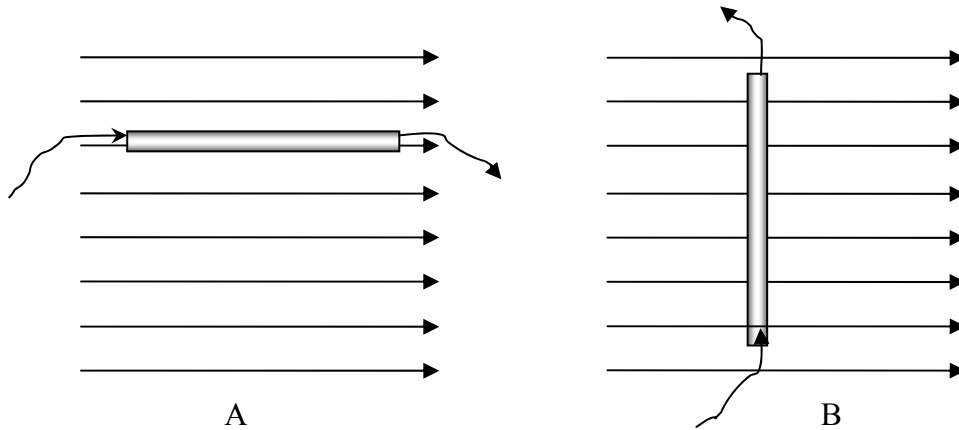

Figure 1

Question 1

What is the magnitude of the magnetic force on the wire in orientation A? Explain your answer.

Worked solution

$$F = BIl \times \sin \theta$$

Since the conductor is parallel to magnetic field, $\theta = 0$; hence, force on it is zero.

0 N

2 marks

Mark allocation

- 1 mark for correct answer.
- 1 mark for explanation.

Question 2

What is the magnitude and direction of the magnetic force on the wire in orientation B?

Worked solution

$$F = BIl \times \sin \theta$$

$$F = 5 \times 10^{-3} \times 2 \times 0.3$$

$$= 3 \times 10^{-3} \text{ N}$$

Using the Right Hand rule, direction of force is into the page.

$3 \times 10^{-3} \text{ N}$

Direction: Into the page

3 marks

Mark allocation

- 1 mark for correct values substituted into correct formula.
- 1 mark for calculating the magnitude of force correctly.
- 1 mark for correct direction.

Question 3

Explain, referring to magnetic fields, the principle reason **why** the current-carrying conductor experiences the magnetic force when placed in the magnetic field.

Worked solution

The self-magnetic field of the current-carrying conductor interacts with the external magnetic field. Vector addition of the two fields results in a net field and the conductor experiences a force to realign it in the direction of the net field. The force experienced is the force due to the magnetic field that is referred to in the question.

2 marks

Mark allocation

- 1 mark for explaining the role of the two magnetic fields.
- 1 mark for drawing a successful conclusion.

Question 4

The current in the wire is switched off and the battery replaced with an ammeter. The wire is withdrawn perpendicular to the field at a speed of 10 ms^{-1} . What is the magnitude of the maximum induced current in the wire? Resistance of the wire and the circuit is 5Ω .

Worked solution

$$\begin{aligned} \text{Induced current} &= \frac{\text{Induced EMF}}{\text{Resistance}} = \frac{Bvl}{R} \\ &= \frac{5 \times 10^{-3} \times 10 \times 0.3}{5} = 3 \text{ mA} \end{aligned}$$

3 mA

2 marks

Mark allocation

- 1 mark for correct choice of formula.
- 1 mark for correct answer.

Tips

- *Take care to avoid mathematical errors when powers of 10 are involved.*
- *Draw a diagram for estimating relative direction of field and conductor, if not given.*

The following information applies to Questions 5–8.

Farmer Jo obtains electricity for his farmhouse by a hydro-electric generator, making use of a natural waterfall in the valley below (Figure 2). The generator produces 6000 W at V_{RMS} of 1200 V . There is one transformer near his farmhouse that steps down the voltage to suit his needs.

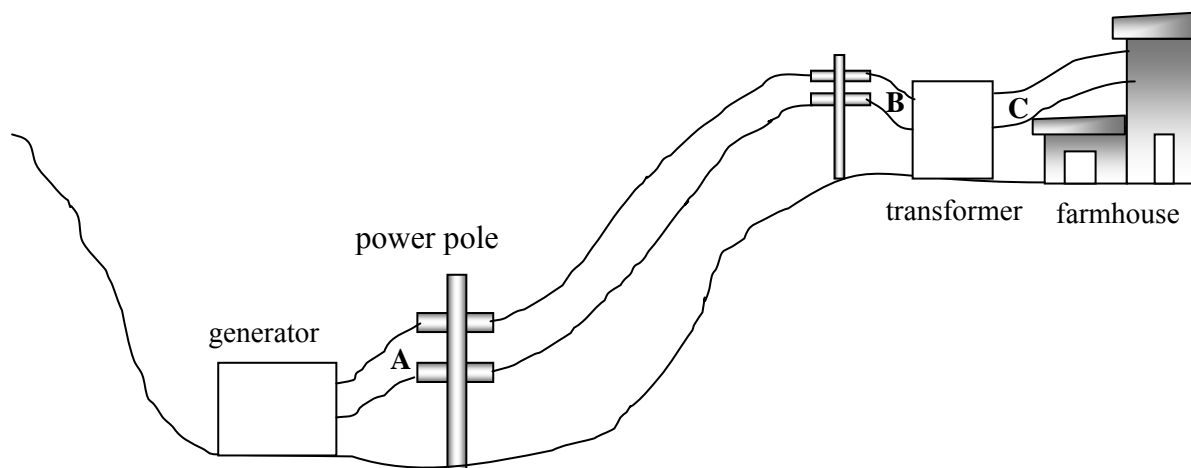
**Figure 2**

Question 5

What is the RMS current in the transmission lines at location A?

Worked solution

$$I = \frac{P}{V} = \frac{6000}{1200}$$

$$I_{\text{RMS}} = 5 \text{ A}$$

5 A

2 marks

Mark allocation

- 1 mark for correct use of the I, P, V relationship.
- 1 mark for correct answer.

Question 6

The total resistance of the transmission lines between locations A and B is 5Ω . What is the RMS voltage supplied to the transformer at location B?

Worked solution

$$P_{\text{loss}} \text{ between A and B} = I^2 R = 5^2 \times 5 = 125 \text{ W}$$

$$\therefore P_{\text{B}} = 6000 - 125 = 5875 \text{ W}$$

$$\therefore V_{\text{B, RMS}} = \frac{5875}{5} = 1175 \text{ V}$$

1175 V

3 marks

Mark allocation

- 1 mark for calculating power loss.
- 1 mark for calculating power at location B.
- 1 mark for estimating correct voltage at location B.

Question 7

Farmer Jo receives $235 \text{ V}_{\text{RMS}}$ at location C as a result of the transformer action between locations B and C. What is the ratio of the turns in the primary coil to the secondary coil of the transformer?

Worked solution

$$\frac{V_{\text{primary}}}{V_{\text{secondary}}} = \frac{N_{\text{primary}}}{N_{\text{secondary}}} = \frac{1175}{235} = \frac{5}{1}$$

5 : 1

2 marks

Mark allocation

- 1 mark for correct values substituted into correct formula.
- 1 mark for correct answer.

Question 8

Farmer Jo's friend Jim recommends installing the transformer near the generator at location A in order to save power, but Farmer Jo wishes to keep it at its current location. The transformer could be, if needed, switched around so its primary and secondary ends are reversed. Using appropriate calculation, compare and contrast the effects of locating the transformer at location A compared with its current location at C, and determine who is correct. Assume the transformer to be 100% efficient.

Worked solution

If the transformer is installed at location A as a step-up transformer, then

$$\frac{V_{\text{primary}}}{V_{\text{secondary}}} = \frac{N_{\text{primary}}}{N_{\text{secondary}}} = \frac{1}{5} = \frac{1200}{V_{\text{secondary}}}$$

Therefore, the voltage provided at location A = 6000 V.

Current in the lines = 1 A

Therefore, power loss $I^2R = 1^2 \times 5 = 5 \text{ W}$

Voltage at location B = 6000 – 5 = 5995 V.

Installation of the transformer at location A as a step-up transformer saves more power.

3 marks

Mark allocation

- 1 mark for appropriate use of transformer equation.
- 1 mark for calculation of power loss.
- 1 mark for correct conclusion.

Tips

- *Show calculations clearly when asked to show working.*
- *Identify clearly primary and secondary quantities.*

The following information applies to Questions 9 and 10.

A flat coil of 10 turns and dimensions $2\text{ cm} \times 2\text{ cm}$ is placed between the poles of a magnet and its behaviour studied as it rotates around the axis. The experimental apparatus is shown in Figure 3.

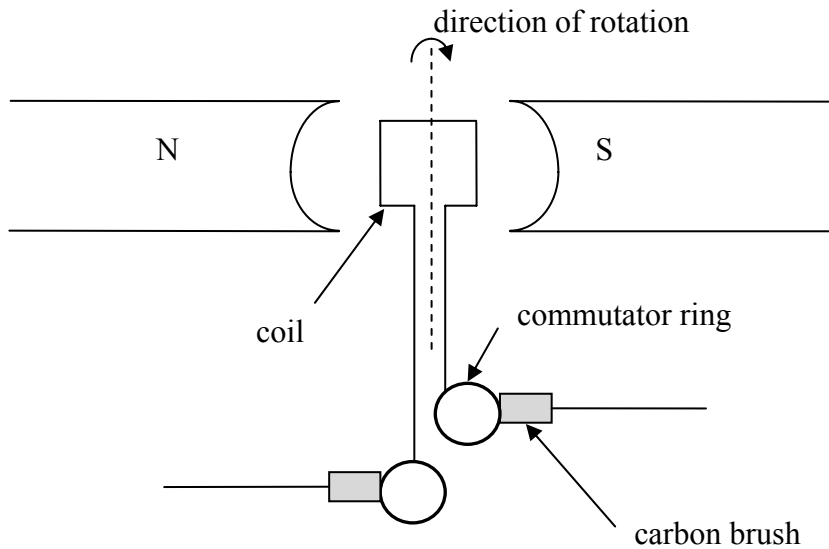

Figure 3

Starting from a certain position at time $t = 0\text{ s}$, the variation of flux with time is shown in Figure 4 for the first 0.04 s .

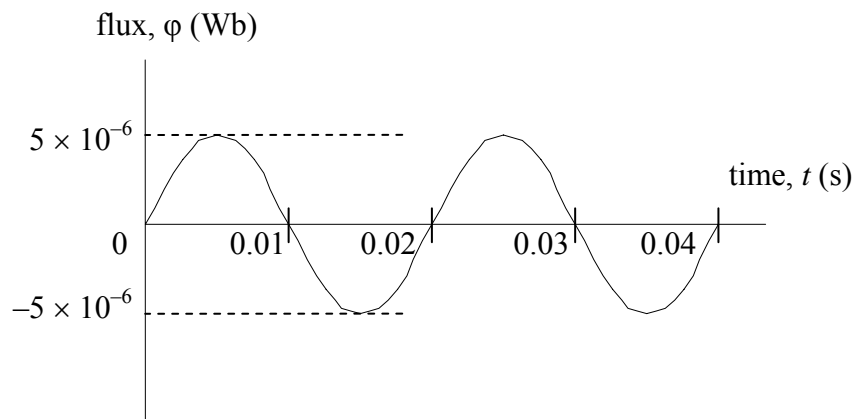

Figure 4

Question 9

What is the magnitude of the maximum magnetic field strength experienced by the coil?

Worked solution

$$B = \frac{\phi_{\max}}{A} = \frac{5 \times 10^{-6}}{0.02^2} = 0.0125$$

$$= 12.5\text{ mT}$$

0.0125 T

2 marks

Mark allocation

- 1 mark for substituting correct values of flux and area.
- 1 mark for correct answer.

Question 10

A CRO measures the voltage output across the commutator as a function of time. On the axes sketched in Figure 5, which shows the original variation of flux with time, sketch the CRO voltage signal for time $t = 0$ to $t = 0.04$ s. Show your working and add a suitable scale on the y-axis.

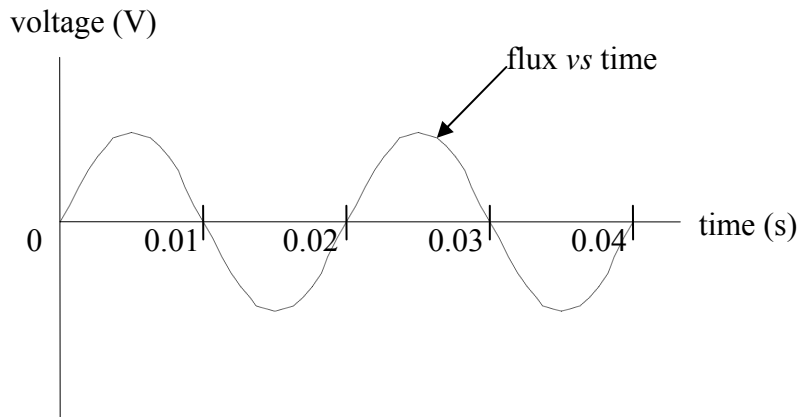
**Figure 5****Worked solution**

$$\text{Maximum induced EMF} = -N \frac{\Delta\phi}{\Delta t} = -10 \times \frac{5 \times 10^{-6}}{0.005} = -0.01 \text{ V}$$

Frequency does not change.

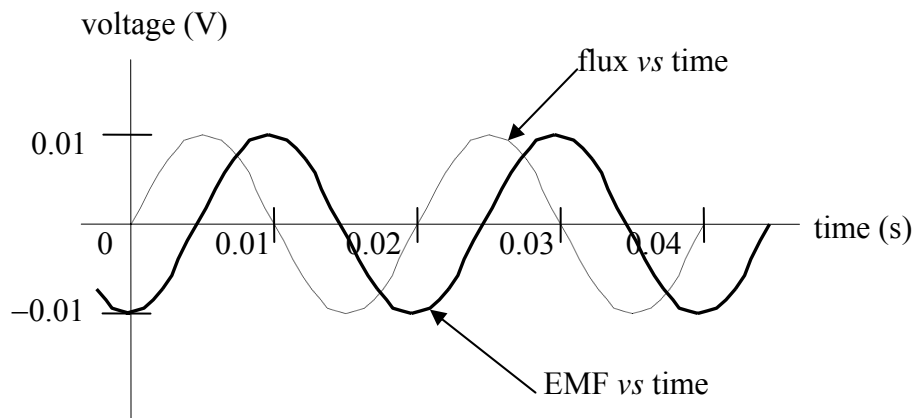

3 marks

Mark allocation

- 1 mark for correct estimation of maximum EMF.
- 1 mark for correct frequency.
- 1 mark for appropriate scale on y-axis.

Tips

- *EMF is the negative gradient of rate of change of flux \times number of turns.*
- *Time period of the flux graph does not change when estimating induced EMF.*

SECTION A – Area of study 1 – continued
TURN OVER

The following information applies to Questions 11 and 12.

A 20-turn flat coil DC motor of sides 3 cm^2 is spinning at a frequency of 50 Hz in a uniform magnetic field of strength 5 mT. The current in the coil is measured to be 3 A.

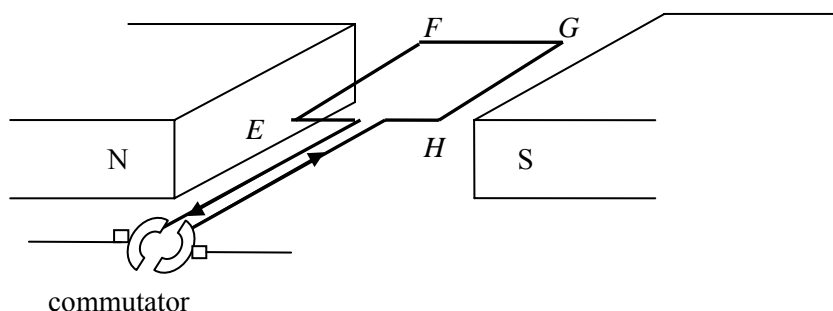

Figure 6

Question 11

Starting from the position shown in Figure 6, what is the magnitude of the magnetic force on side EF at time $t = 0 \text{ s}$?

Worked solution

$$\begin{aligned} F &= nBIl \\ &= 20 \times 5 \times 10^{-3} \times 3 \times 0.03 \\ &= 9 \times 10^{-3} \text{ N} \end{aligned}$$

$9 \times 10^{-3} \text{ N}$

2 marks

Mark allocation

- 1 mark for identifying all quantities correctly in the equation.
- 1 mark for the correct answer.

Question 12

Looking at the coil from the location of the commutator, will the motor spin clockwise or anticlockwise? Explain your answer.

Worked solution

Using the Right Hand rule, the force on the conductor GH will be downwards.

Hence, the coil will rotate clockwise.

clockwise

2 marks

Mark allocation

- 1 mark for correct explanation, such as using Right Hand rule.
- 1 mark for correct conclusion.

Tips

- When using the Right Hand rule, remember the direction of the current flow is that of conventional current, i.e. positive charges.
- Force on a coil is the sum of force on each turn; hence, force on each turn needs to be multiplied by the number of turns.

The following information applies to Questions 13 and 14.

A permanent magnet is set into oscillations by the use of a spring such that the north pole of the magnet enters a solenoid briefly and then oscillates about its mean position. It is assumed that the motion of the magnet is not influenced measurably by air friction.

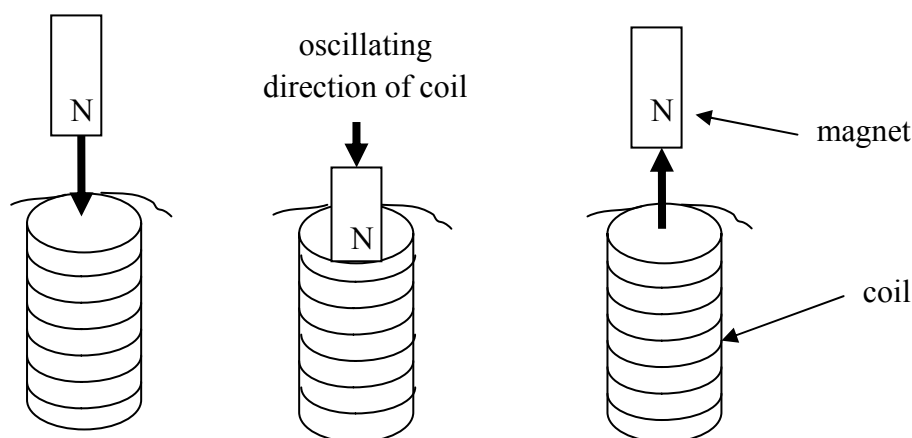

Figure 7

Question 13

What is the direction of induced current as the magnet inserts into the solenoid? Explain your answer.

Worked solution

As the magnet is inserted, north pole is introduced in the coil. Therefore, the current in the coil will be anticlockwise, which is consistent with an induced north pole at the top of the coil.

anticlockwise

2 marks

Mark allocation

- 1 mark for reasoning.
- 1 mark for correct answer.

Question 14

Explain what would be the effect of doubling the frequency of the magnet's oscillation on the induced EMF.

Worked solution

Consistent with Lenz's law, i.e. induced $EMF = -N \frac{\Delta\phi}{\Delta t}$, magnitude will double and time period will halve.

2 marks

Mark allocation

- 1 mark for concluding magnitude will double.
- 1 mark for concluding time period will halve (or frequency will double).

SECTION A – Area of study 1 – continued
TURN OVER

Tip

- *Lenz's law assists with determining the effects of number of turns and rate of change of flux. It also shows that the induced EMF must oppose the flux change that caused it.*

Question 15

An electromagnet is shown in Figure 8. Sketch **three** significant lines of magnetic field created in and around the electromagnet due to the current.

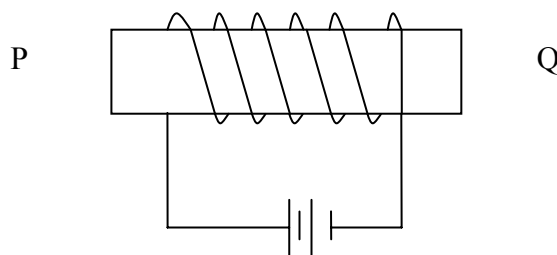
**Figure 8****Worked solution**

Using the Right Hand grip rule, it can be concluded that side P will be a north pole.

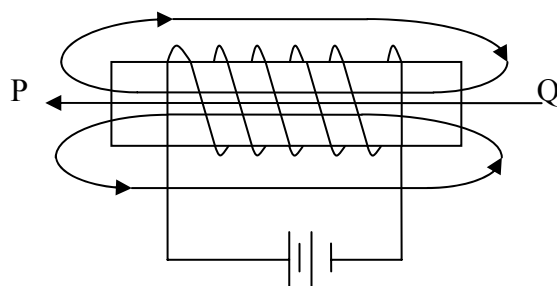

2 marks

Mark allocation

- 1 mark for showing at least one complete loop.
- 1 mark for showing correct direction of arrows on the field lines.

Tips

- *Magnetic field lines are complete loops.*
- *Magnetic field lines have a direction in accordance with the Right Hand grip rule.*

The following information applies to Questions 16–18.

A light bulb is lit up using a 9 V DC battery and a **small** amount of current, as shown in Figure 9.

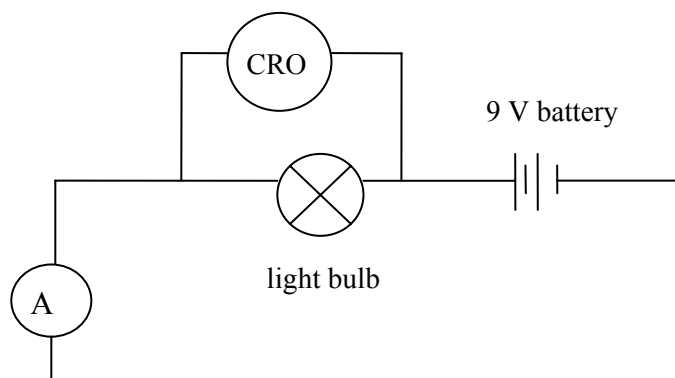

Figure 9

Question 16

Which of the following graphs, A to D, best represents the lamp's voltage versus current graph?

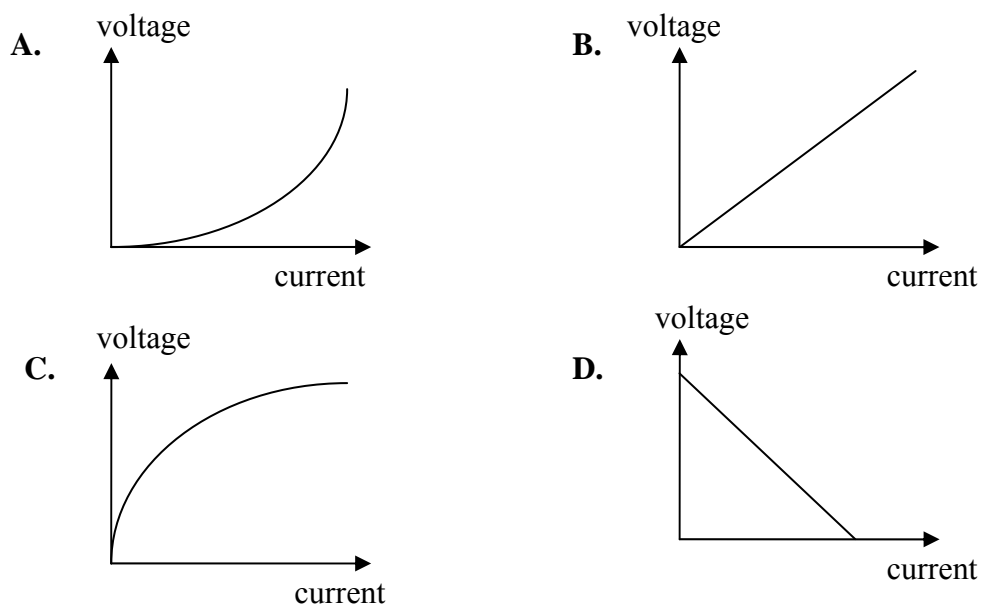

Figure 10

Worked solution

For small currents, the lamp will behave as an Ohmic conductor. Hence, the resistance, which is the gradient of the V - I graph, will be constant.

B

2 marks

Mark allocation

- 2 marks for correct choice. No part marks.

SECTION A – Area of study 1 – continued
TURN OVER

Question 17

Which of the following graphs, A to D, best represents the lamp's power loss versus current?

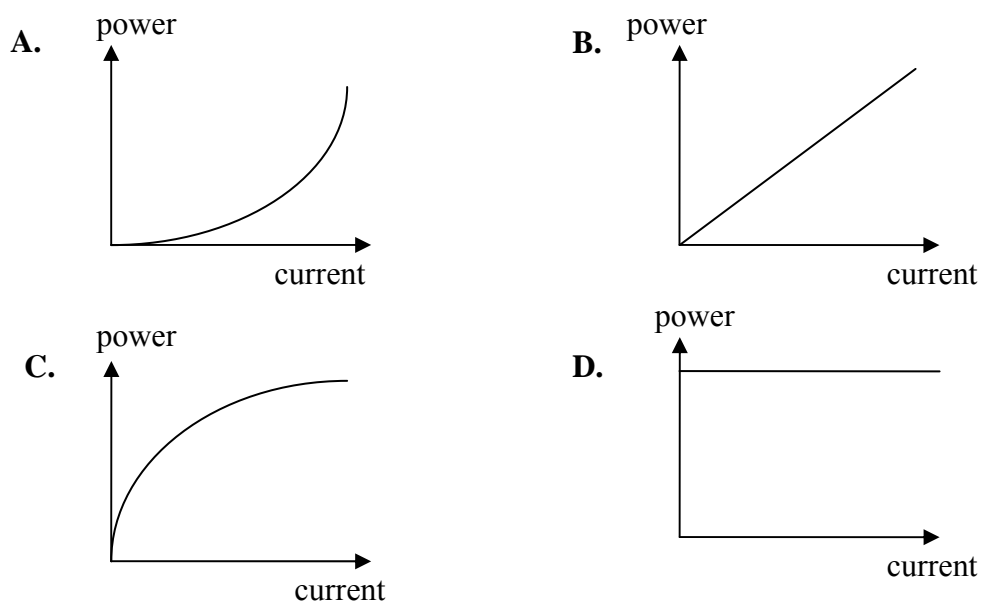
**Figure 11****Worked solution**

Power loss is proportional to the current squared. Hence, the graph of power loss versus current will be a $y = mx^2$ graph, which is option A.

A

2 marks

Mark allocation

- 2 marks for correct answer. No part marks.

Question 18

The 9 V DC battery is now replaced by a variable AC power supply. What AC peak voltage will give the same lighting effect of the light bulb as the 9 V DC battery?

Worked solution

$$V_{\text{peak}} = V_{\text{RMS}} \times \sqrt{2} = 9 \times \sqrt{2} = 12.7 \text{ V}$$

12.7 V

2 marks

Mark allocation

- 1 mark for recognising the correct relationship between AC peak, RMS voltage and DC voltage.
- 1 mark for correct answer.

Tips

- An AC RMS voltage provides the same heating effect as equivalent DC voltage.
- Some non-Ohmic devices may behave as Ohmic over small current and voltage.

END OF AREA OF STUDY 1
SECTION A – continued

Area of study 2 – Interactions of light and matter

Use the following information to answer Questions 1–4.

A certain gas is being researched when in its ground state. Its energy level diagram is shown in Figure 1.

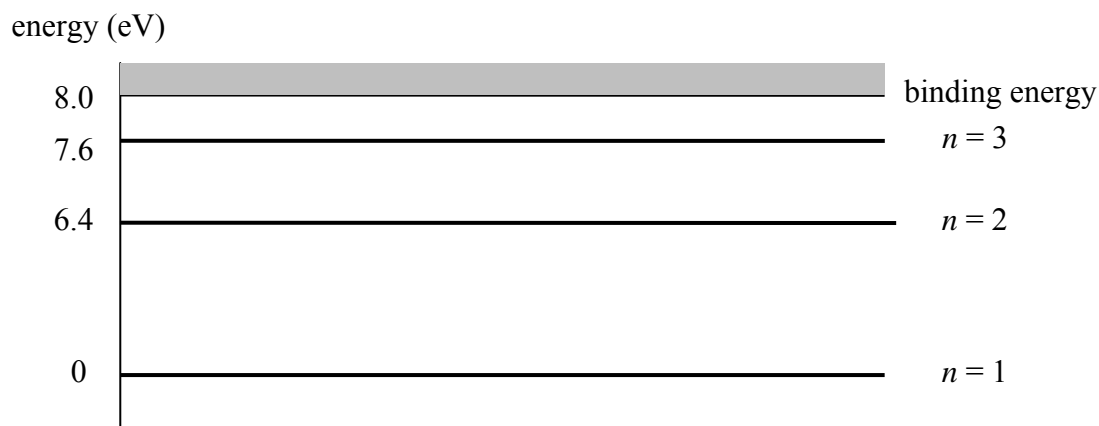

Figure 1

Question 1

What would be the longest wavelength expected in the absorption spectra of the gas in its ground state?

Worked solution

Longest wavelength corresponds to minimum energy = 6.4 eV for transition from a state of $n=1$ to $n=2$.

$$\lambda = \frac{hc}{E} = \frac{4.14 \times 10^{-15} \times 3 \times 10^8}{6.4}$$

$$= 194 \text{ nm}$$

194 nm

2 marks

Mark allocation

- 1 mark for substituting correct values into correct equation.
- 1 mark for correctly giving answer in nanometres.

Question 2

Estimate one wavelength that exists in the emission spectra but not in the absorption spectra for the gas when in its ground state.

Worked solution

The transition of electron from state $n = 3$ to $n = 2$ would exist in the emission spectra but not in the absorption spectra.

$$\lambda = \frac{hc}{E} = \frac{4.14 \times 10^{-15} \times 3 \times 10^8}{1.2}$$

$$= 1035 \text{ nm}$$

1035 nm

2 marks

Mark allocation

- 1 mark for correct identification of transition.
- 1 mark for correct calculation of wavelength.

A sample of this gas, which is enclosed in a glass vessel at room temperature, is subjected to a monochromatic beam as part of a research project. When Steven shines a monochromatic beam of 8.3 eV onto this gas, electrons are released and an absorption line is also seen in the absorption spectra. However, when Casey shines a monochromatic beam of 7.4 eV, no electrons are released and no lines are seen in the absorption spectra.

Question 3

Explain, with reference to energy levels of the gas, why Steven saw an absorption line whereas Casey did not.

Worked solution

Electrons would absorb only those energy photons that have energy equal to discrete jumps to other stationary states or to ionisation. Photons of 8.3 eV will be absorbed to ionise electrons from ground state to ionisation. Photons of energy 7.4 eV will not be absorbed as there is no allowed energy state where an electron in the ground state can be excited to go to with absorption of 7.4 eV.

2 marks

Mark allocation

- 1 mark for explaining why 8.3 eV is absorbed.
- 1 mark for explaining why 7.4 eV is not absorbed.

Question 4

What will be the maximum kinetic energy of the electrons released in Steven's experiments?

Worked solution

$$E_{k,\max} = \text{Energy of incident photon} - \text{Energy absorbed for ionisation}$$

$$E_{k,\max} = 8.3 - 8.0 \text{ eV} = 0.3 \text{ eV}$$

$$= 0.3 \times 1.6 \times 10^{-19} \text{ J}$$

$$= 0.48 \times 10^{-19} \text{ J}$$

$0.48 \times 10^{-19} \text{ J}$

2 marks

Mark allocation

- 1 mark for substituting correct values into the formula.
- 1 mark for correct answer.

Use the following information to answer Question 5.

A beam of electrons is generated in an electron gun and travels through a vacuum chamber under an accelerating voltage of 12 000 V. The beam is intercepted by a mono-atomic crystal, which is acting as a diffraction grating.

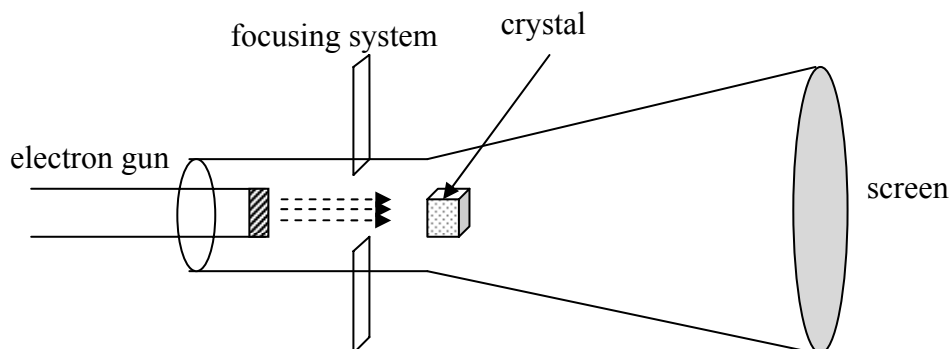
**Figure 2****Question 5**

Calculate the de Broglie wavelength of the electrons at the instant they strike the crystal.

Worked solution

$$E_k = q_e \times V = \frac{1}{2}mv^2$$

$$\therefore \text{Momentum, } p = \sqrt{(2q_eVm)}$$

$$\text{de Broglie wavelength, } \lambda = \frac{h}{\sqrt{2q_eVm_e}}$$

$$= \frac{6.63 \times 10^{-34}}{\sqrt{(2 \times 1.6 \times 10^{-19} \times 12\,000 \times 9.1 \times 10^{-31})}}$$

$$= 1.2 \times 10^{-11} \text{ m}$$

$$= 121 \text{ nm}$$

Alternatively, find speed ($= 0.5 \times 10^7 \text{ ms}^{-1}$), then momentum ($= 5.9 \times 10^{-23} \text{ kg ms}^{-1}$), followed by wavelength.

121 nm

3 marks

SECTION A – Area of study 2 – continued
TURN OVER

Mark allocation

- 1 mark for correct derivation or identification of formulas.
- 1 mark for substituting correct values into the formulas.
- 1 mark for correct answer.

Tips

- *Make a table of relationships between wavelength, momentum, kinetic energy, speed and voltage for a particle and a photon.*
- *Use units of joules for energy and Planck's constant when in doubt.*

Use the following information to answer Questions 6 and 7.

A laser light beam, which is monochromatic and coherent, and of wavelength 450 nm, is shone through a pair of narrow slits, 0.15 mm apart, as part of an investigation of Young's experiment, as shown in Figure 3. A pattern of high-intensity lines separated by regions of darkness are observed on the screen, which is placed 2.5 m away from the slits.

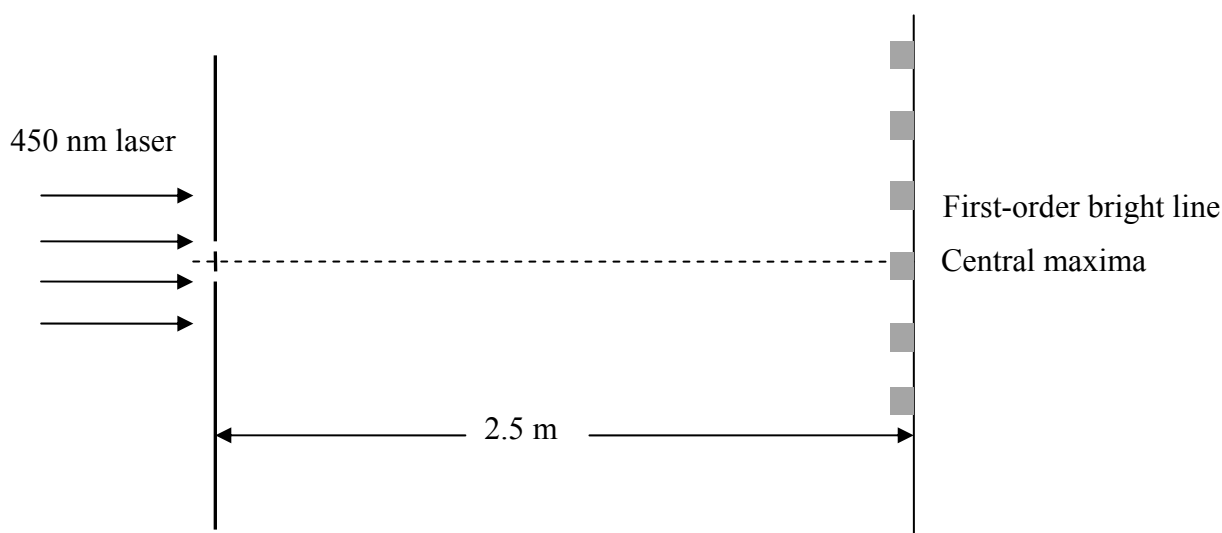

Figure 3

Question 6

What will be the distance of the first-order bright intensity line from the centre of the central maxima?

Worked solution

Using the $\sin \theta \approx \tan \theta$ approximation for Young's double slit experiment:

$$\frac{x}{L} = \frac{n\lambda}{d}$$

Hence,

$$\begin{aligned} x &= \frac{L\lambda}{d} \\ &= \frac{2.5 \times 450 \times 10^{-9}}{0.15 \times 10^{-3}} \\ &= 0.0075 \text{ m} \\ &= 7.5 \text{ mm} \end{aligned}$$

7.5 mm

2 marks

Mark allocation

- 1 mark for identifying correct relationship between the physical quantities and identifying $n = 1$.
- 1 mark for correct answer.

Question 7

If one of the slits is covered up, estimate the **maximum** width of the single slit that is needed in order to see significant diffraction. Explain the reasoning for your answer.

Worked solution

Extent of diffraction $\alpha \frac{\lambda}{w}$, $\lambda > w$, where w is the width of the opening. Therefore, for significant diffraction to occur, the width of the slip must be less than the wavelength $w < 450 \text{ nm}$.

450 nm

2 marks

Mark allocation

- 1 mark for correct reasoning based on wavelength and slip opening.
- 1 mark for correct conclusion.

Tip

- *The mathematical expression for Young's experiment, i.e. $\frac{x}{L} = \frac{p.d.}{d}$, where p.d. is the path difference, helps to answer a number of questions about the physical relationships between the variables.*

Use the following information to answer Questions 8–11.

The photoelectric properties of a metal were studied by using a photoelectric cell where the metal is used as a photocell and the light source has monochromatic but variable frequency. Such a light source could be a tuneable laser. The data were plotted in two different ways and are shown in Figures 4a and 4b. In Figure 4a, the magnitude of photocurrent is plotted against stopping voltage, V_s , for a certain frequency ' f_1 '. In Figure 4b, the maximum kinetic energy of the emitted photo-electron is graphed against a range of frequencies.

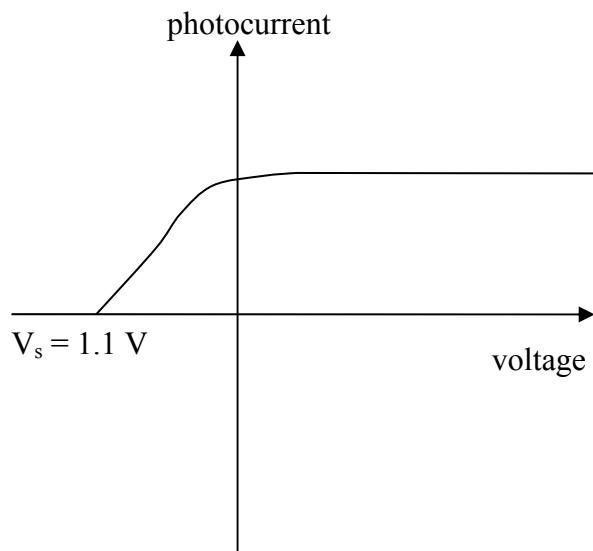

Figure 4a

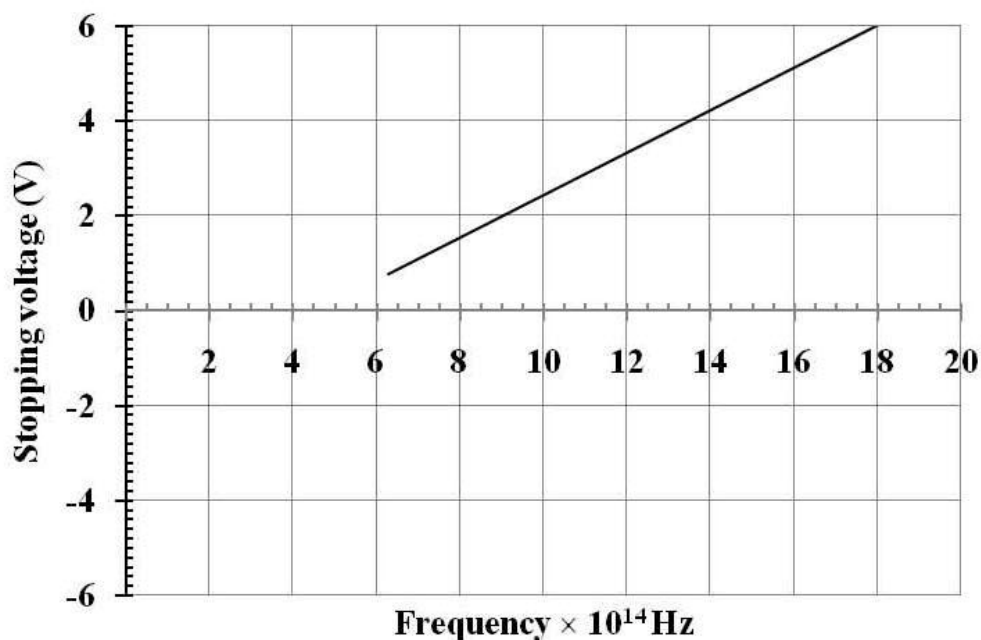

Figure 4b

Question 8

Use the graphical data from Figures 4a and 4b to determine the frequency of light, ' f_1 ', used in this experiment.

Worked solution

Frequency used = Cut-off voltage $\div h$

$$f_1 = \frac{1.1}{4.14 \times 10^{-15}} = 2.66 \times 10^{14} \text{ Hz}$$

$2.66 \times 10^{14} \text{ Hz}$

2 marks

Mark allocation

- 1 mark for relating cut-off potential to frequency.
- 1 mark for correct answer.

Question 9

Which of the graphs, A to D, best represents the outcome when the frequency of the incident light beam is increased **and** the intensity of the incident light beam is decreased? The original light beam (dashed line) is shown for reference. Explain your choice of answer.

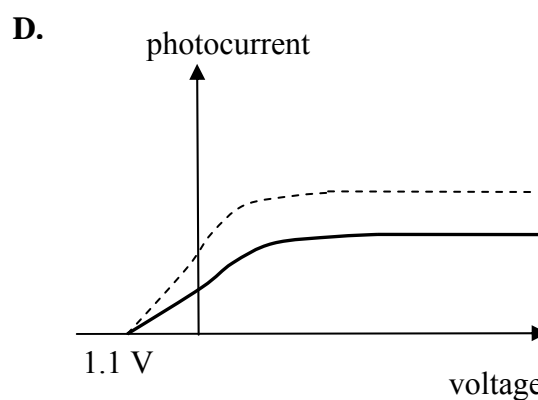
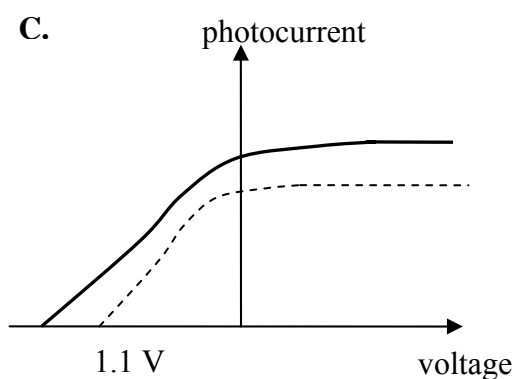
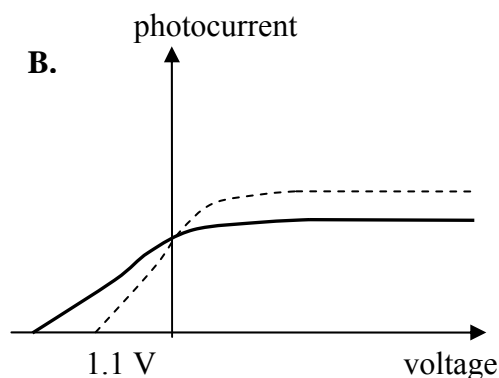
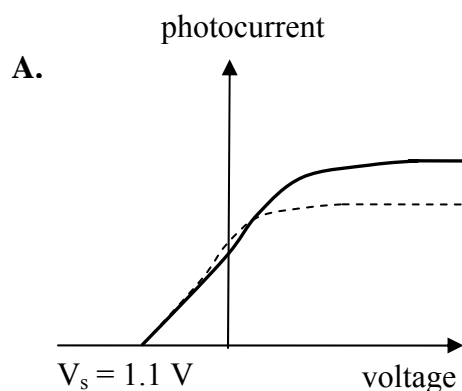

Worked solution

Increasing the frequency can result in a lower cut-off potential.

Decreasing the intensity results in fewer photons and, hence, fewer photoelectrons.

Therefore, the correct answer is B.

B

2 marks

Mark allocation

- 1 mark for describing the correct link between frequency, intensity and photocurrent.
- 1 mark for correct choice.

Question 10

From the graphical data of Figures 4a and 4b, determine the work function of the metal. Show your working.

Worked solution

Work function is y-axis intercept, i.e. 2 eV.

Alternatively, find the gradient (see *Worked solution* of next question), and use this value to calculate the work function using $W = hf_0$.

2 eV

2 marks

Mark allocation

- 1 mark for establishing the work function as either the y-axis intercept or the gradient \times x-axis intercept.
- 1 mark for correct answer. A range of reasonable values is permitted if working is shown. Subtract 1 mark if working is not shown.

Question 11

Using the graphical data from Figures 4a and 4b, what is the value of Planck's constant? You must show your working.

Worked solution

Planck's constant = Gradient of the graph

$$\begin{aligned}
 h &= \frac{\text{rise}}{\text{run}} = \frac{2 \times 10^{-14}}{4.9} \\
 &= 4.1 \times 10^{-15} \text{ eVs} = 4.1 \times 10^{-15} \times 1.6 \times 10^{-19} \text{ Js (where } 1 \text{ eV} = 1.6 \times 10^{-19} \text{ J)} \\
 &= 6.5 \times 10^{-34} \text{ Js}
 \end{aligned}$$

$6.5 \times 10^{-34} \text{ Js}$

3 marks

Mark allocation

- 1 mark for stating that the gradient is Planck's constant.
- 1 mark for correct calculation of gradient.
- 1 mark for converting eVs to Js.

Tips

- *Be mindful of the relationship between V, eV and J.*
- *When asked, you must show your working clearly.*
- *When asked to calculate h or W, use values from graph and extend the trendline, using a dashed line for negative values of energy or stopping voltage.*

**END OF SECTION A
TURN OVER**

SECTION B – Detailed studies

Detailed study 1 – Synchrotron and its applications

An electron gun is used to produce electrons of different velocities by appropriately tuning the accelerating electron. A construction of a typical electron gun is shown in Figure 1.

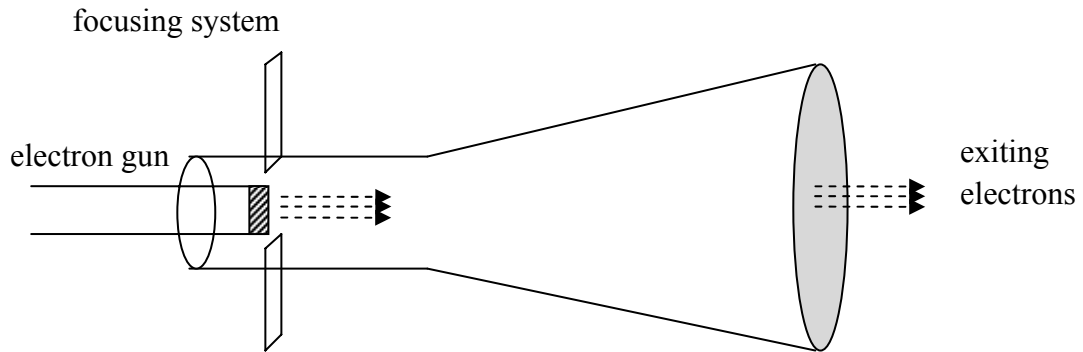

Figure 1

Question 1

What is the voltage necessary to generate electrons of kinetic energy 1 GeV?

- A. 1 gigavolt
- B. 1.6 gigavolt
- C. 1.6×10^{-19} V
- D. 1.6×10^{-13} V

A

Worked solution

1 gigavolt voltage is needed to give an electron 1 GeV of energy.

2 marks

Question 2

What is the speed of electrons upon exiting from the gun when the accelerating voltage is 2500 V?

- A. About $2 \times 10^7 \text{ ms}^{-1}$.
- B. About $2.5 \times 10^6 \text{ ms}^{-1}$.
- C. About $3 \times 10^8 \text{ ms}^{-1}$.
- D. About $3 \times 10^7 \text{ ms}^{-1}$.

D

Worked solution

Using $q_e V = \frac{1}{2} m v^2$,

$$v = \sqrt{\frac{2q_e V}{m_e}}$$

$$= \sqrt{\frac{2 \times 1.6 \times 10^{-19} \times 2500}{9.1 \times 10^{-31}}}$$

$$= 2.965 \times 10^7 \text{ ms}^{-1}$$

Hence, correct answer is D.

2 marks

Question 3

An electron with velocity $3 \times 10^6 \text{ ms}^{-1}$ enters a uniform magnetic field of $5 \times 10^{-3} \text{ T}$, as shown in Figure 2. The force on the electron is best described as

- A. $1.5 \times 10^4 \text{ N}$ to the right.
- B. $2.4 \times 10^{-15} \text{ N}$ to the left.
- C. $2.4 \times 10^{-15} \text{ N}$ to the right.
- D. $1.5 \times 10^4 \text{ N}$ to the left.

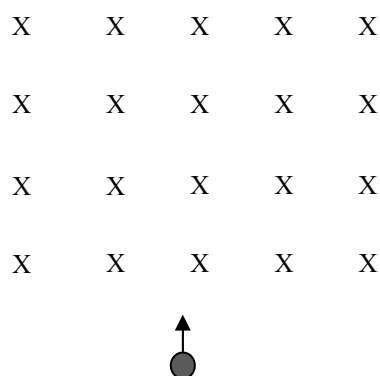
**Figure 2**

C

SECTION B – Detailed study 1 – continued
TURN OVER

Worked solution

$$\begin{aligned}
 F &= Bqv \\
 &= 5 \times 10^{-3} \times 1.6 \times 10^{-19} \times 3 \times 10^6 \\
 &= 2.4 \times 10^{-15} \text{ N}
 \end{aligned}$$

Using the Right Hand rule, the force on a positive charge will be to the left. Hence, force on the electron will be to the right. Hence, correct answer is C.

2 marks

Tip

- *The Right Hand rule is used to find force on a positive charge. If negative charge is under consideration, the direction determined by the Right Hand rule must be reversed.*

Use the following information to answer Questions 4–7.

The following statements, A to D, refer to the functioning and design of one component of the Australian synchrotron.

- A.** Electrons are kept in a circular path for hours at a time and close to the speed of light. Synchrotron light is emitted when electrons change direction. Loss of energy due to synchrotron radiation is replenished by RF chambers.
- B.** Electrons are bent into a circular path by magnets positioned at right angles to the electron beam. Energy of the electrons is increased as they travel through built-in RF chambers.
- C.** It produces electrons and accelerates them across a potential difference in a high vacuum chamber, using focusing systems to narrow the beam.
- D.** Situated within the storage ring and consisting of alternating magnetic poles, this component increases the brightness of the synchrotron light.

For Questions 4–7, identify the component of the Australian synchrotron with its function described in statements A, B, C or D.

Question 4

The 'linac':

C

2 marks

Question 5

The circular booster:

B

2 marks

Question 6

The storage ring:

A

2 marks

Question 7

Wigglers:

D

2 marks

Tip

- *For a better understanding of the Australian synchrotron, make a table of all components, their location and their purpose.*

Use the following information to answer Questions 8 and 9.

Crystal diffraction analysis is carried out on a sample of a newly developed crystalline material using a 1.5 keV X-ray beam. In the first experiment, the X-ray beam, with energy 1.5 keV, is produced by a normal laboratory X-ray tube. In the second experiment on the same crystalline material, the X-ray beam is produced by a synchrotron.

Question 8

In the context of X-ray diffraction, which of the following statements best describes the advantage of X-rays produced by the synchrotron over those produced by a normal laboratory X-ray tube?

- A. The beam produced by the synchrotron is coherent, which results in a better resolution.
- B. The beam produced by the synchrotron has a much narrower range of wavelengths, which results in a better resolution.
- C. The beam produced by the synchrotron has a higher intensity and a low divergence, which contributes to a better resolution.
- D. The beam produced by the synchrotron has very high energy.

C

2 marks

Tip

- *List the advantages of synchrotron technology, which include range of wavelengths produced, low divergence, high intensity, and diversity of analytical techniques possible in one location.*

Question 9

A crystal of the new material shows a diffraction image with the 1.5 keV X-ray beam. A graph of X-ray diffracted intensity versus angle shows a sharp line at 28° , as shown in Figure 3.

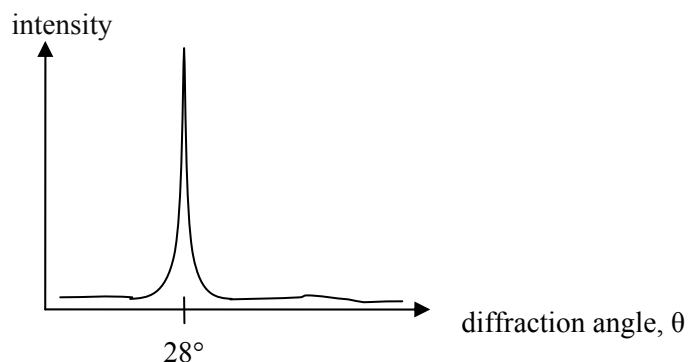
**Figure 3**

The inter-atomic distance is most likely to be

- A. 3.1×10^{-10} m
- B. 2.4×10^{-9} m
- C. 8.8×10^{-10} m
- D. 8.3×10^{-10} m

C

Worked solution

$$\begin{aligned} \text{The wavelength of 1.5 keV X-rays} &= \frac{hc}{E} = \frac{4.14 \times 10^{-15} \times 3 \times 10^8}{1.5 \times 10^3} \\ &= 8.28 \times 10^{-10} \text{ m} \end{aligned}$$

Using Bragg's law, $2d \sin \theta = n\lambda$

$$\begin{aligned} d &= \frac{n\lambda}{2 \sin \theta} \\ &= \frac{8.28 \times 10^{-10}}{2 \sin 28^\circ} \\ &= 8.82 \times 10^{-10} \text{ m} \end{aligned}$$

The closest answer is C.

2 marks

Question 10

As electrons bend in a circular path in a synchrotron, the photon beam is produced

- A. tangent to the path of the electron beam.
- B. perpendicular to the path of the electron beam and directed towards the centre of the circular path.
- C. along the path of the electron beam.
- D. perpendicular to the path of the electron beam and directed away from the centre of the circular path.

A

2 marks

Tip

- *Synchrotron radiation is produced in a tangent line to the circular path of the electron. The analytical instruments are arranged along this line, which is called the 'beam line'.*

Question 11

The radiation produced in the Australian synchrotron is called 'synchronous'. Which one of the following is the best explanation of this definition?

- A. All radiation produced has the same energy and, hence, is of a single wavelength. This allows for exceptionally detailed analysis of materials.
- B. Electrons that release radiation are of nearly equal energy as they travel in circular paths in the storage ring. The radiation they release upon bending consists of a range of wavelengths.
- C. The radiation produced is very intense and monochromatic.
- D. All radiation produced is in phase.

B

2 marks

Tip

- *Synchrotron radiation is not of a single wavelength. It is intense and spreads little spatially, similar to a laser in this respect.*

Use the following information to answer Questions 12 and 13.

A photon of wavelength 0.08 nm scatters from a graphite sample within an X-ray tube, as shown in Figure 4. A scattered photon of wavelength 0.09 nm and an electron are detected, consistent with the Compton effect.

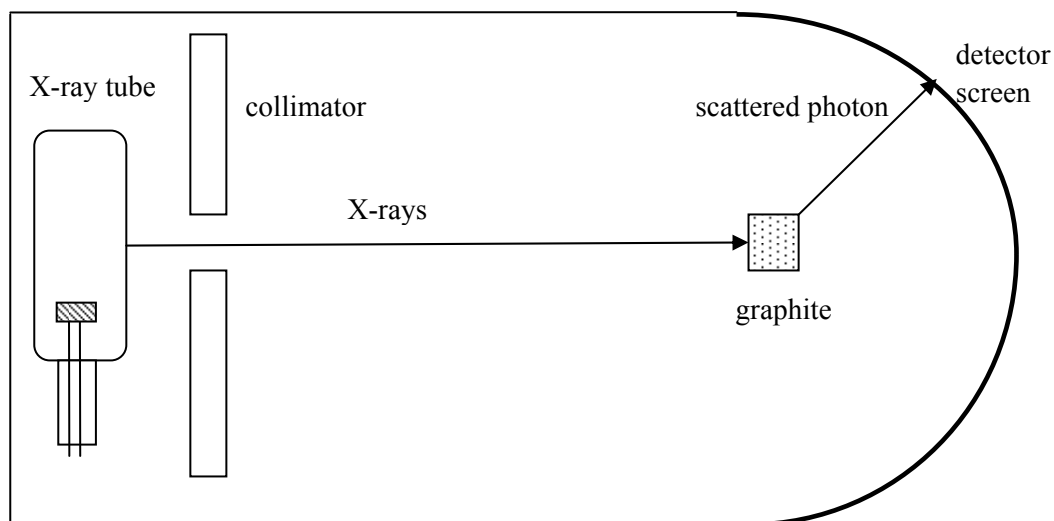

Figure 4

Question 12

What is the kinetic energy of the electron? Show your working.

- A. 1530 eV
- B. 100 eV
- C. 1600 eV
- D. 1725 eV

D

Worked solution

Applying conservation of energy,

Kinetic energy of the electron = Energy of incident photon – Energy of scattered photon

$$\begin{aligned}
 &= \frac{hc}{0.08 \times 10^{-9}} - \frac{hc}{0.09 \times 10^{-9}} \\
 &= 1725 \text{ eV}
 \end{aligned}$$

Hence, correct answer is D.

2 marks

Tip

- Use appropriate value of Planck's constant in energy-related questions.

Question 13

Which one of the following statements best contrasts Compton and Thomson scattering?

- A.** Compton scattering is an *elastic* collision between an incident photon and an electron and there is no wavelength shift in the photon. Thomson scattering is an *inelastic* collision and there is a wavelength shift in the scattered photon.
- B.** Thomson scattering is an *elastic* collision between an incident photon and an electron and there is no wavelength shift in the photon. Compton scattering is an *inelastic* collision and there is a wavelength shift in the scattered photon.
- C.** Thomson scattering is an *inelastic* collision between an incident photon and an electron and there is a wavelength shift in the photon. Compton scattering is an *elastic* collision and there is no wavelength shift in the scattered photon.
- D.** Thomson scattering is an *inelastic* collision between an incident photon and an electron and there is no wavelength shift in the photon. Compton scattering is an *elastic* collision and there is a wavelength shift in the scattered photon.

B

2 marks

Tips

- *Compton shift is an inelastic collision and the loss of energy causes the wavelength shift.*
- *Thomson scattering is elastic; hence, there is no energy loss.*

END OF DETAILED STUDY 1
SECTION B – continued
TURN OVER

Detailed study 2 – Photonics

Use the following information to answer Questions 1 and 2.

A piece of iron at room temperature is heated until it glows white hot. The emitted colour taken at various temperatures, P, Q, R and S, is shown in Figure 1.

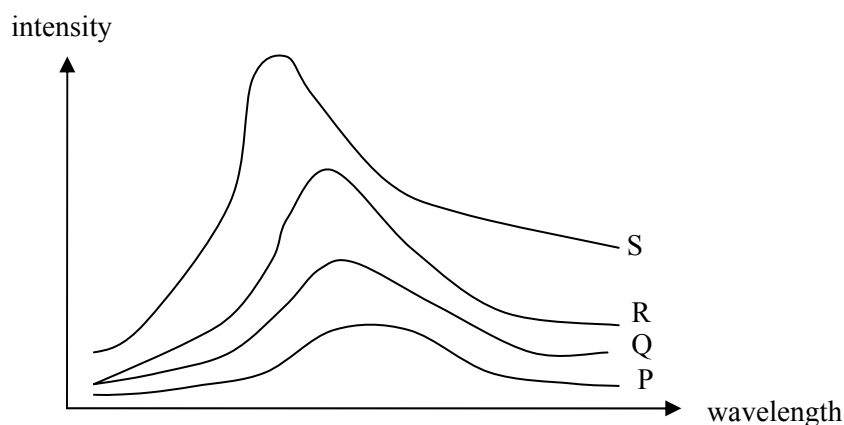

Figure 1

Question 1

The magnitude of temperature decreases in the sequence

- A. $S > Q > R > P$
- B. $S > R > Q > P$
- C. $P > Q > R > S$
- D. $P > R > Q > S$

B

2 marks

Tip

- *As temperature increases, the peak of the wide spectrum moves to a higher energy, i.e. lower wavelength.*

Question 2

Which of the following statements best describes the principal cause of the spectrum?

- A. Thermal motion of electrons.
- B. A wide variety of sources, including accelerating electrons and protons.
- C. Energy transformations in the nucleus.
- D. Chemical changes in the material.

A

2 marks

Tip

- *Although thermal motion of electrons is the principal cause of a wide spectrum, all accelerating charges will emit electromagnetic radiation. If the energy levels are very close together or overlapping, 'band spectrum' or wide spectrum can result.*

Use the following information to answer Questions 3 and 4.

A newly developed semiconductor LED has a band gap of 1.7 eV. To research its light-emitting properties the LED is connected in a circuit, as shown in Figure 2.

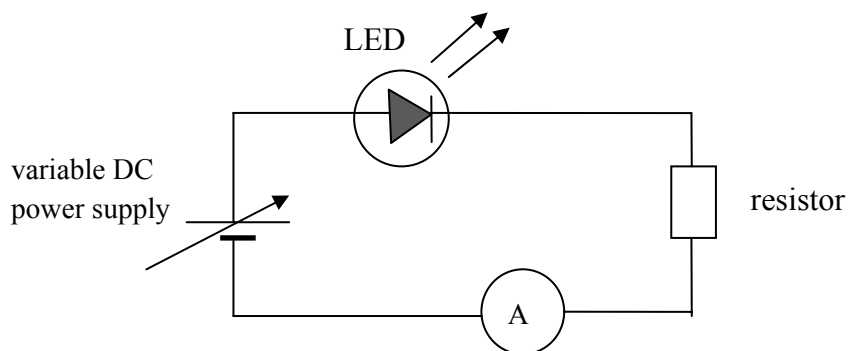
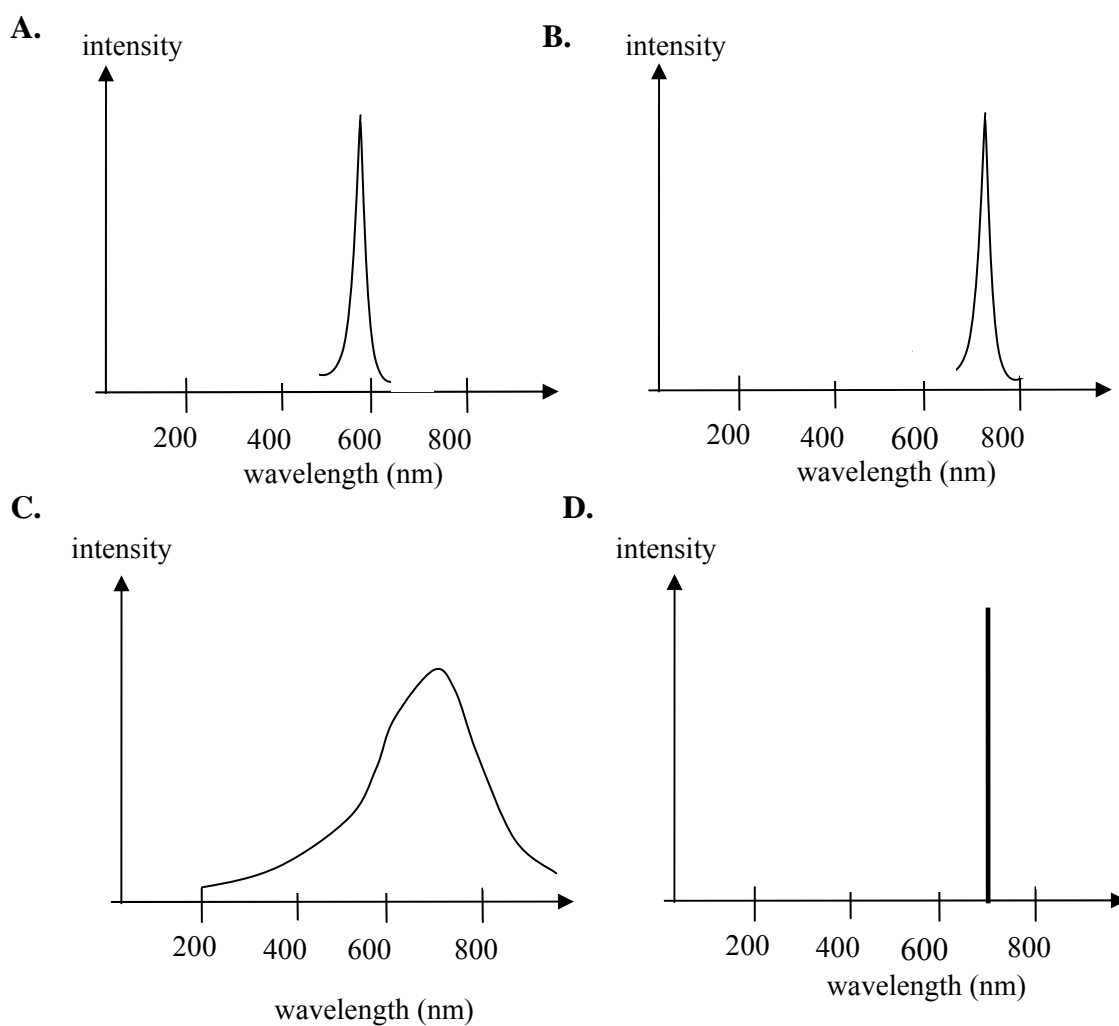

Figure 2

Question 3

Which of the following is the most likely shape of the spectrum emitted by the LED?



SECTION B – Detailed study 2 – continued
TURN OVER

Worked solution

A band gap of 1.7 eV means that radiation emitted by the LED will have maximum intensity at 1.7 eV, but there will be some width to the intensity versus wavelength graph, as opposed to a laser.

$$E = \frac{hc}{\lambda}$$

$$\therefore \lambda = \frac{hc}{E} = \frac{4.14 \times 10^{-15} \times 3 \times 10^8}{1.7}$$

$$= 7.3 \times 10^{-7}$$

$$= 730 \text{ nm}$$

B

2 marks

Question 4

The experiment is repeated with another sample of the LED material but is now found to be emitting a **lower** intensity, although the average wavelength does not change. Which of the following is the most likely cause?

- A. The battery is providing a higher voltage than previously.
- B. The battery is providing a lower voltage than previously.
- C. Some impurities are present in the LED.
- D. The LED is connected in reverse bias.

B

2 marks

Tip

- *The LED spectrum has a range of wavelengths, with the band gap contributing to the maximum intensity. Lasers have a much narrower range of wavelengths.*

Use the following information to answer Questions 5–7.

A ray of light enters a step-index optical fibre from air and undergoes total internal reflection at the core-cladding interface, as shown in Figure 3. The refractive index of air, core and cladding are, respectively, 1.00, 1.52 and 1.49.

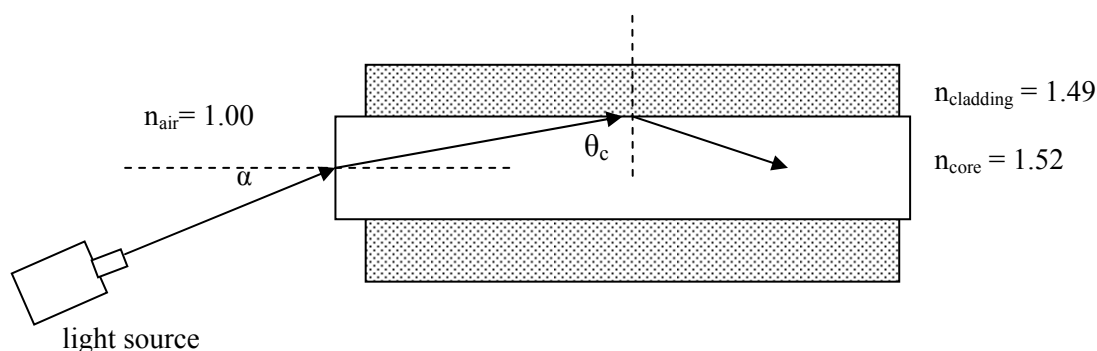

Figure 3

Question 5

The best estimate for critical angle, θ_c , is

- A. 12.4°
- B. 24.8°
- C. 78.6°
- D. 65.2°

C

Worked solution

Using $n_1 \sin \theta_1 = n_2 \sin \theta_2$

$$1.52 \sin \theta_c = 1.49$$

$$\therefore \theta_c = 78.6^\circ.$$

Correct answer is C.

2 marks

Question 6

The numerical aperture of the fibre is

- A. 0.15
- B. 0.20
- C. 0.25
- D. 0.30

D

Worked solution

$$NA = \sqrt{(n_1^2 - n_2^2)} = \sqrt{1.52^2 - 1.49^2} = 0.3$$

2 marks

SECTION B – Detailed study 2 – continued
TURN OVER

Question 7

The acceptance angle, α , is closest in value to

- A. 17.5°
- B. 16.5°
- C. 15.5°
- D. 14.5°

A

Worked solution

Acceptance angle, $\alpha = \sin^{-1}(NA) = 17.46^\circ$

2 marks

Tip

- The sine of an angle is always less than or equal to 1.00, $\sin 90^\circ = 1$.

Use the following information to answer Questions 8–11.

The transmission characteristic graph for a single-mode optical fibre is shown in Figure 4.

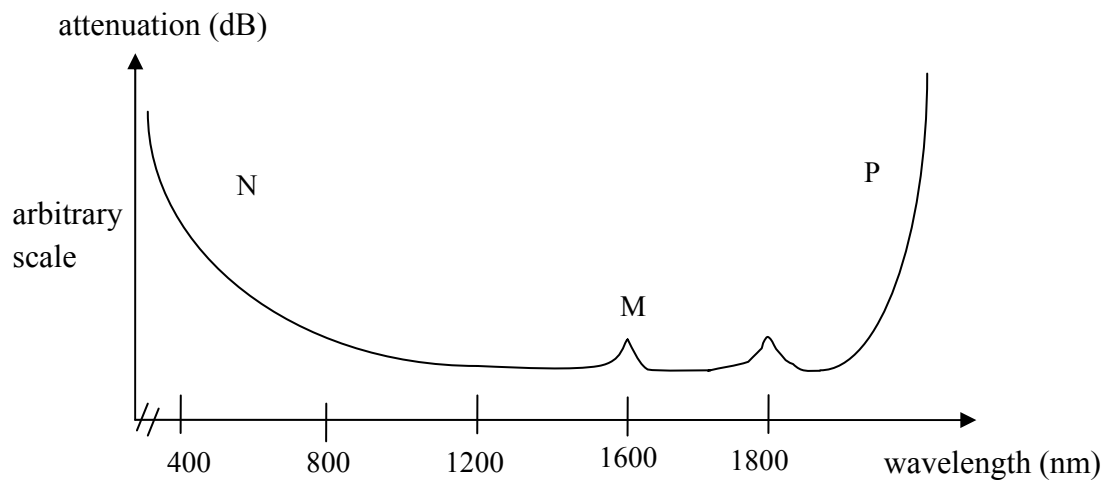

Figure 4

Question 8

An input signal of 1.1 mW was transmitted over 50 km, and 0.8 mW was received at the other end. The attenuation per km of the signal is closest in magnitude to

- A. 15 dB km⁻¹
- B. 1.4 dB km⁻¹
- C. 3 dB km⁻¹
- D. 0.03 dB km⁻¹

D

Worked solution

$$\text{Attenuation} = -10 \log \frac{P_{\text{output}}}{P_{\text{input}}} = -10 \log \frac{0.8}{1.1} = 1.38$$

$$\text{Attenuation per km} = \frac{1.38}{50} = 0.027 \text{ dB km}^{-1}$$

Correct answer is D.

2 marks

Tips

- Attenuation is measured in dB, the ratio of power output to input has no ratio.
- Distinguish between 'attenuation' and 'attenuation per km'.

Question 9

Which of the following statements best identifies the regions corresponding to the loss mechanism?

- A. N is due to Rayleigh scattering, M due to impurities and P due to absorption by the glass structure.
- B. N is due to impurities, M due to Rayleigh scattering and P due to absorption by the glass structure.
- C. N is due to absorption by the glass structure, M due to Rayleigh scattering and P due to absorption by impurities.
- D. N is due to absorption by the glass structure, M due to absorption by impurities and P due to Rayleigh scattering.

A

2 marks

Question 10

John and Sarah argue about the shape of the graph and the reasons for the peaks. Which of the following statements is the best description of the mechanisms of attenuation in the fibre?

- A. Rayleigh scattering occurs due to the glass structure, which is made of atoms such as Si and O and absorbs light radiation.
- B. Absorption at high wavelengths occurs due to structural irregularities absorbing light energy.
- C. Rayleigh scattering occurs when the wavelength of the transmitted signal is less than the size of the structural irregularities, and absorption occurs due to the interaction of the signal with atoms and bonds.
- D. Impurities in the glass structure absorb both specific and a broad range of wavelengths and this is the predominant reason for attenuation in glass fibres.

C

2 marks

Tips

- *Rayleigh scattering is caused by compositional and structural variations and occurs over a range of low wavelengths.*
- *Absorption due to impurities is over a narrower range of wavelengths that is specific to the impurity.*
- *An absorption edge at high wavelengths is caused by light absorption by the silicate structure of the glass.*

Question 11

Not happy with the single-mode optical fibre they were testing, John and Sarah argue about the other options they could use for transmitting a signal over a long distance. Which of the following statements **best** describes **dispersion** in optical fibres?

- A. Modal dispersion is caused by the different wavelengths in the signal travelling in different paths and can be reduced by using a single mode fibre or a thinner core.
- B. Material dispersion is caused by different wavelengths in the signal travelling at different speeds and can be reduced by monochromatic laser light. Blue travels slower than red causing a spread of signal.
- C. Modal dispersion can be significantly reduced by using graded index optical fibre rather than a bunch of several fibres. .
- D. Multimode fibres will allow more data to be transmitted and has lower modal and material dispersion than single mode fibre. However, multimode fibres are more expensive hence not preferred over long distances.

B

2 marks

Tips

- *Material dispersion occurs due to different wavelengths travelling at different speeds and, hence, can be reduced by using a laser light source.*
- *Modal dispersion occurs as light travels at different speeds in different modes. It does not occur in single-mode fibres and is less in graded index and thinner fibres.*

Use the following information to answer Questions 12 and 13.

To image a specimen, an optical imaging bundle is made of two different types of fibre in a composite construction, as shown in Figure 5. The outer fibres, O, carry light to the specimen a short distance of 10–20 cm from the observer, and the inner fibres, I, bring the reflected light back for recording of the image.

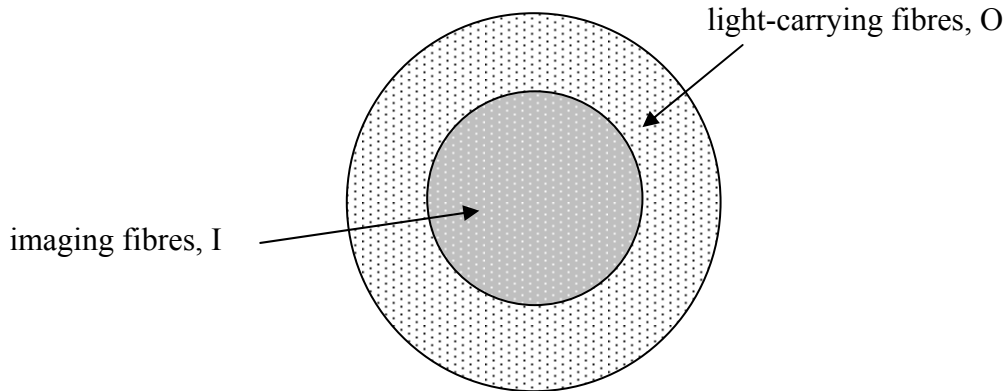

Figure 5

Question 12

The preferred choice for the inner fibre would be

- A. step-index single mode
- B. graded index single mode
- C. step-index multi-mode
- D. graded index multi-mode

A

2 marks

Tip

- *Over a short distance and for a relatively small amount of data per second, a step-index single-mode fibre would have minimum dispersion over other types of fibre.*

Question 13

The resolution of the imaging fibre is 1.5 megapixel. Which array of pixel will give a resolution closest in value to a resolution of 1.5 megapixel? (1 megapixel = 10^6 pixels).

- A. 3870×3870
- B. 1225×1225
- C. $10^3 \times 10^3$
- D. 1450×1225

B

Worked solution

$1225 \times 1225 \approx 1.5 \times 10^6$
Correct answer is B.

2 marks

Detailed study 3 – Sound

Use the following information to answer Questions 1–3.

As shown in Figure 1, a siren sounds a frequency of 800 Hz from the top of a lighthouse sending sound waves in all directions. Joseph and Lim, positioned 80 m and 140 m away respectively, measure the intensity of the sound wave. At a certain time Joseph measures the intensity to be $3 \times 10^{-5} \text{ Wm}^{-2}$.

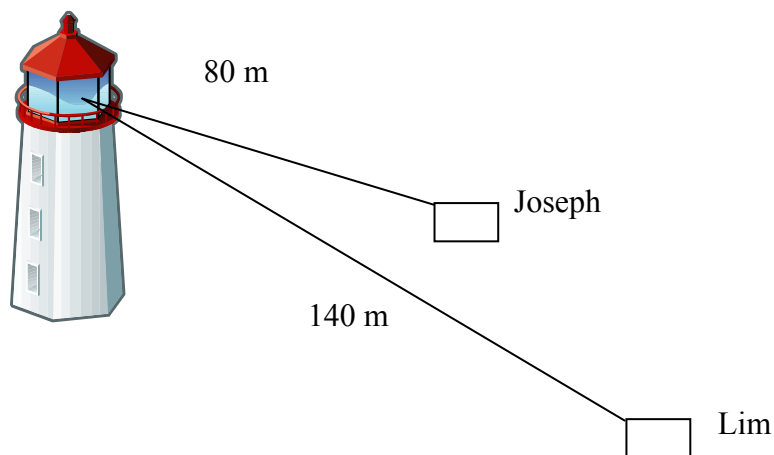

Figure 1

Question 1

Which of the following is the best estimate of the power of the siren?

- A. 3 W
- B. 2.4 W
- C. 0.37 W
- D. 24 W

B

Worked solution

$$\begin{aligned}
 P &= I \times A \\
 &= 3 \times 10^{-5} \times 4 \times \pi \times (80)^2 \\
 &= 2.4 \text{ W}
 \end{aligned}$$

2 marks

Question 2

What is the sound intensity level (dB) measured by Lim at 140 m?

- A. 70 dB
 B. 60 dB
 C. 80 dB
 D. 50 dB

A

Worked solution

Using the inverse square law:

$$I_{\text{Joseph}} \times R_{\text{Joseph}}^2 = I_{\text{Lim}} \times R_{\text{Lim}}^2$$

$$3 \times 10^{-5} \times (80)^2 = I_{\text{Lim}} \times (140)^2$$

$$\therefore I_{\text{Lim}} = 0.98 \times 10^{-5} \text{ W}$$

$$\text{dB} = 10 \log (0.98 \times 10^{-5}) + 120$$

$$= 69.9 \text{ dB}$$

Hence, correct answer is A.

2 marks

Question 3

Which of the following is the best answer for the **difference** in dB recorded by Joseph and Lim?

- A. About 6 dB.
 B. About 5 dB.
 C. About 4 dB.
 D. About 3 dB.

B

Worked solution

Sound intensity level measured by Joseph = $10 \log (3 \times 10^{-5}) + 120 = 64.8 \text{ dB}$

Therefore, difference in dB = $69.9 - 64.8 = 5.1 \text{ dB}$

Correct answer is B.

Alternate solution:

$$\Delta(\text{dB}) = 10 \log \left(\frac{I_{\text{Joseph}}}{I_{\text{Lim}}} \right)$$

$$= 10 \log \left(\frac{3 \times 10^{-5}}{0.98 \times 10^{-5}} \right)$$

$$= 5.1 \text{ dB}$$

2 marks

Tip

- *Revise and list rules for log operations.*

Use the following information to answer Questions 4 and 5.

Gretel notices a howling sound coming from the side of the cottage. She asks Hansel to investigate, who finds that the sound is coming from a pipe just above the window as air blows through it. The pipe is open at both ends and Hansel measures the frequency to be 312 Hz. Take speed of sound to be 340 ms^{-1} .

Question 4

The length of the pipe is closest in value to

- A. 0.27 m
- B. 0.3 m
- C. 2.1 m
- D. 0.54 m

D

Worked solution

For a pipe open at both ends, the fundamental frequency is

$$\begin{aligned} f_n &= 312 \\ &= n \frac{v}{2L} \\ &= \frac{340}{2 \times L} \end{aligned}$$

$$\therefore L = 0.54 \text{ m.}$$

2 marks

Question 5

When Hansel closes one end of the pipe tightly with pebbles wrapped in old rags, a different but louder frequency is heard. The frequency of this sound is most likely to be

- A. 157 Hz
- B. 130 Hz
- C. 624 Hz
- D. 225 Hz

A

Worked solution

The sound heard is the fundamental note of a closed pipe.

$$\begin{aligned} f_n &= n \frac{v}{4L} \\ &= \frac{340}{4 \times 0.54} \\ &= 157.4 \text{ Hz} \end{aligned}$$

2 marks

Tip

- Recognise that the loudest sound heard in a pipe is the resonance of the fundamental.

SECTION B – Detailed study 3 – continued
TURN OVER

Use the following information to answer Questions 6–9.

Ahmed and Celina wish to set up some loudspeakers in a performance studio. The response graphs for four loudspeakers, P, Q R, and S, are shown in Figure 2, from which they have to select just one loudspeaker for each performance. On a certain evening's performance there will be speeches and some instrumental music. Speech has a frequency range of 300–600 Hz, whereas instrumental music is about 600–2000 Hz.

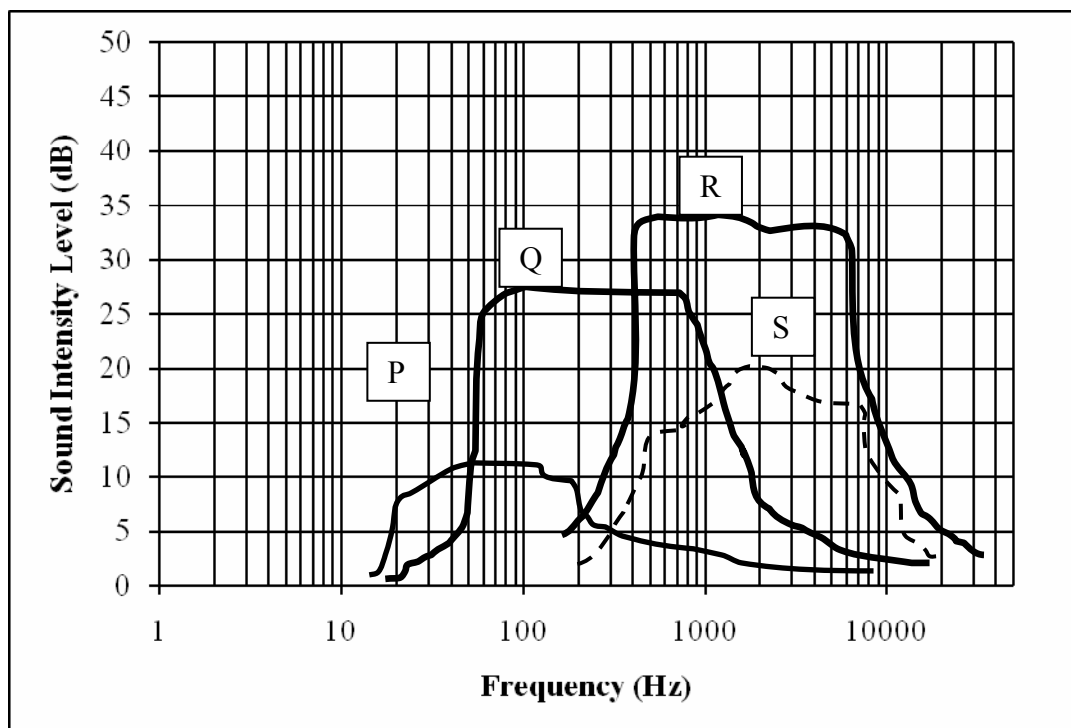

Figure 2

Question 6

Which of the following statements provides the best suggestion for use of the loudspeakers?

- A. Use Q for both speech and instrumental music.
- B. Use Q for speech and R for instrumental music.
- C. Use R for speech and Q for instrumental music.
- D. Use P for both speech and instrumental music.

B

Worked solution

Since speech has a frequency range of 300–600 Hz and instrumental music about 600–2000 Hz, the graph indicates that the best fidelity is obtained when Q is used for speech and R for instrumental music.

2 marks

Question 7

The loudspeaker that has the highest fidelity in the range 500–1000 Hz is

- A. P
- B. Q
- C. R
- D. S

C

Worked solution

Examining the graph, we can see that loudspeaker R has the most linear (flat) graph in the range of 500–1000 Hz. Hence, correct answer is C.

2 marks

Question 8

Ahmed and Celina remove the baffle from around the loudspeaker R before installing it on a wall such that sound waves can now travel around the room from the front and rear of the loudspeaker. When instrumental music is played through it, what will be the most likely effect of removing the baffle?

- A. The sound will be louder for all frequencies.
- B. The sound will be softer for all frequencies.
- C. The fidelity of the loudspeaker will decrease.
- D. The fidelity of the loudspeaker will increase.

C

Worked solution

A baffle prevents the sound waves from the back of a loudspeaker interfering with the waves from the front, thereby providing a higher fidelity sound.

2 marks

Question 9

For an instrumental music rehearsal, all loudspeakers and microphones are turned off. Amy and Raj are standing outside the studio door, as shown in Figure 3.

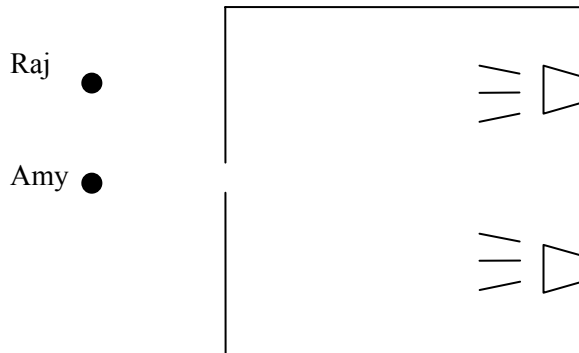
**Figure 3**

Which one of the following statements **best** describes the sound heard by Amy and Raj?

- A. Amy hears more of the higher frequencies than the lower frequencies.
- B. Raj hears all frequencies.
- C. Amy hears all frequencies.
- D. Raj hears more of the higher frequencies than the lower frequencies.

C

Worked solution

The extent of diffraction is proportional to the ratio of wavelength to size of opening. Higher frequencies diffract less.

2 marks

Tips

- *Take care when reading values off fidelity graphs of loudspeakers and microphones as they are often in log scales.*
- *High frequency sounds are very directional.*

Use the following information to answer Questions 10 and 11.

The curves in Figure 4 show the response of a student to different frequencies, each of a pure tone. Each curve represents equal loudness to the student. Note: 1000 Hz is taken as the reference frequency for phons.

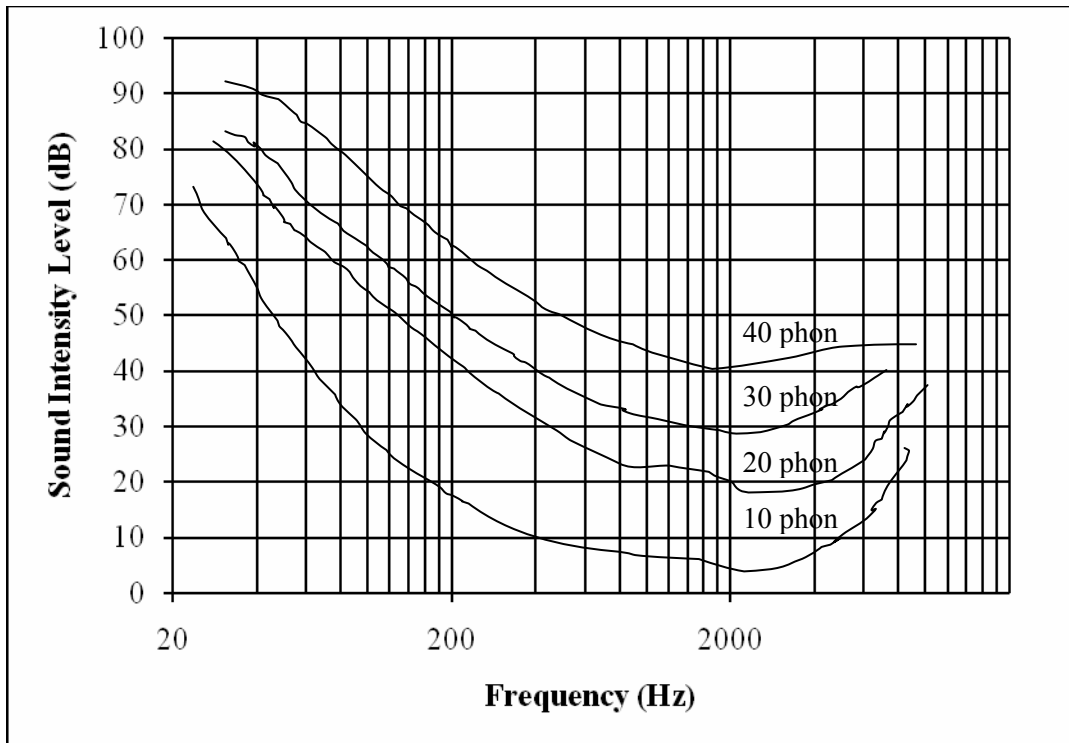

Figure 4

Question 10

What should be the intensity level of a 500 Hz sound for the student to perceive it as having the same loudness as a 40 dB sound?

- A. About 45 dB.
- B. About 40 dB.
- C. About 30 dB.
- D. About 60 dB.

A

Worked solution

Identify 500 Hz on the x -axis. Find the y coordinate of this frequency at 40 phon. Then find the y -axis value of 45 dB as the equivalent loudness.

2 marks

Question 11

What is the frequency at which the student perceives a 30 dB sound to have the same loudness as a 40 dB sound?

- A. About 350 Hz.
- B. About 300 Hz.
- C. About 400 Hz.
- D. About 450 Hz.

B

Worked solution

Start with the curve for 30 phon and trace the path until it intersects the axis at 40 dB. Then find the x coordinate of the intersection as 300 Hz.

2 marks

Tips

- *Work out procedures from the graph to find equivalent loudness values.*
- *Graphs may be in log scales.*

Question 12

Which **one or more** of the following statements describes the operation of a moving coil microphone?

- A. It is based on the principle of air pressure affecting the dimensions of a capacitor, thereby affecting the electrical signal.
- B. The inertia of the coil results in good fidelity at high frequency.
- C. The microphone is very sensitive to air pressure and must not be used in open air.
- D. It is based on the principle of electromagnetic induction.

D

Worked solution

The moving coil microphone has a coil that can move within a magnetic field in proportional response to air pressure variations due to sound waves. Hence, correct answer is D.

2 marks

Tip

- *Make a table showing type of microphones, principle on which each is based, response graph, uses and problems.*

Question 13

A swimming coach issues an instruction to his student, who is swimming underwater. Which one of the following statements best describes the relationship between speed and frequency of the sound wave in air when compared to water?

- A. The speed of sound is greater in air than in water, whereas the frequency of the sound wave is less in water than in air.
- B. The speed of sound is the same in air and in water. The frequency of the sound wave is greater in air than in water.
- C. The speed of sound is less in water than in air. The frequency of the sound wave is unchanged.
- D. The speed of sound is greater in water than in air. The frequency of the sound wave is unchanged.

D

Worked solution

The speed of sound is greater in water than in air because water is denser. The frequency is a property of the source, not the medium, and remains unchanged. The wavelength in water is less than in air.

2 marks

Tips

- *The frequency of a sound wave does not change as it travels from one medium into another.*
- *A denser medium will have a higher speed of sound.*

END OF SOLUTIONS