

THE SCHOOL FOR EXCELLENCE 2006

UNIT 3 PHYSICS

WRITTEN EXAMINATION 1

Reading Time: 15 minutes
 Writing Time: 1 hour 30 minutes

QUESTION AND ANSWER BOOK

Structure of Book

<i>Section</i>	<i>Number of Questions</i>	<i>Number of Questions to be Answered</i>	<i>Number of Marks</i>	<i>Suggested Times (minutes)</i>
A Core Studies				
Motion	16	16	36	36
Electronics and Photonics	14	14	27	27
B Detailed Studies				
1. Einstein's Special Relativity OR	10	10	27	27
2. Structures and Materials OR	10	10	27	27
3. Further Electronics	12	12	27	27
			Total 90	Total 90

COMPLIMENTS OF THE SCHOOL FOR EXCELLENCE

Voted Number One For Excellence and Quality in VCE Programs and Tutorials.

THE SCHOOL FOR EXCELLENCE



The School For Excellence (**TSFX**) is a private educational institution that provides educational services to Year 11 and 12 students. Our services include a variety of intense revision courses before examinations, intense weekly tuition classes, study skills lectures, as well as specialised courses that prepare students in advance of each school term.

The educational programs conducted by **TSFX** are widely recognised for providing the highest quality programs in Victoria today. Our programs are the result of 15 years of collaborative effort and expertise from dozens of teachers and schools across the state, ensuring the highest possible quality resources and teaching styles for VCE students.

For additional information, join our complimentary mailing list at www.tsfx.com.au. Alternatively, please call **TSFX** on (03) 9663 3311 during business hours.

JOIN VCEDGE ONLINE

VCEdge Online is a new educational resource designed to give students the best opportunities to optimise their Year 11 or 12 scores. In addition to the abundant collection of **FREE** materials on this site, **VCEdge Online** members receive over \$300 worth of resources, including:

- Subject notes and course summaries.
- Sample A+ SACS and SATS.
- Trial examinations with worked solutions.
- Weekly study tips and exam advice.
- Two FREE tickets into an intense examination strategy lecture (valued at \$200!!!).
- Cheat sheets and cards.
- Critical VCE updates.
- Free VCE newsletters.
- Information on upcoming educational events.
- And much, much more!!!

JOIN FREE OF CHARGE AT WWW.TSFX.COM.AU

SECTION A – CORE STUDIES

The following constants are relevant to this paper:

For calculations: $g = 9.8 \text{ m s}^{-2}$
Unless stated otherwise; ignore air resistance.

AREA OF STUDY 1 – MOTION IN ONE AND TWO DIMENSIONS

Questions 1 to 4 refer to the following information:

A trolley of mass 6.0 kg is given a push and then allowed to roll freely along a bench. Its velocity is then measured continuously and graphed (Figure 1). At time 1.5 seconds a lump of clay is dropped into the trolley.

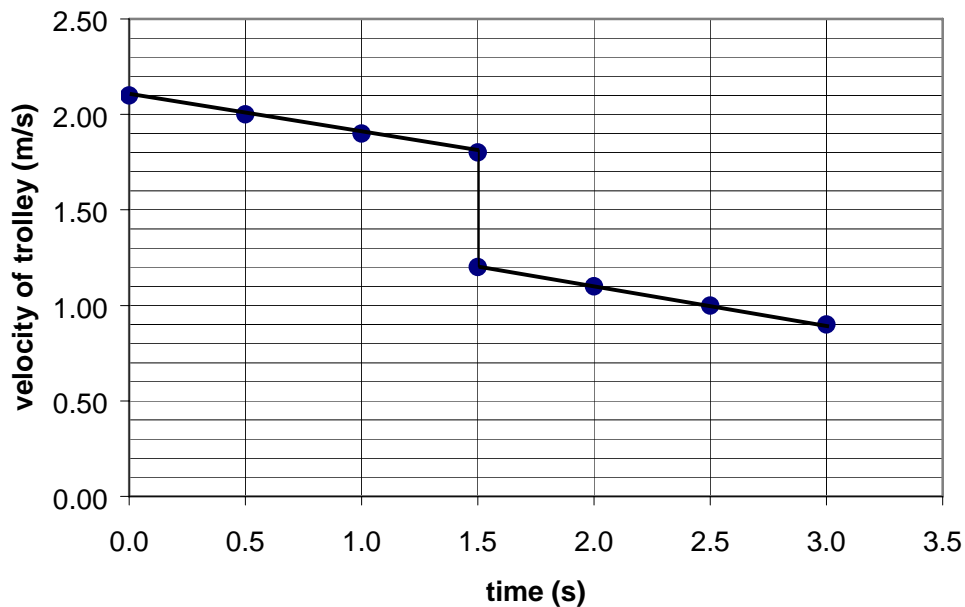

Figure 1

QUESTION 1

What is the magnitude of the frictional force acting on the trolley over the first 1.5 seconds?

N

2 marks

QUESTION 2

How much work was done by the frictional force in this first 1.5 seconds?

J

2 marks

QUESTION 3

What was the mass of the lump of clay that was dropped into the trolley?

kg

2 marks

QUESTION 4

Note that the slope of the graph is the same both before and after the addition of the clay.
From this it may be deduced that the magnitude of the frictional force:

- A Is constant.
- B Decreases linearly with time.
- C Is directly proportional to the weight.
- D Decreases linearly with the velocity.

--

2 marks

QUESTION 5

Which of the following statements about an airbag is **not** true?

- A The airbag increases the deceleration of the passenger's head.
- B The airbag increases the distance in which the passenger's head comes to rest.
- C The force constant of the airbag is less than that of most of the alternative surfaces that the passenger's head may contact.
- D The airbag increases the time in which the passenger's head comes to a rest.



2 marks

Questions 6 and 7 refer to the following information:



In a Physics experiment an ultra light aircraft flies due west away from its shelter with a steady speed of 48 m s^{-1} .

A strong northerly (from the north) wind blows at a consistent 14 m s^{-1} .

QUESTION 6

What is the velocity of the aircraft relative to the shelter?

3 marks

Magnitude:	<input type="text"/>	m s^{-1}
------------	----------------------	-------------------

Direction:	<input type="text"/>
------------	----------------------

QUESTION 7

What is the magnitude of the velocity of the shelter relative to the aircraft?

1 mark

m s⁻¹

Questions 8 and 9 refer to the following information:

Assume that the 7.3 kg ball being swung in Figure 2 according to the “hammer-throw” event is actually moving in a horizontal circle. It is moving with a speed of 15 m s⁻¹ with a radius of curvature of 2.5 m.



Figure 2

QUESTION 8

In the reproduction of Figure 2 below, which **2** arrows best indicate the directions of forces acting on the ball during this rotation and which arrow best indicates the direction of the resultant force?

Two acting forces:

Resultant force:

3 marks

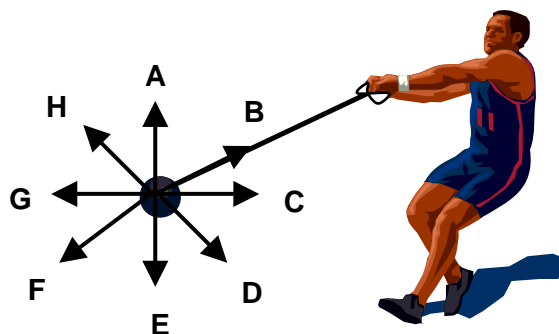

Figure 2

QUESTION 9

What is the magnitude of the net force acting on the ball?

N

2 marks

Questions 10 to 13 refer to the following information:

At the recent Commonwealth games, Scott released a shot-put at 10.0 m s^{-1} at an angle of 37° above the horizontal. The time of flight was 1.48 seconds. Figure 3 shows the flight of the shot-put (not to scale).

(Air resistance should be neglected in calculations.)

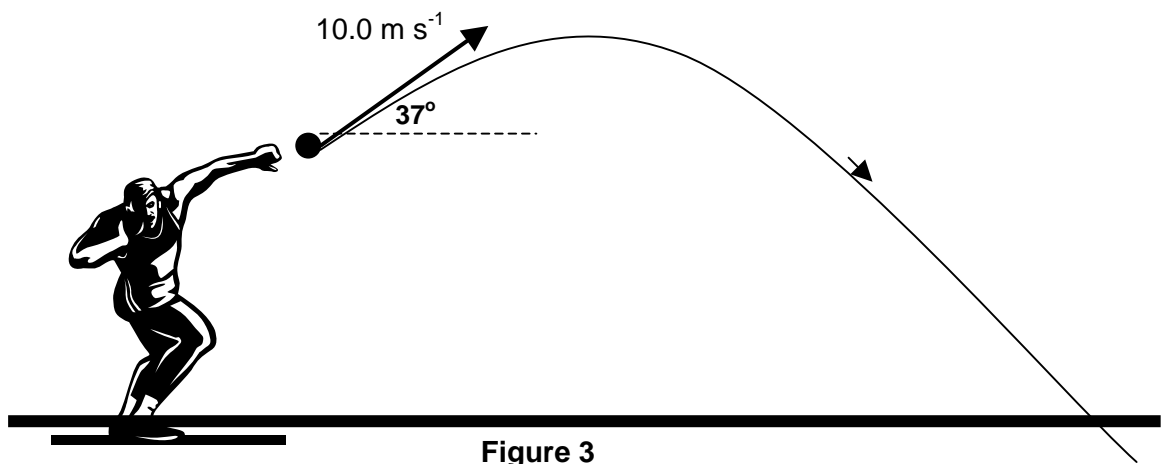

Figure 3

QUESTION 10

What was the magnitude of the horizontal component of the release velocity?

m s^{-1}

2 marks

QUESTION 11

What was the horizontal distance that the shot-put landed from the point of release?

m

2 marks

QUESTION 12

If the shot-put was released from a height of 1.85 m above the ground, what would be its velocity on landing?

m s^{-1}

3 marks

QUESTION 13

Which of the following diagrams (A to D) correctly shows the direction of the **resultant force** on the shot-put at the position of maximum height in the **real** situation where **air resistance cannot be ignored**?

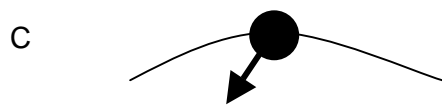

2 marks

Questions 14 to 16 refer to the following information:

The K-lab spacecraft (mass = 8.25×10^3 kg) travelled past Jupiter **with its engines off**.

Figure 4 shows how the force of gravity on K-lab varied according to its distance from the center of Jupiter.

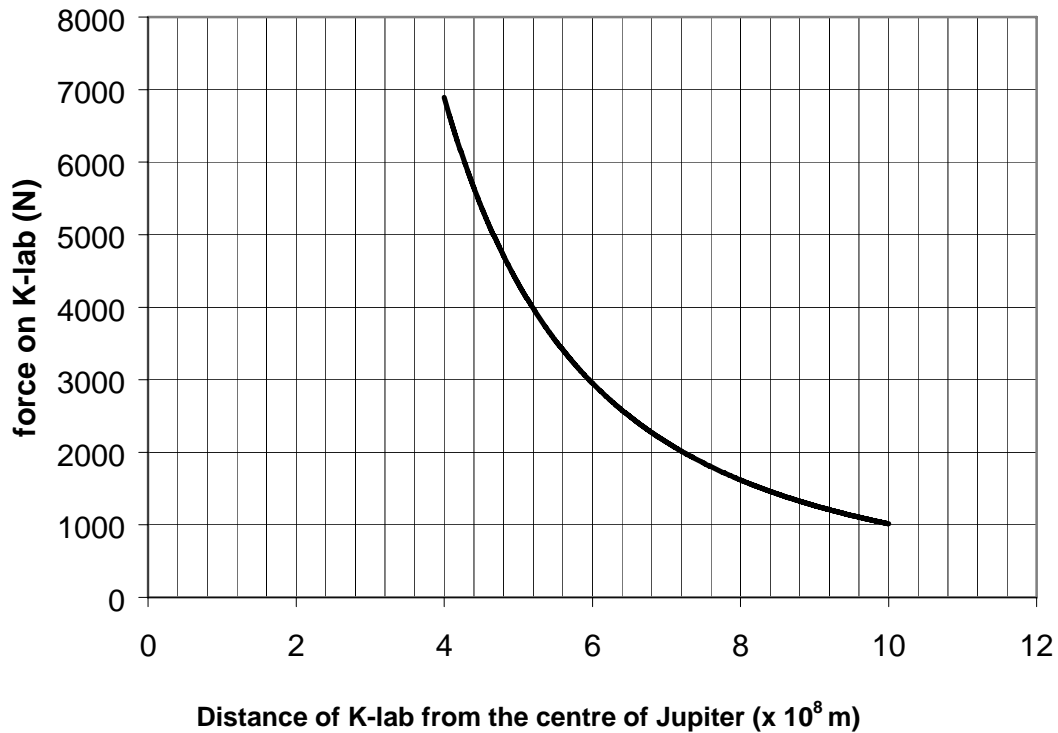

Figure 4

QUESTION 14

What is the gravitational field strength when 5.2×10^8 m from the centre of Jupiter?

2 marks

N kg^{-1}

QUESTION 15

Estimate the decrease in gravitational potential energy as K-lab moved from a distance of 7.2×10^8 m from the centre of Jupiter in to a distance of 5.2×10^8 m from the centre of Jupiter.

J

3 marks

QUESTION 16

Given that K-lab had a speed of 1.33×10^4 m s⁻¹ when 7.2×10^8 m from the centre of Jupiter, what would its speed have been when at a distance of 5.2×10^8 m from the centre of Jupiter?

m s ⁻¹

3 marks

AREA OF STUDY 2: ELECTRONICS AND PHOTONICS

The following information applies to Questions 1 – 4.

The graph below shows the current-voltage characteristics for an LED connected in series with a 100 ohm resistor.

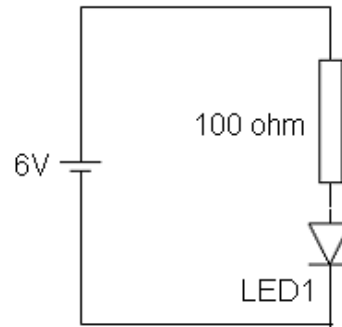
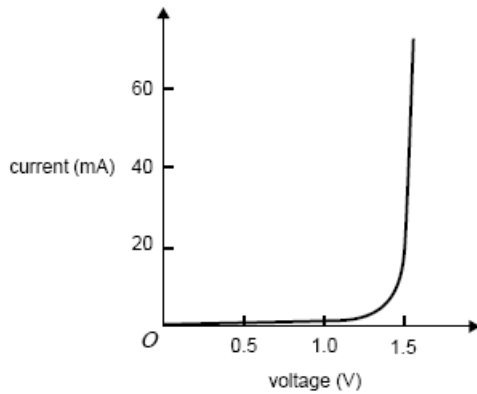

QUESTION 1

What is the current through the LED?

mA

2 marks

QUESTION 2

Which of the following is a correct statement regarding the energy conversion in the circuit?
All of the energy from the battery is converted to:

- A. to heat energy in the LED and the resistor.
- B. to heat energy in the resistor and light energy in the LED.
- C. to heat and light energy in the LED.
- D. to heat energy in the resistor with heat and light energy in the LED.

--

2 marks

A second identical LED is arranged in parallel to the original

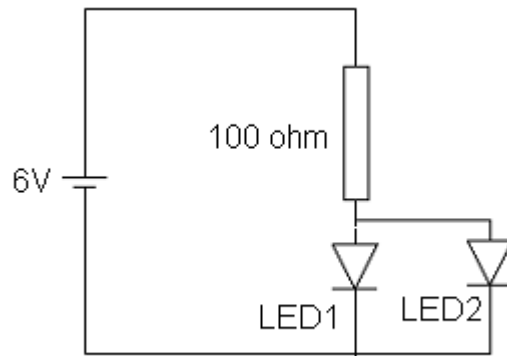

QUESTION 3

What is the current through each LED?

mA

2 marks

QUESTION 4

What is the power dissipated in each LED. Show your working and express your answer in mW.

mW

2 marks

The following information applies to Questions 5 – 10.

The graph below shows the variation in resistance of a light dependent resistor (LDR) with changes in light intensity i.e. an illumination of 10^5 lux produces a resistance of 10^2 ohms.

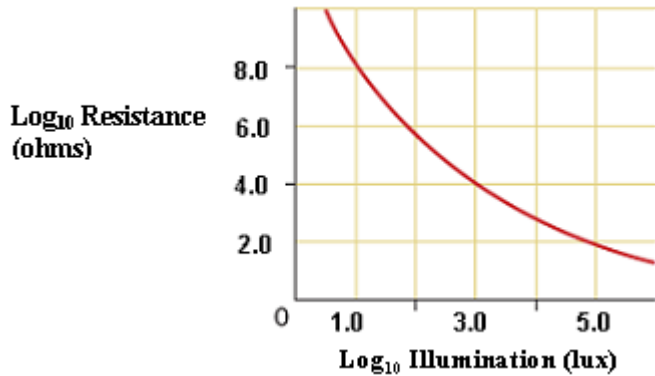

QUESTION 5

What is the resistance of the LDR when the light level is 10^3 lux?

ohms

1 mark

The LDR is connected in series with resistor R1 to form a voltage divider. The output of the voltage divider provides a bias voltage to an npn transistor that controls the state of an LED night light. The night light should automatically turn on when it starts to get dark. The circuit is shown below.

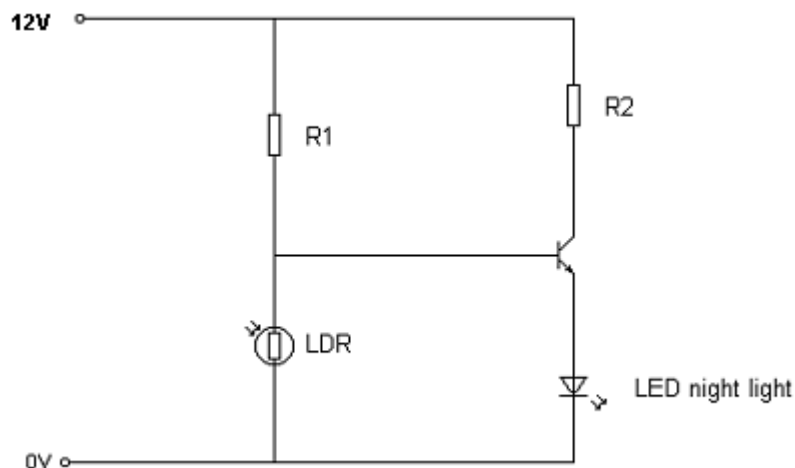

The following graph shows the characteristics of the night light.

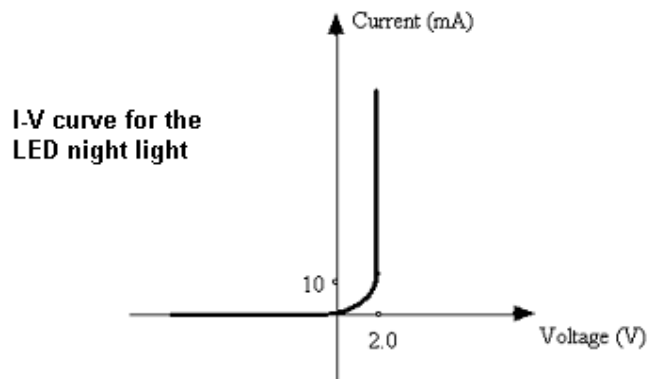

A minimum of 10 mA is required for the night light to glow brightly.

QUESTION 6

If a correctly biased npn transistor requires a potential difference of 0.7 V across the base-emitter, what minimum voltage should be applied to the base pin of the transistor in order for the night light to operate properly?

V

2 marks

QUESTION 7

It was decided that 10^3 lux should be the light level that switches on the night light. What should be the value of resistor R1?

ohms

2 marks

QUESTION 8

Would the night light circuit work satisfactorily if the positions of R1 and the LDR were reversed? Explain your answer.

2 marks

QUESTION 9

What would be the benefit in replacing resistor R1 with a variable resistor?

2 marks

This is the V_{IN} versus V_{OUT} transfer characteristic for a voltage amplifier.

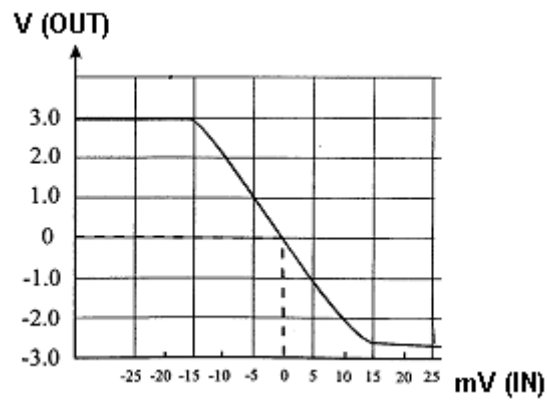

QUESTION 10

Calculate the voltage gain of the amplifier

2 marks

QUESTION 11

Is this an inverting or a non-inverting amplifier? Explain your reason.

2 marks

The following circuit is used to amplify the analogue voltage input from a microphone.

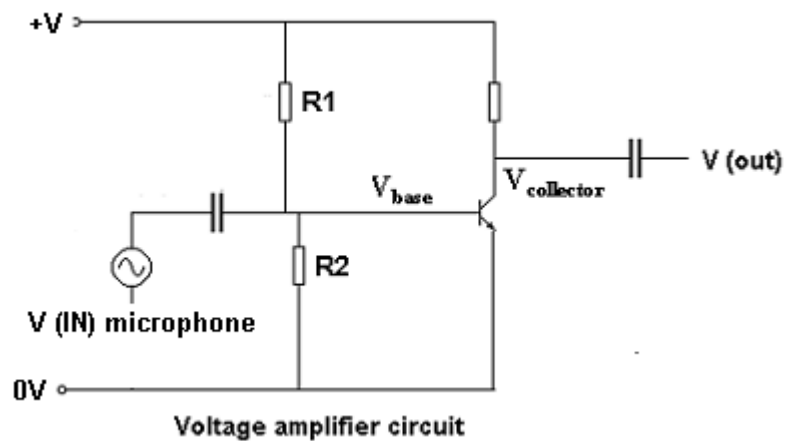
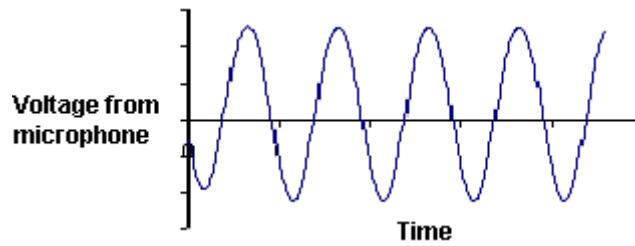

One lead from a cathode ray oscilloscope is connected to the 0 V rail and the other end connected to $V_{collector}$ in order to view the amplified voltage waveform.

QUESTION 12

On the axes provided, draw at least two wavelengths of the expected waveform (specific values are not required).



2 marks

QUESTION 13

One lead is now moved from the collector to V (OUT) whilst the other remains connected to the 0 V rail. Draw the expected waveform that would now be viewed on the CRO.



2 marks

QUESTION 14

The following is a phototransistor circuit.

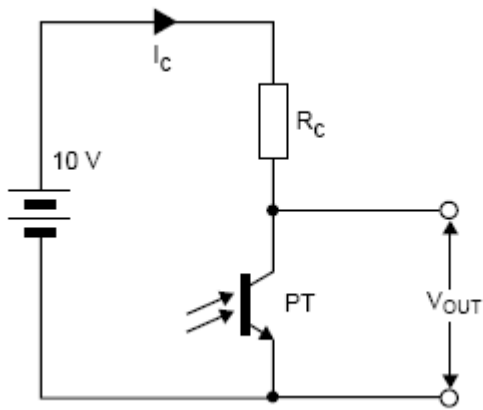

Which of the following statements is correct when the light intensity on the phototransistor decreases:

- A. The collector current increases, but V_{OUT} increases.
- B. The collector current decreases, but V_{OUT} increases.
- C. The collector current remains constant but V_{OUT} increases.
- D. The collector current remains constant but V_{OUT} decreases.

2 marks

SECTION B – DETAILED STUDIES

Instructions For Section B

Choose one of the following **Detailed Studies**. Answer all the questions on the **Detailed Study** you have chosen.

DETAILED STUDY 1 - EINSTEIN'S SPECIAL RELATIVITY

QUESTION 1

Circle the most appropriate component of each **bold** component in the passage below.

Einstein's theory of Special Relativity states that all the laws of physics are the same in all reference frames that have constant **speed/ acceleration/ velocity**.

It also says that the speed of light in a vacuum has the same value **always/ in all inertial reference frames/ when travelling close to the speed of light**.

These postulates of special relativity give rise to a range of consequences including time dilation, which means for a stationary observer, a moving clock runs **faster/same/slower** than an identical stationary clock.

3 marks

QUESTION 2

Which of the following A – D best describes the purpose of the Michelson-Morley experiment?

- A. To measure the speed of light with respect to the Earth
- B. To measure the speed of the Earth with respect to the ether
- C. To measure the speed of the ether with respect to light
- D. To measure the speed of wind with respect to the Earth.

2 marks

Alain and Bernie are discussing whether it is valid to consider the effects of relativity for a ball travelling at 50 m/s.

QUESTION 3

Is it valid to consider relativistic effects for this ball? Explain your answer giving support from calculations.

4 marks

In a thought experiment, Alain and Bernie then went on to consider what would happen if the ball, with dimensions height, h , and length, l , were to travel at a constant speed, v , 80% the speed of light as shown in the diagram below.

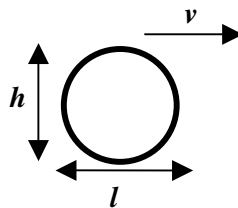

QUESTION 4

Which of the following (A-D) best describes the length of the ball along its direction of motion as seen by Alain and Bernie in a stationary reference frame?

- A $1.7l$
- B l
- C $0.8l$
- D $0.6l$

2 marks

QUESTION 5

Which of the following (A-D) best describes the height of the ball as seen by Alain and Bernie in a stationary reference frame?

- A $1.7h$
- B h
- C $0.8h$
- D $0.6h$

2 marks

The pi meson has an average lifetime of 2.6×10^{-8} s in its own reference frame. Yet the scientists in the laboratory measure the average life-time to be 5.96×10^{-8} s.

QUESTION 6

At what speed is the pi meson travelling? Give your answer in units of c .

4 marks

QUESTION 7

What distance does the pi meson travel in a life-time according to the measurements of the scientists?

m

2 marks

A proton in a particle accelerator is accelerated from rest to a speed of $0.8 c$. The rest mass of the proton is $1.67 \times 10^{-27} \text{ kg}$.

QUESTION 8

What is the relativistic mass for this proton?

kg

2 marks

The proton is now accelerated further to have a kinetic energy of 5.34×10^{-10} J.

QUESTION 9

Which of the following (A-D) is the work done on this proton to accelerate it from rest?

- A 6.84×10^{-10} J
- B 5.34×10^{-10} J
- C 3.84×10^{-10} J
- D 1.50×10^{-10} J

2 marks

QUESTION 10

Determine the new speed of the proton, given the kinetic energy above, according to *Newtonian* mechanics and *briefly* comment on the validity of the speed.

4 marks

DETAILED STUDY 2 - INVESTIGATING MATERIALS AND THEIR USE IN STRUCTURES

A frame constructed from lightweight pieces of timber bolted together as shown, is used to support a 10 kg sign. The frame is attached to a post at M and N.

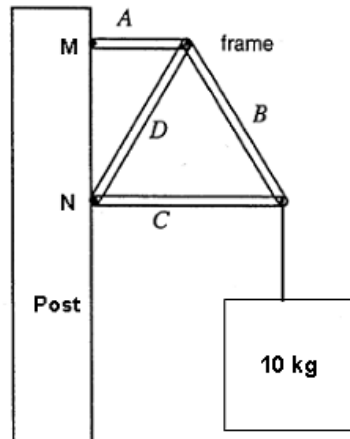

QUESTION 1

Identify whether the forces acting along each piece of timber are in tension, compression or are force neutral (neither in tension or compression)

Timber A: _____

Timber B: _____

Timber C: _____

Timber D: _____

4 marks

QUESTION 2

Draw a diagram to represent the 3 forces subsequently acting on Timber A. The forces must be drawn to show the direction in which they act and the points at which they act.

3 marks

A sandstone pillar of cross-sectional area 0.02 m^2 is used to support a statue.

A graph of stress against strain for the sandstone column is shown below:

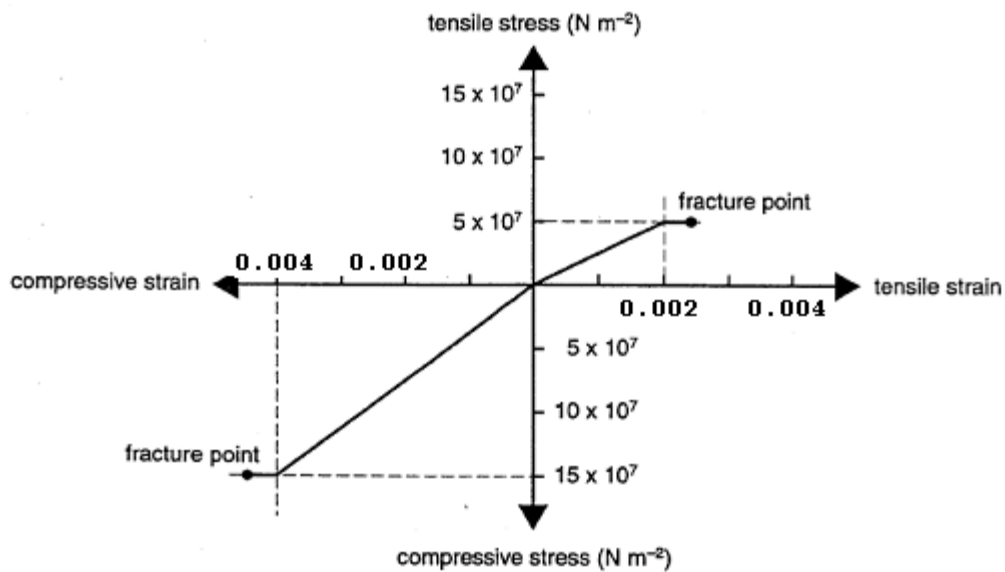

QUESTION 3

What is the mass of the heaviest statue that the pillar can just support without breaking?

kg

3 marks

QUESTION 4

What is the value of Young's modulus for sandstone under compression?

kg

2 marks

QUESTION 5

Use information from the stress-strain graph to compare the strength of sandstone under compression and tension.

3 marks

QUESTION 6

Sandstone is not particularly suited to applications where it will be placed under shear stress.

Which of the following statements best describes shear stress?

- A The forces act to pull all atoms further apart.
- B The forces act to slide adjacent layers of atoms over each other.
- C The forces act to push all atoms closer together.
- D The forces act to push adjacent layers of atoms closer together.

--

2 marks

The stress-strain curves for four materials are shown below. All four materials have the same stress at their elastic limit, which is indicated by ■, and the point of fracture by ★.

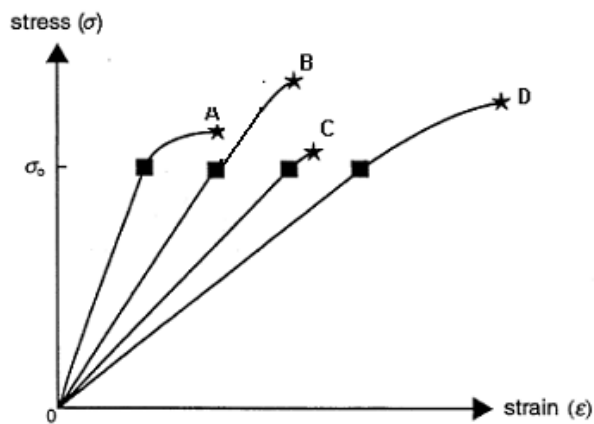

QUESTION 7

Which of the four materials (A-D) is the most brittle? Explain why you selected it.

2 marks

QUESTION 8

Within the elastic regions, which of the four materials (A-D) is the stiffest? Explain why you selected it.

2 marks

QUESTION 9

Which of the four materials (A-D) shows the most toughness? Explain why you selected it.

2 marks

A person of mass 80 kg stands 1.5m from the end of a 6.0 m long beam of mass 10 kg. The beam is supported at each end (use $g = 9.8 \text{ Nm}^{-2}$).

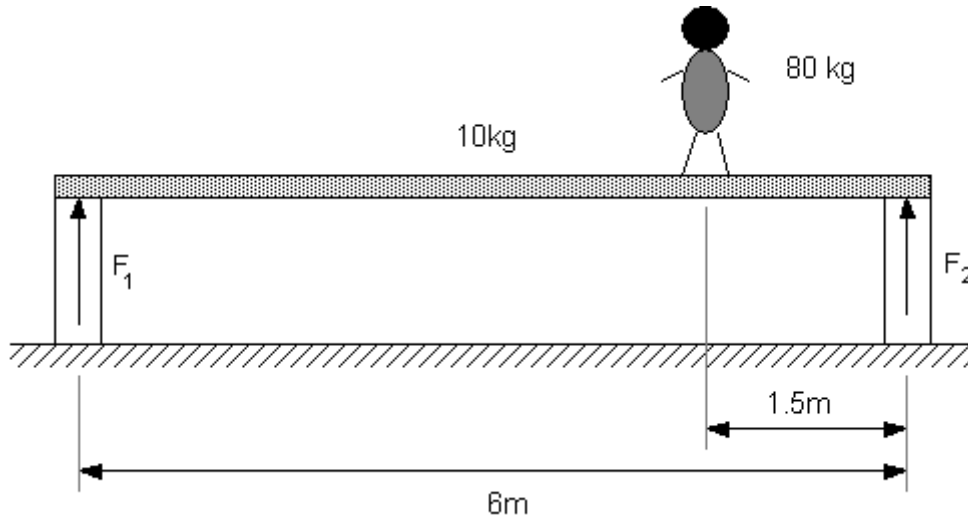

QUESTION 10

Calculate the size of the forces F_1 and F_2 that are supporting the beam.

4 marks

DETAILED STUDY 3 - FURTHER ELECTRONICS

A student is asked to describe the main components and function of a regulated DC power supply. He writes his first draft with a number of phrases he is unsure about.

QUESTION 1

Read the student's speech and circle the correct component of each **bolded** section so that the speech is correct.

"A regulated power supply should be used to transform an alternating current supply into a **source of constant voltage/ half wave power supply/fully rectified power supply**.

A transformer is used to **increase/decrease/rectify** the supply voltage before it is placed across a **bridge rectifier/capacitor/load**.

A zener diode is used to complete the circuit. The zener diode is used in **forward biased orientation /reverse biased orientation/ inverted orientation.**"

4 marks

The student constructs the voltage regulator starting with the transformer. He wants to convert a 240 AC power supply to a 20 AC V power supply.

QUESTION 2

Calculate the value of the ratio:

$$\frac{\text{Number of turns on the primary coil}}{\text{Number of turns on the secondary coil}}$$

2 marks

The student decides to use a circuit as shown in Figure 1a to view the output of the transformer output of the circuit V_{OUT} . Figure 1b shows the voltage he views at the output of the transformer $V_{SECONDARY}$.

Transformer:

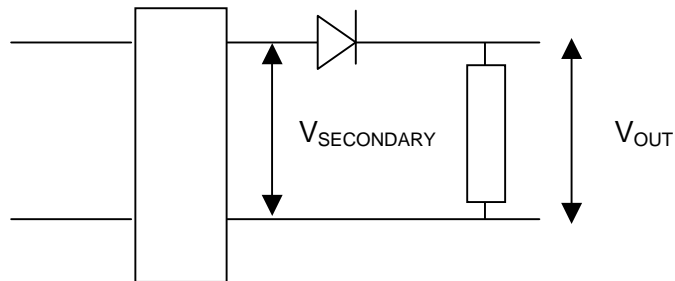

Figure 1a

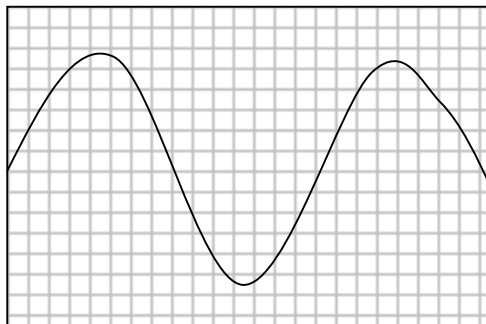

Figure 1b

QUESTION 3

From the following statements (A-D), choose the best description of the frequency of the voltage signal V_{out} .

- A The frequency will be unchanged.
- B The frequency will be slightly smaller because the Diode takes power.
- C The frequency will be slightly smaller due to damping by the diode.
- D The frequency will be slightly higher due to interactions with the CRO wires.

2 marks

QUESTION 4

Choose from the following statements (A-D) the best description of the amplitude of the voltage signal V_{out}

- A Amplitude will be unchanged.
- B Amplitude will be slightly smaller due to the diode's threshold voltage.
- C Amplitude will be slightly smaller due to heat loss in the connection wires and CRO.
- D Amplitude will be slightly larger due to resonant oscillations in the diode circuit.

2 marks

QUESTION 5

Choose the best representation of the voltage signal V_{out} using this circuit (A-D).



2 marks

The student now attempts to use a rectifier bridge in the circuit using 4 diodes.

QUESTION 6

Using the outline of the bridge in Figure 2, draw the orientation of the 3 other diodes and which would allow the AC voltage to be completely rectified.

Figure 2

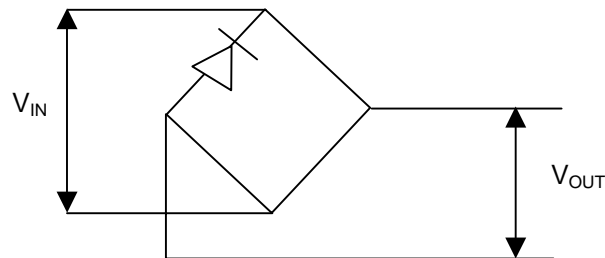

1 mark

The input voltage to the rectifier V_{IN} is viewed using a Cathode Ray Oscilloscope of time base 0.5 ms. The results are represented in Figure 3.

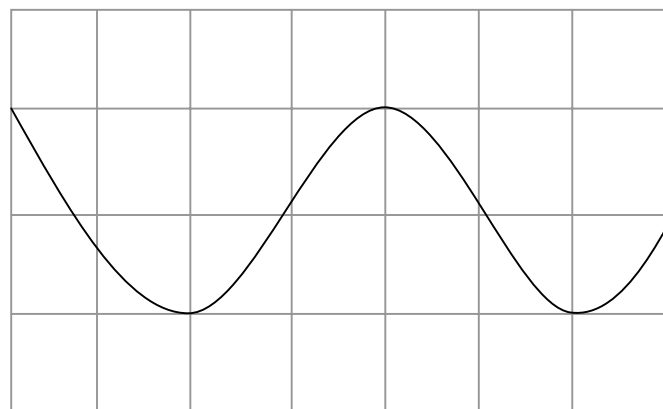

Figure 3

QUESTION 7

Calculate the frequency of the input signal

Hz

2 marks

QUESTION 8

Using Figure 3 as a guide, sketch the likely output V_{out} of the rectifier.

2 marks

The student now adds a capacitor and a load resistor to the circuit as shown in Figure 4.

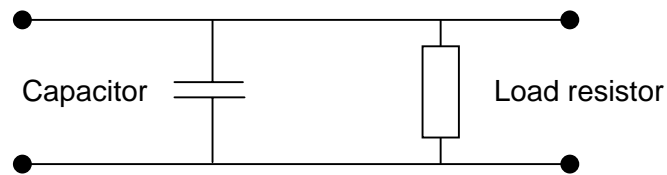

Figure 4

The load resistor being used is 40Ω and the capacitor chosen is $50 \mu F$.

QUESTION 9

Calculate the time constant for this capacitor resistor combination.

ms

2 marks

QUESTION 10

The student states that this scenario would be ideal to smooth the rectified output and reduce the ripple. Is the student correct or incorrect in his assumption? Circle your response in the options listed below. Explain your answer (refer to the output voltage and the time constant to support your answer).

Correct / Incorrect / A Clear Decision Cannot Be Made

4 marks

Some electronic circuits require very tightly regulated supplies. One such device is a zener diode.

QUESTION 11

Which one or more of the following statements about a zener diode (A-D) are correct?

- A A zener diode is a special diode designed to break down at low reverse voltage.
- B A zener diode is a special diode designed to break down at high reverse voltage.
- C A zener diode will be damaged if the power dissipated through is not limited.
- D A zener diode will be damaged if it breaks down under reverse bias conditions.

2 marks

Integrated circuit regulators are sometimes used to provide a very low ripple voltage supply.

QUESTION 12

Which of the following statements (A-D) about integrated circuit regulators are correct?

- A Very few additional components are required to use the IC Regulator.
- B Catastrophic failure can occur if too much current is not regulated using a buffer resistor before the regulator.
- C The IC regulator needs a heat sink because it will not shut down when it gets too hot.
- D Over current and thermal protection features only protect the regulator, not the rest of the circuit.

2 marks

End of Paper