



**Victorian Certificate of Education
2004**

SUPERVISOR TO ATTACH PROCESSING LABEL HERE

STUDENT NUMBER

Figures

Words

Letter

--

PHYSICS – PILOT STUDY

Written examination 2

Wednesday 10 November 2004

Reading time: 9.00 am to 9.15 am (15 minutes)

Writing time: 9.15 am to 10.45 am (1 hour 30 minutes)

QUESTION AND ANSWER BOOK

Structure of book

<i>Section</i>	<i>Number of questions</i>	<i>Number of questions to be answered</i>	<i>Number of marks</i>
A – Core – Areas of study			
1. Interactions of light and matter	11	11	25
2. Electric power	16	16	40
B – Detailed studies			
1. Synchrotron and applications	10	10	25
OR			
2. Photonics	10	10	25
OR			
3. Recording and reproducing sound	10	10	25
			Total 90

- Students are permitted to bring into the examination room: pens, pencils, highlighters, erasers, sharpeners, rulers, up to two pages (one A4 sheet) of pre-written notes (typed or handwritten) and an approved graphics calculator (memory cleared) and/or one scientific calculator.
- Students are NOT permitted to bring into the examination room: blank sheets of paper and/or white out liquid/tape.

Materials supplied

- Question and answer book of 37 pages, with a detachable data sheet in the centrefold.

Instructions

- Detach the data sheet from the centre of this book during reading time.
- Write your **student number** in the space provided above on this page.
- Answer all questions in the spaces provided.
- **Always** show your working where space is provided because marks may be awarded for this working.
- All written responses must be in English.

Students are NOT permitted to bring mobile phones and/or any other electronic communication devices into the examination room.

SECTION A – Core

Instructions for Section A
 Answer **all** questions **for both** Areas of study in this section of the paper.

Area of study 1 – Interactions of light and matter

A group of students is investigating the photoelectric effect. The apparatus consists of a polished caesium metal plate enclosed in an evacuated clear tube. The plate is illuminated by several different light sources. A retarding potential from a variable power supply is used to stop emitted photoelectrons and hence determine their maximum kinetic energy. An ammeter is used to measure the current of the emitted photoelectrons.

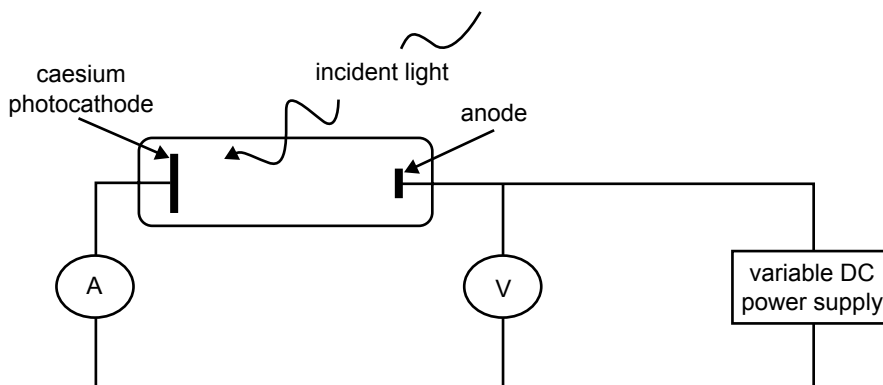

Figure 1

Their results are summarised in Table 1 below. Note that some entries are missing from the table.

Table 1

Colour	Frequency ($\times 10^{14}$ Hz)	Energy of photon (eV)	Maximum kinetic energy (eV)	Maximum current (mA)
red	4.8	2.0		
green	5.4		0.1	0.2
blue	7.3	3.0	0.9	
UV	10.1	4.2	2.1	4.2
UV2	12.0			

Question 1

Use the results above to estimate the work function for caesium metal.

eV

2 marks

Question 2

Calculate the energy of an individual photon in the green light source.

$$(h = 4.14 \times 10^{-15} \text{ eV s}, h = 6.63 \times 10^{-34} \text{ J s}, c = 3.00 \times 10^8 \text{ m s}^{-1})$$

eV

2 marks

The next question relates to the missing entry in the current data when the blue light source was used.

Question 3

Which one of the following statements is true?

The maximum current is dependent on the

- A. intensity of the incident light.
- B. frequency of the incident light.
- C. photon energy of the incident light.
- D. wavelength of the incident light.

--

2 marks

Question 4

- a. Use the data from Table 1 in Question 1 to graph the maximum kinetic energy of the photoelectrons as a function of frequency in the range 3.0×10^{14} Hz to 12.0×10^{14} Hz.

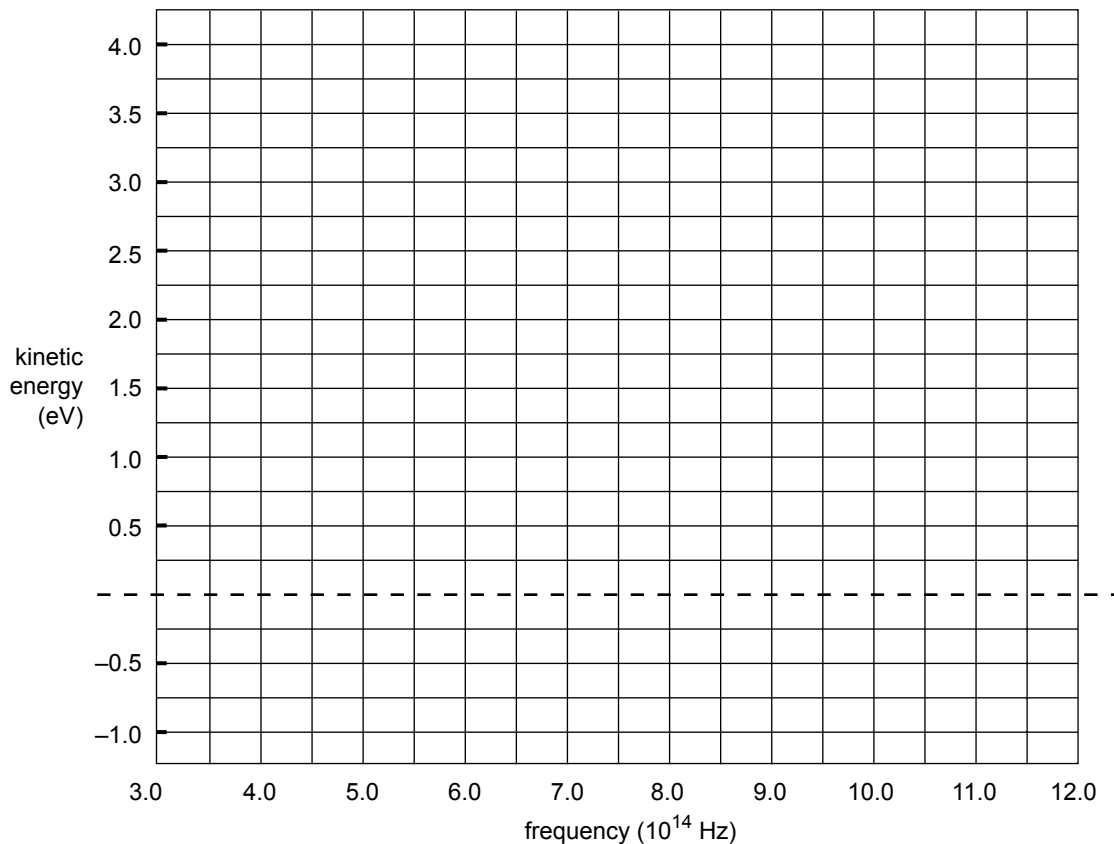

- b. Use your graph to estimate the maximum kinetic energy of the photoelectrons for the red and UV2 sources by extrapolating the experimental results in Table 1. If no electrons are emitted, write N/A in the appropriate box.

red	eV
-----	----

UV2	eV
-----	----

1 + 2 = 3 marks

Figure 2 shows the energy levels of a mercury atom. The atom is initially in the **2nd** excited state.

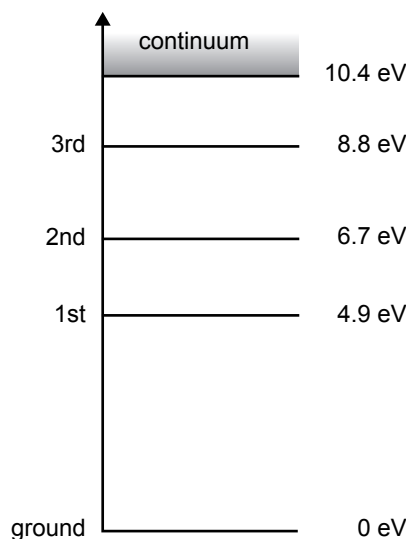

Figure 2

Question 5

Which **one or more** of the following photon energies can be emitted by a mercury atom which is initially in its **2nd excited** state?

- A. 8.8 eV
- B. 4.9 eV
- C. 2.1 eV
- D. 1.8 eV

2 marks

Question 6

A mercury atom is initially in the 2nd excited state.

Which one of the following photon energies could be absorbed by this atom and hence excite it into the **3rd excited** state?

- A. 8.8 eV
- B. 4.9 eV
- C. 2.1 eV
- D. 1.8 eV

1 mark

Figure 3a is the image obtained by scattering electrons off a collection of many small crystals with random orientation. Figure 3b, which is reproduced to the same scale, is the diffraction image obtained with the scattering of x-rays rather than electrons. The x-rays have a wavelength of 35 pm.

**Question 7**

The scattering of electrons and x-rays produces similar diffraction patterns.

Which one of the following best explains why this occurs?

- A. they have the same wavelength
- B. they have the same frequency
- C. they have the same speed
- D. they have the same energy

2 marks

Question 8

Calculate the momentum of the electrons in Figure 3. Make sure you include units in your answer.

$$(m_e = 9.1 \times 10^{-31} \text{ kg}, h = 6.63 \times 10^{-34} \text{ J s}, c = 3.0 \times 10^8 \text{ m s}^{-1})$$

3 marks

Jac and Jules are observing a demonstration of Young’s double slit experiment. Their teacher, Mel, has set up a He-Ne laser of wavelength 632 nm and directed the beam onto a set of two parallel slits. A pattern from these slits has been projected onto a distant wall (Figure 4).

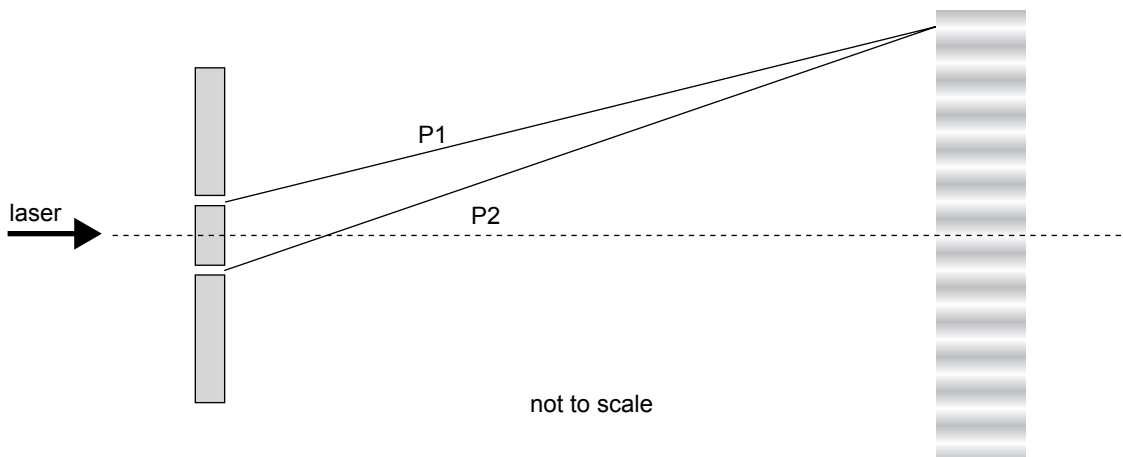

Figure 4

Question 9

Explain the formation of the bright and dark regions in terms of the wavelike nature of light.

3 marks

The teacher asks each student to estimate the difference between the length of the lines P1 and P2, which are the lines between the centre of each slit and the 6th bright spot.

Question 10

Estimate the difference in length between P1 and P2.

--

m

3 marks

Question 11

Which one of the following best represents the 'standing wave' state of an electron in a hydrogen atom where the circumference is equal to four wavelengths?

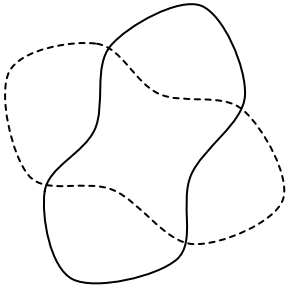
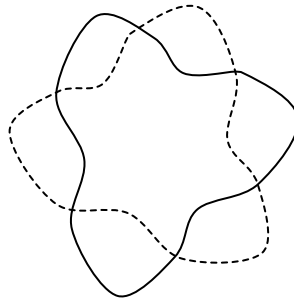
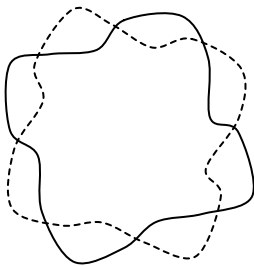
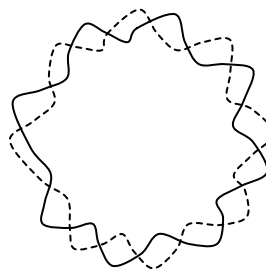
A.**B.****C.****D.**

2 marks

Area of study 2 – Electric power

Jane has been asked to give a short talk on electric power. Listed below are some key parts of her speech. Help her prepare the speech by choosing the best alternative for the options.

Question 1

In the following indicate the answer by circling the best choice from the bolded options.

*If a current-carrying wire is placed in a magnetic field, the wire experiences a force that is maximum when the wire and magnetic field are **[parallel / perpendicular]** to each other.*

*In a similar way, when a magnet is passed repeatedly through a coil of wire, the changing **[electric / magnetic]** field induces voltage across the coil. This is called electromagnetic induction. Increasing the speed at which the magnet passes through the coil **[increases / reduces / does not change]** the amount of electromagnetic induction.*

3 marks

A 10 mm section of a conducting wire is placed in a uniform magnetic field as shown in Figure 1 below. A DC current of $I = 1.0 \text{ A}$ produces a force of 0.01 N and stretches the wire.

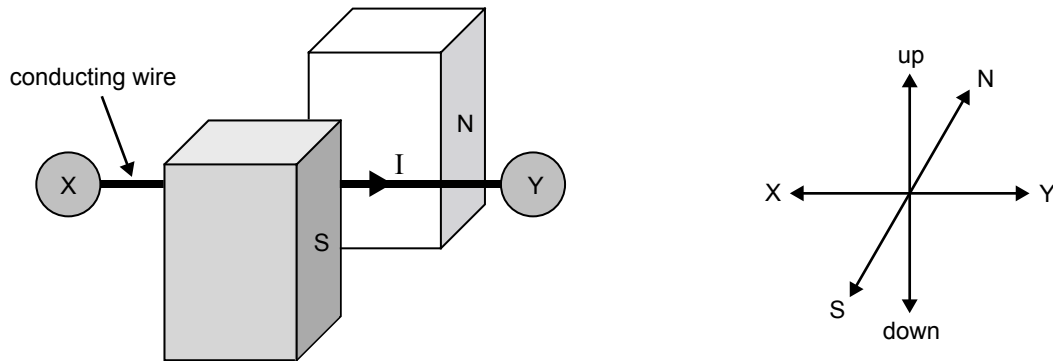

Figure 1

Question 2

Which one of the following options best describes the direction of the resulting force on the wire?

- A. up
- B. down
- C. towards N
- D. towards S
- E. towards X
- F. towards Y

2 marks

Question 3

Calculate the strength of the magnetic field.

 T

2 marks

Question 4

The wire is connected to an AC power source of the same RMS voltage and frequency 100 Hz instead of a DC source.

Briefly explain what happens to the wire.

2 marks

A transformer as shown in Figure 2 below is being tested. The primary coil is connected to a battery and switch. The switch is initially open and no current is flowing in the primary coil. An ammeter is connected to the secondary coil and initially shows no deflection. When the switch is **first** closed, the ammeter needle is deflected to the right and then returns to its initial position of no deflection.

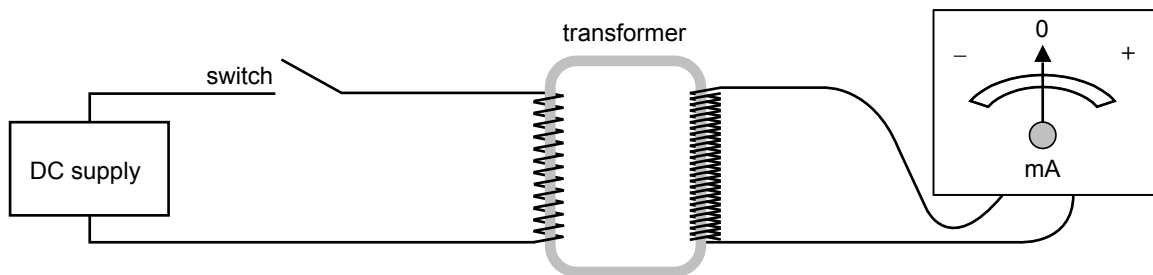

Figure 2

Question 5

Explain why the meter deflects when the switch is closed and then returns to the undeflected position.

2 marks

The switch, which has been closed for a short time, is now returned to the open position and remains open.

Question 6

Which one of the following best describes what happens to the reading of the ammeter?

- A. it deflects to the left and stays at this position
- B. it deflects to the right and stays at this position
- C. it deflects to the left and returns to the middle position
- D. it deflects to the right and returns to the middle position
- E. it does not change

2 marks

Kris is investigating a generator. The magnets are attached to a shaft and are free to rotate around the fixed coil as shown in Figure 3. In this test, the shaft is connected to an electric motor and rotated at a constant speed. Figure 4 below shows the magnetic flux inside the coil. At a speed of 10 revolutions (rotations) per second (rps), the 40-turn coil produces an emf of $2.0 \text{ V}_{\text{RMS}}$, and the light globe glows dimly.

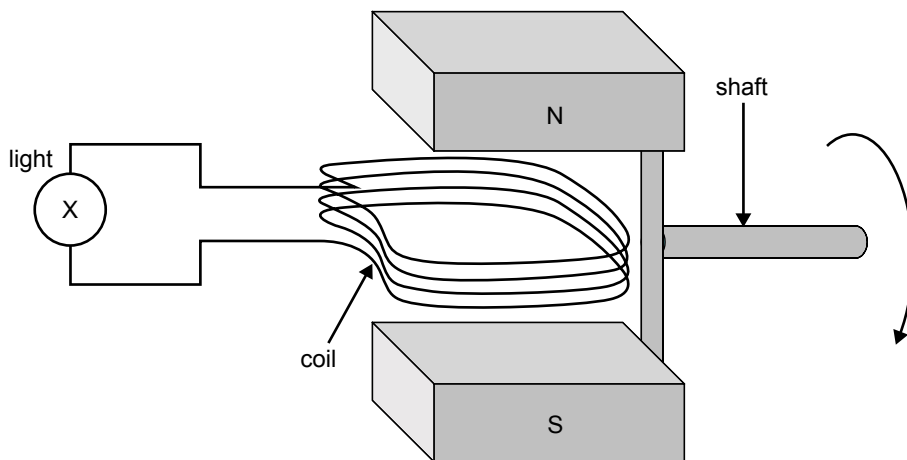

Figure 3

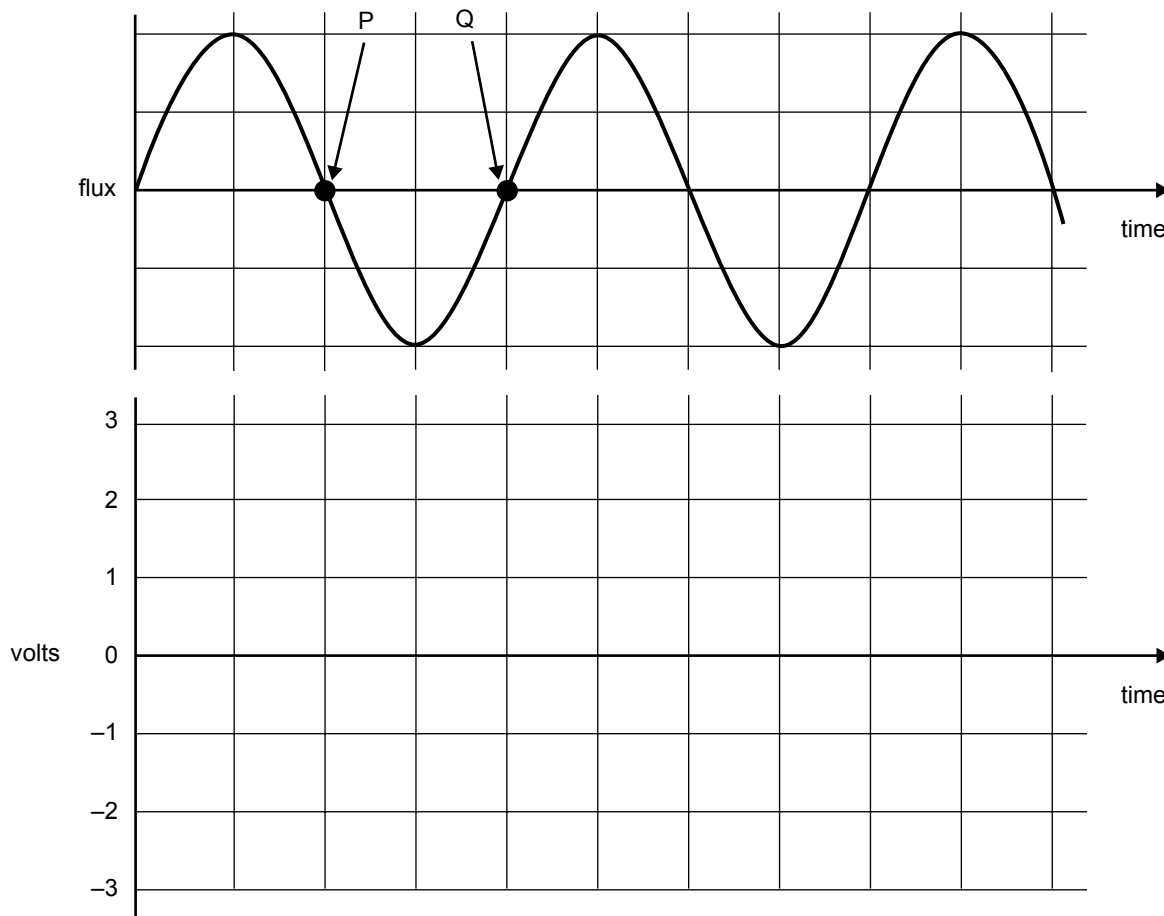

Figure 4

Question 7

What is the time difference between points P and Q in Figure 4?

s

2 marks

Question 8

Complete Figure 4 by sketching the voltage output of the coil. Label your sketch to indicate the maximum and minimum voltages.

4 marks

Question 9

The electric motor is now turned off, and the shaft gradually slows to a halt.

Which one of the following diagrams best describes the voltage output of the generator as it comes to rest?

A.

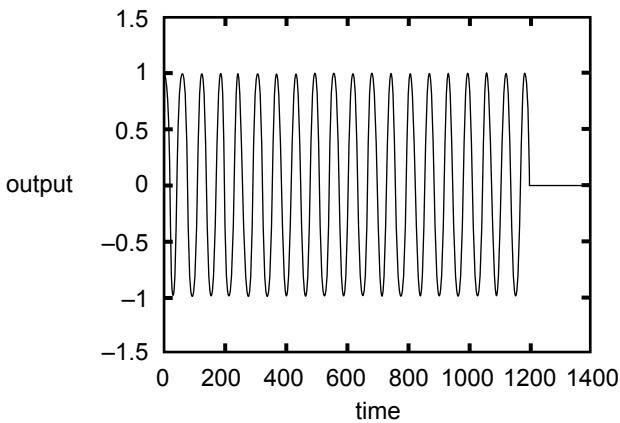

B.

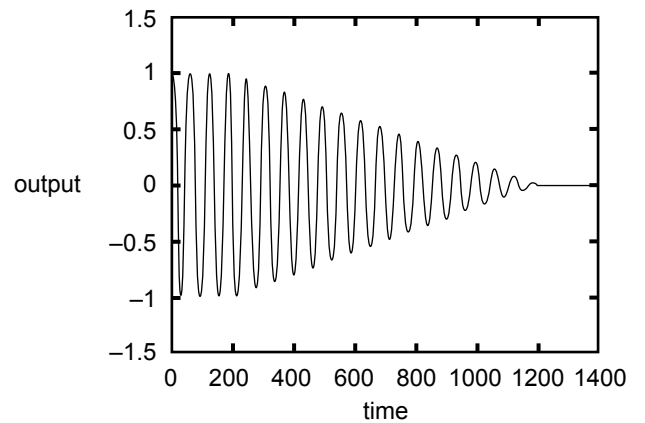

C.

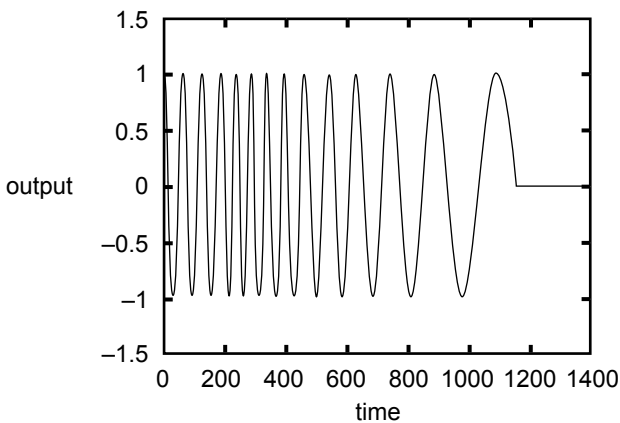

D.

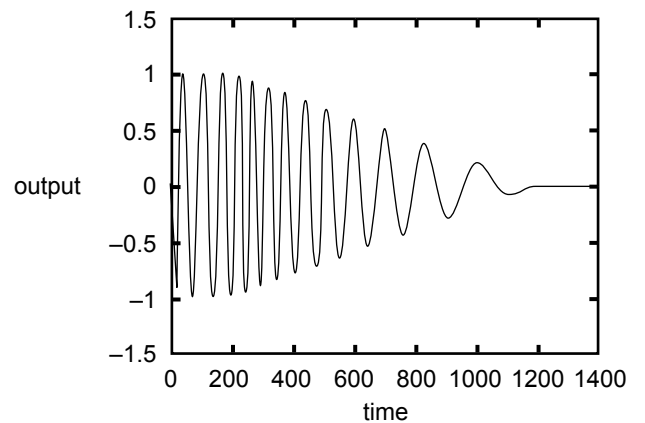

2 marks

Question 10

Which **one or more** of the following actions would increase the emf of this generator to $4.0 V_{\text{RMS}}$?

- A. increase the number of turns to 80
- B. increase the thickness of the wire used
- C. decrease the number of turns to 20
- D. decrease the thickness of the wire used

2 marks

Question 11

Briefly describe the function performed by the commutator in a DC generator.

2 marks

John is using a small portable generator which has both a $240 \text{ V}_{\text{RMS}}$ and $12 \text{ V}_{\text{RMS}}$ output. He wants to power two identical 12 V lamps as shown in Figure 5. The first lamp is connected directly to the low voltage output of the generator. The second lamp is some distance away and requires a 75 m extension lead. The total resistance of the extension lead is 1.0Ω . When the generator is started, both lamps glow, but lamp 1 is considerably brighter than lamp 2. John measures the current at R to be 4.0 A . Assume both lamps have constant resistance and obey Ohm's law.

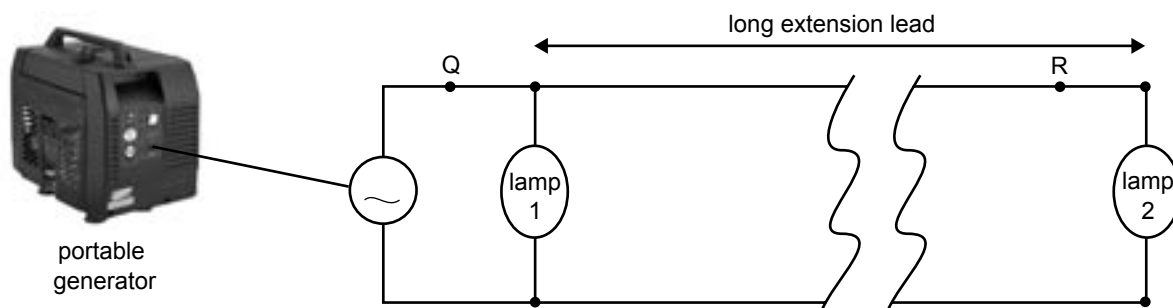

Figure 5

Question 12

Why is lamp 1 brighter than lamp 2? Justify your answer.

3 marks

Question 13

Calculate the power dissipated in lamp 2.

W

4 marks

Question 14

Which one of the following statements is true?

- A. the current at Q is less than 4 A
- B. the current at Q is 4 A
- C. the current at Q is 8 A
- D. the current at Q is greater than 8 A

2 marks

John plans to use the $240 \text{ V}_{\text{RMS}}$ output of the generator to supply lamp 2 with $12 \text{ V}_{\text{RMS}}$.

Question 15

Complete Figure 6 below by designing a step-down transformer to deliver $12 \text{ V}_{\text{RMS}}$ to lamp 2. Make sure that you clearly label the diagram.

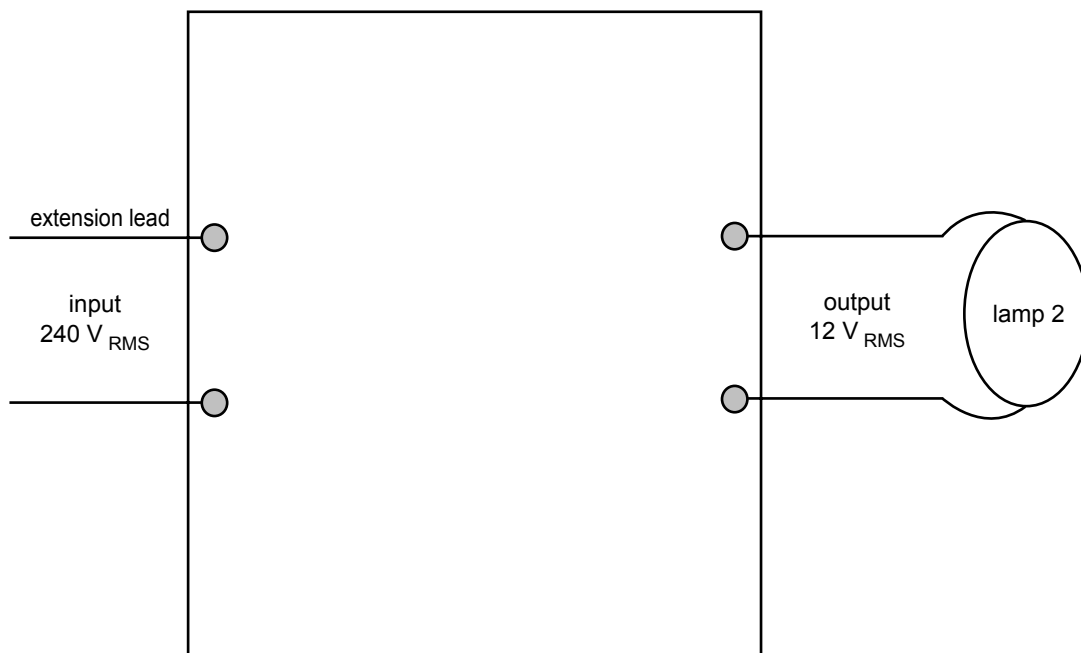

Figure 6

4 marks

Question 16

For lamp 2 it is preferable to use the $240 \text{ V}_{\text{RMS}}$ and then step it down to $12 \text{ V}_{\text{RMS}}$ rather than using the $12 \text{ V}_{\text{RMS}}$ output. Explain the reason for this.

2 marks

SECTION B – Detailed studies

Instructions for Section B

Choose **one** of the following **Detailed studies**. Answer **all** the questions on the Detailed study you have chosen.

Detailed study 1 – Synchrotron and applications

A monochromatic beam of x-rays, wavelength of 71 pm is scattered from a block of carbon as shown in Figure 1. Detectors have been placed at three positions marked A, B and C.

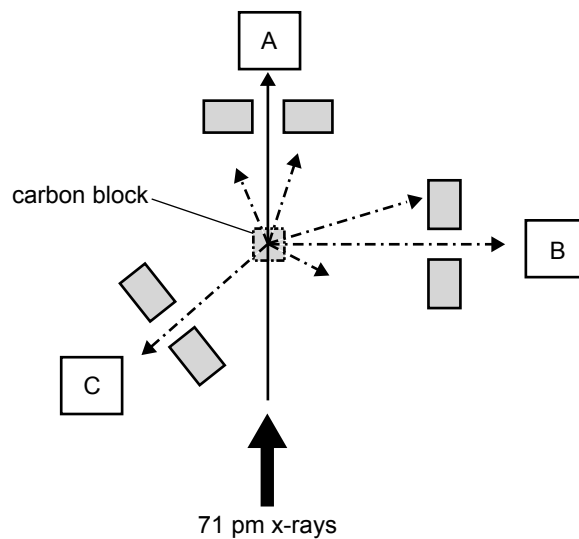

Figure 1

At each of these positions, the spectrum of x-rays has been measured. The results are shown below. The measurement at position A (0°) shows a clear peak at 71 pm, as expected. However, at B (90°) and C (135°) two distinct peaks are evident.

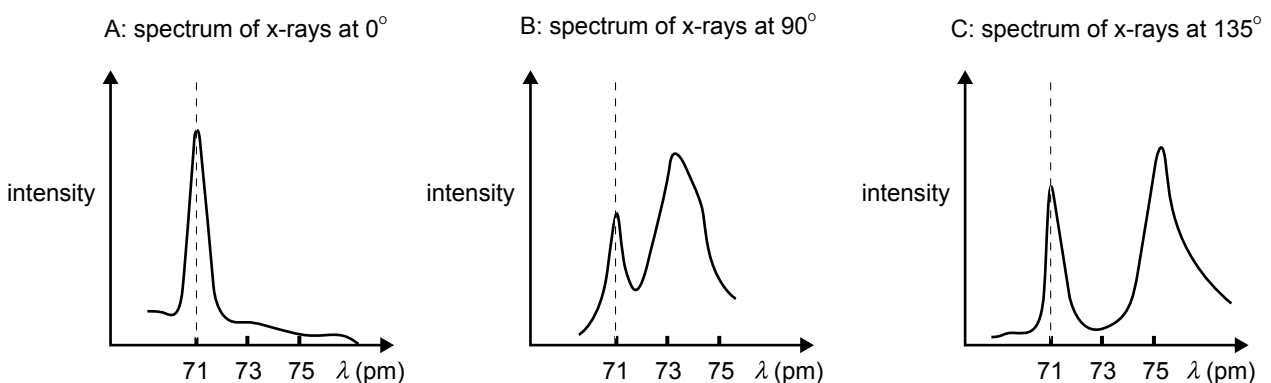

Figure 2

Question 1

Which one of the following best describes the process which produces the higher peak at approximately 73 pm in the 90° measurement?

- A. Thomson Scattering
- B. Compton Scattering
- C. photoelectric effect
- D. none of the above

2 marks

Question 2

Estimate the wavelength of Thomson scattered x-rays in the 135° measurement. Include units in your answer.

2 marks

Question 3

Identify **two** beneficial characteristics of the radiation produced by a synchrotron and explain why these characteristics are beneficial.

Characteristic 1

Characteristic 2

4 marks

Question 4

Each stage of a LINAC boosts the energy of an electron beam by the same amount.

However, the physical length of the accelerating stages are different. Why is this the case?

2 marks

A beam of 10 keV electrons enters a uniform magnetic field of strength 2.0T as shown in Figure 3.

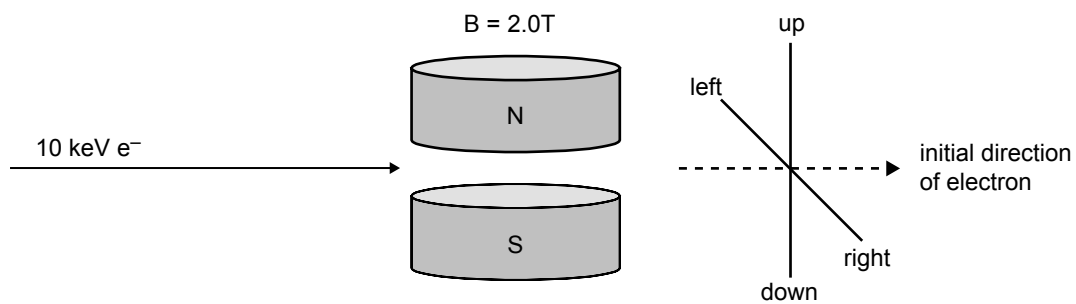
**Figure 3****Question 5**

Which one of the following best describes the path of an electron as it passes through the magnetic field above?

- A. the electron is deflected to the left
- B. the electron is deflected to the right
- C. the electron is deflected up
- D. the electron is deflected down

2 marks

Question 6

Show that the velocity for 10 keV electrons is approximately $6 \times 10^7 \text{ m s}^{-1}$.

$$(m_e = 9.1 \times 10^{-31} \text{ kg})$$

3 marks

Question 7

Determine the radius of curvature of 10 keV electrons as they travel through a magnetic field of 2.0T.

m

3 marks

A beam of x-rays, initially in phase, is scattered by a crystal orientated as shown in the diagram below. Two individual rays of the beam X_1 and X_2 are shown. Ray X_1 reflects on the surface of the crystal. Ray X_2 proceeds into the crystal and reflects on one of the crystal planes at a distance d below the surface.

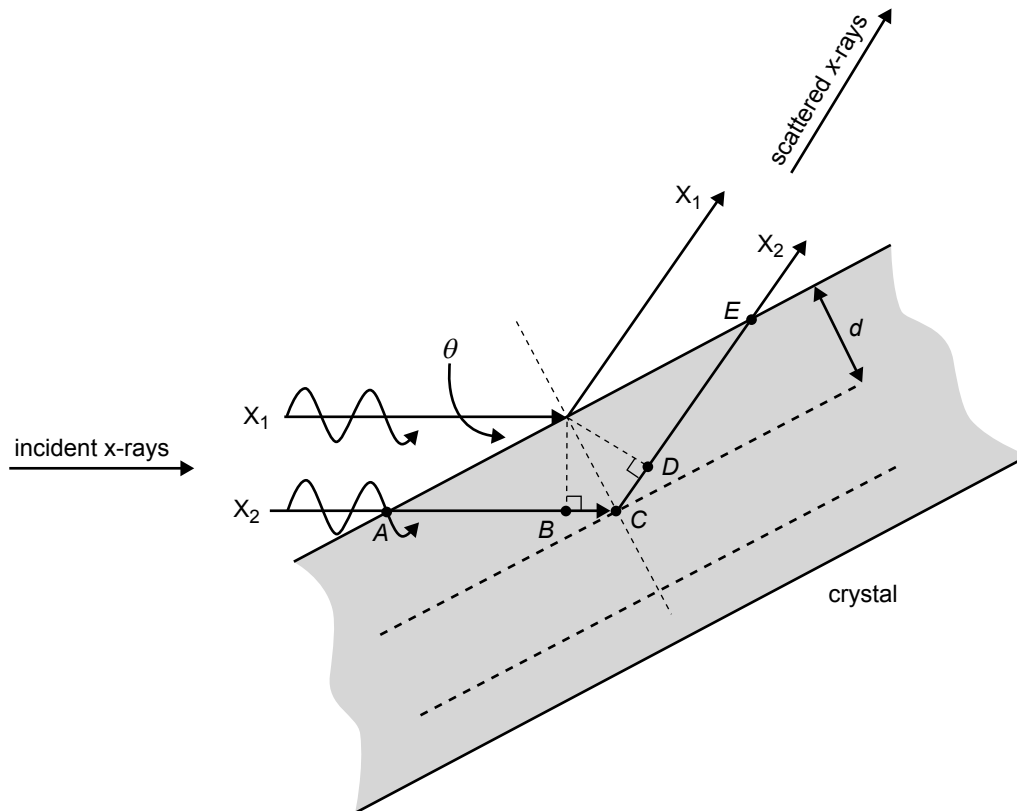

Figure 4

Question 8

Which one of the following line segments best represents the path difference of the scattered x-rays?

- A. $\overline{AC} + \overline{CE}$
- B. \overline{AC}
- C. $\overline{BC} + \overline{CD}$
- D. \overline{BC}

2 marks

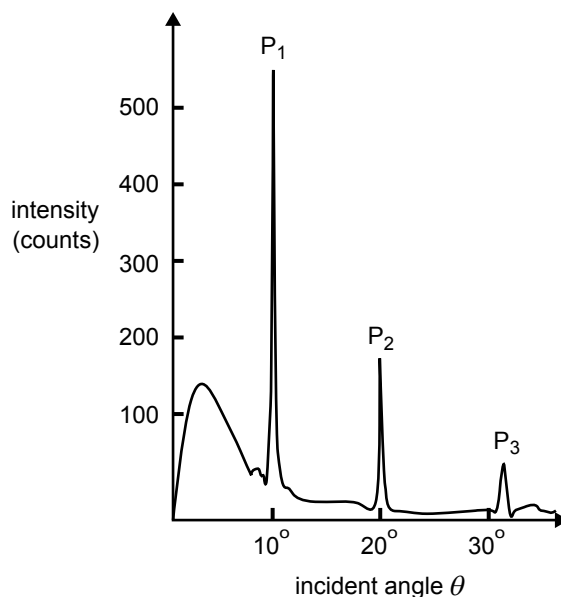

Figure 5

Measurements of the intensity of the scattered beam were made at varying incident angles and the data obtained is shown in Figure 5. The spacing between crystal planes is $d = 0.2 \text{ nm}$.

Question 9

Calculate the wavelength of the incident x-rays.

m

3 marks

Question 10

The wavelength of the incident x-rays is increased slightly ($\sim 10\%$).

Which one of the following best describes what might happen to the peak P_1 in Figure 5?

- A. The incident angle at which P_1 occurs increases.
- B. The incident angle at which P_1 occurs decreases.
- C. The peak P_1 disappears.
- D. The peak remains unchanged.

2 marks

Detailed study 2 – Photonics

Visible light is typically in the range 400–700 nm. Shown in Figure 1 below are the individual wavelength properties of three different light sources. The dashed-vertical lines indicate the range of visible wavelengths.

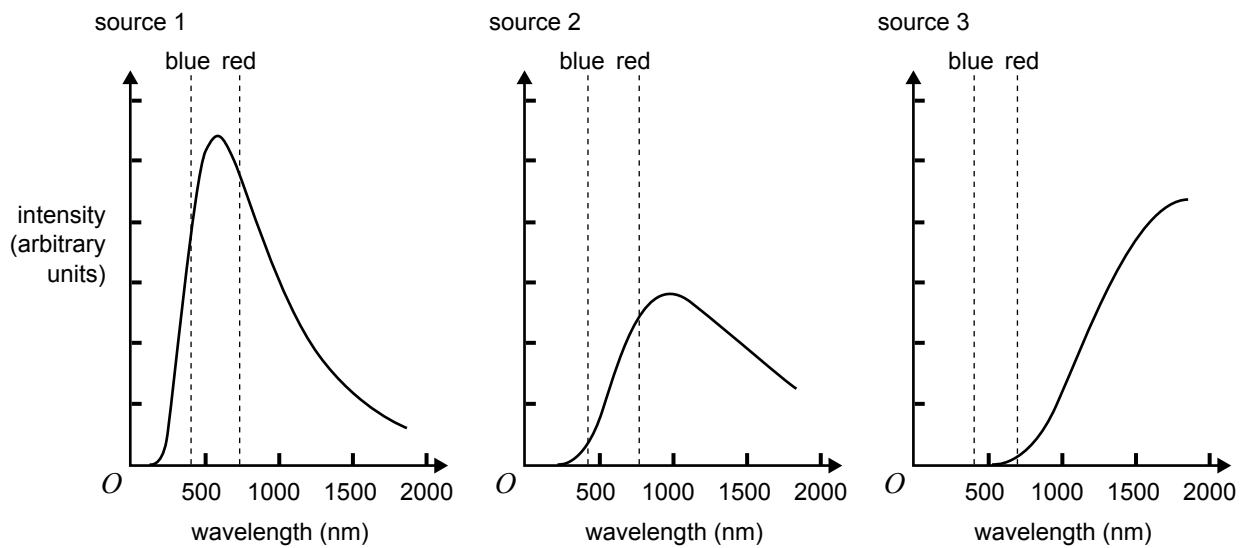

Figure 1

Question 1

Identify each source of light from the six options below, and write your choice clearly in the boxes.

- candle
- 100 W incandescent globe
- laser
- LED (Light Emitting Diode)
- mercury vapour lamp
- sunlight

source 1

source 2

source 3

3 marks

Question 2

Describe how light is produced in a laser. Include in your description a concise term for the type of light that is produced by a laser.

3 marks

The light output of an LED of band gap energy 1.9 eV is being investigated with a variable DC power supply. The power supply voltage is slowly increased and once the potential across the LED reaches 1.9 V, a current of 5 mA flows, and the LED begins to glow.

Question 3

Calculate the wavelength of the light emitted by this LED.

m

3 marks

Question 4

The power supply voltage applied is now increased slightly. Which **one or more** of the following statements is/are **true**?

- A. The wavelength of the light emitted increases.
- B. The wavelength of the light emitted decreases.
- C. The wavelength of the light emitted remains the same.
- D. The current flow through the LED increases.
- E. The current flow through the LED decreases.
- F. The current flow through the LED remains the same.

--

2 marks

Question 5

Students are performing an experiment to investigate the transmission of light in a long plastic cable, 3 mm in diameter. Initially, the cable transmitted about 30% of the input light to the output. When the cable was partially immersed in a fluid as shown in Figure 2, the output changed dramatically. Note that the refractive index of the fluid is greater than that of the plastic.

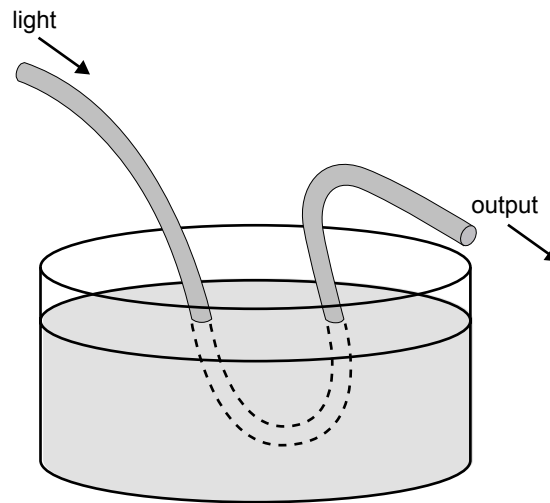
**Figure 2**

- a. Does the output **increase** or **decrease** when the plastic is immersed into the fluid?

1 mark

- b. Explain the reasoning behind your answer.

2 marks

A beam of light from a laser is directed onto the core of a fibre optic cable at various angles. This is shown in Figure 3. The refractive index of the core is slightly greater than the refractive index of the cladding. At incident angles α and β , the beam propagates along the core, whereas at angle γ , the beam enters the cladding as shown.

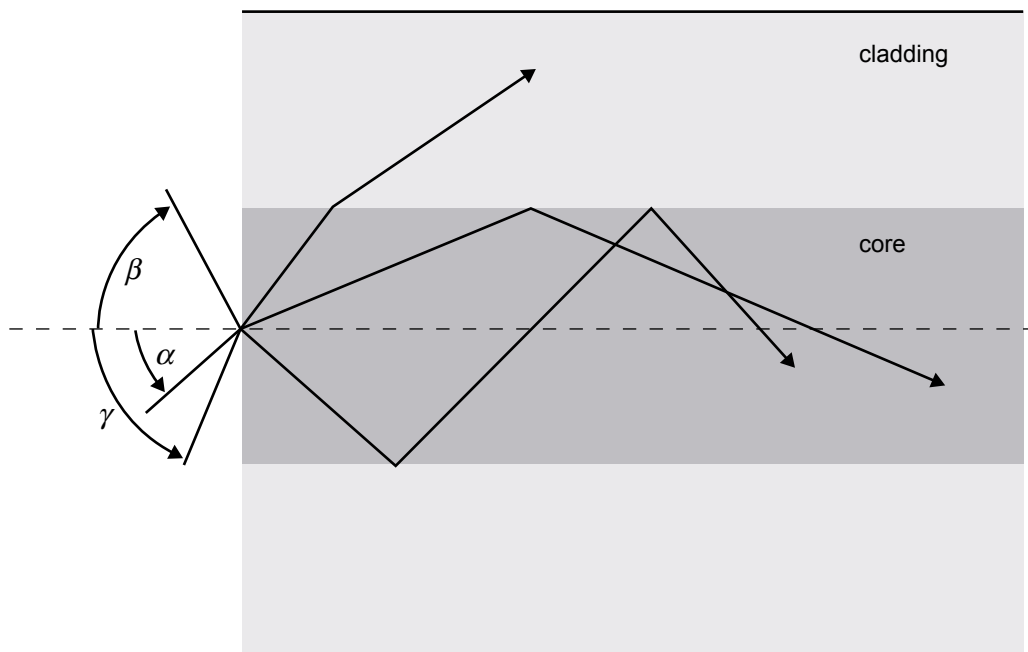

Figure 3

Question 6

Which one of the following constraints best defines an approximation for the acceptance θ_A angle of this fibre optic cable?

- A. $\theta_A < \alpha$
- B. $\alpha < \theta_A < \beta$
- C. $\beta < \theta_A < \gamma$
- D. $\theta_A > \gamma$

2 marks

A high-speed communication system will be built linking Melbourne and Broome. The transmission characteristics of the fibre optic cable are shown in Figure 4.

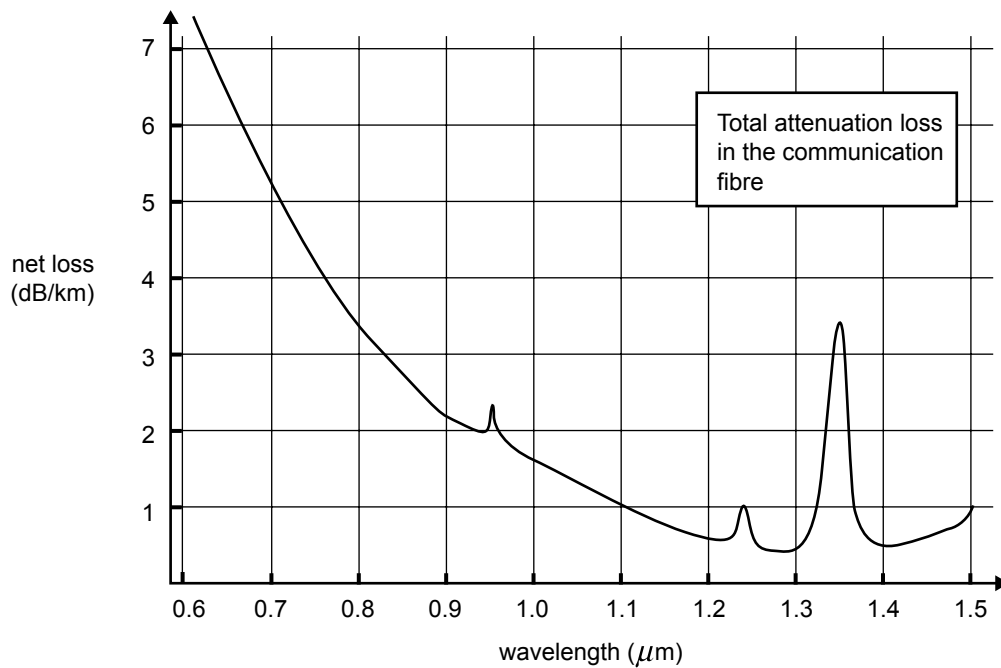

Figure 4

Question 7

What are the merits of using **single-mode** rather than **multi-mode** fibre for this long-distance application?

2 marks

Question 8

Light of wavelength $1.1 \mu\text{m}$ is to be used.

If the maximum signal loss is to be kept less than 30 dB, which one of the following best describes the maximum distance between repeater stations?

- A. 3 km
- B. 10 km
- C. 30 km
- D. 100 km

2 marks

Some enterprising students have decided to make a short film about ants. The intention is to film the ants underground. However, the camera will not fit down into the nest. To overcome this problem, the students plan to borrow an endoscope from a local hospital. This endoscope consists of a focusing lens and a fibre optic imaging bundle surrounded by 9 flexible plastic cables. The outer cables are used to illuminate the object. According to the specifications, the fibre bundle delivers an image of resolution 100 by 100 pixels. The proposed arrangement is shown in Figure 5a and an expanded view of the endoscope is shown in Figure 5b.

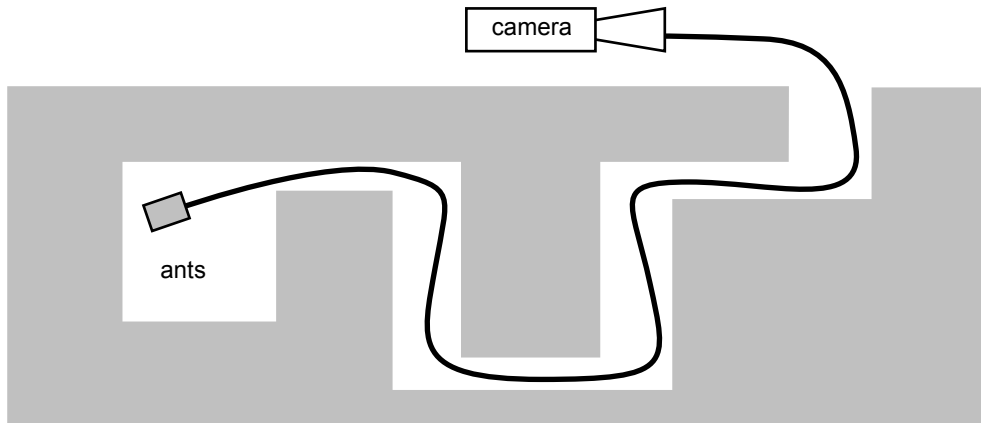

Figure 5a

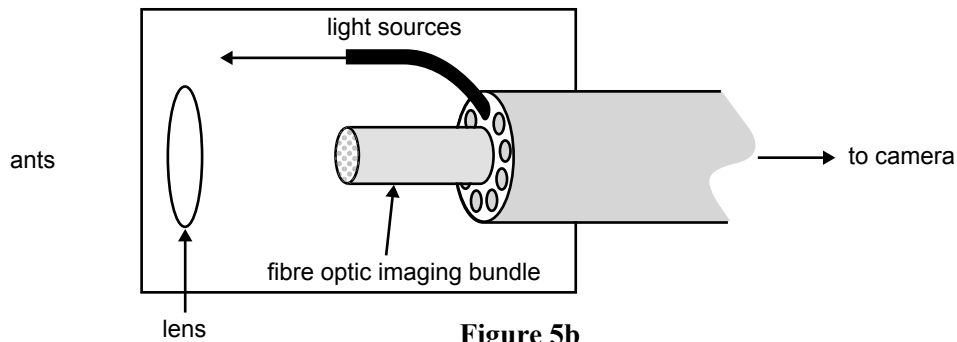

Figure 5b

Question 9

Explain how the imaging bundle works and allows the image of the ants to be viewed by the camera.

3 marks

Question 10

Which one of the following is the best estimate for the number of fibres in the central bundle?

- A. 1
- B. 100
- C. 200
- D. 10 000

2 marks

Detailed study 3 – Recording and reproducing sound

Throughout the questions on sound, take the speed of sound in air to be 340 m s^{-1} .

Question 1

Complete Table 1 by writing the type of microphone which best matches the description in the spaces provided.

Choices – crystal, dynamic, electret-condensor, velocity

Table 1

Microphone type	Description
	The sound pressure moves the cone which is attached to a coil of wire. This coil moves in the field of a magnet and produces a voltage.
	The sound pressure moves the metallic strip in the magnetic field, generating a voltage between the ends of the strip.
	The sound pressure changes the spacing between a thin metallic membrane and the stationary back plate. This causes a change in capacitance and produces a current.

3 marks

Peter is recording a band rehearsal in the school hall. During one of the loud songs played by the band Peter goes to the centre of the hall to measure the sound intensity. He measures a sound intensity level of 120 dB at this location.

Question 2

Which one of the following best describes the maximum sound intensity at this location?

- A. $1 \times 10^{-12} \text{ W m}^{-2}$
- B. 1 W m^{-2}
- C. 10 W m^{-2}
- D. 120 W m^{-2}

2 marks

Peter is concerned that 120 dB is too loud for the parents. The band agrees to try and play with half the sound intensity.

Question 3

Which one of the following best describes the anticipated maximum sound intensity level under these conditions?

- A. 119.5 dB
- B. 117 dB
- C. 114 dB
- D. 60 dB

2 marks

The frequency response of four different speaker systems is being investigated. Shown in Figure 1 are the individual frequency response curves of each speaker system. A test CD is used to compare the performance of each system.

- Track 1 is a series of tones between 100 Hz and 1 000 Hz.
- Track 2 is musical recording of several instruments and sounds in the frequency range 500–10 000 Hz.

In answering the following, you may assume that the CD player and amplifier shown in Figure 2 do not distort the sounds.

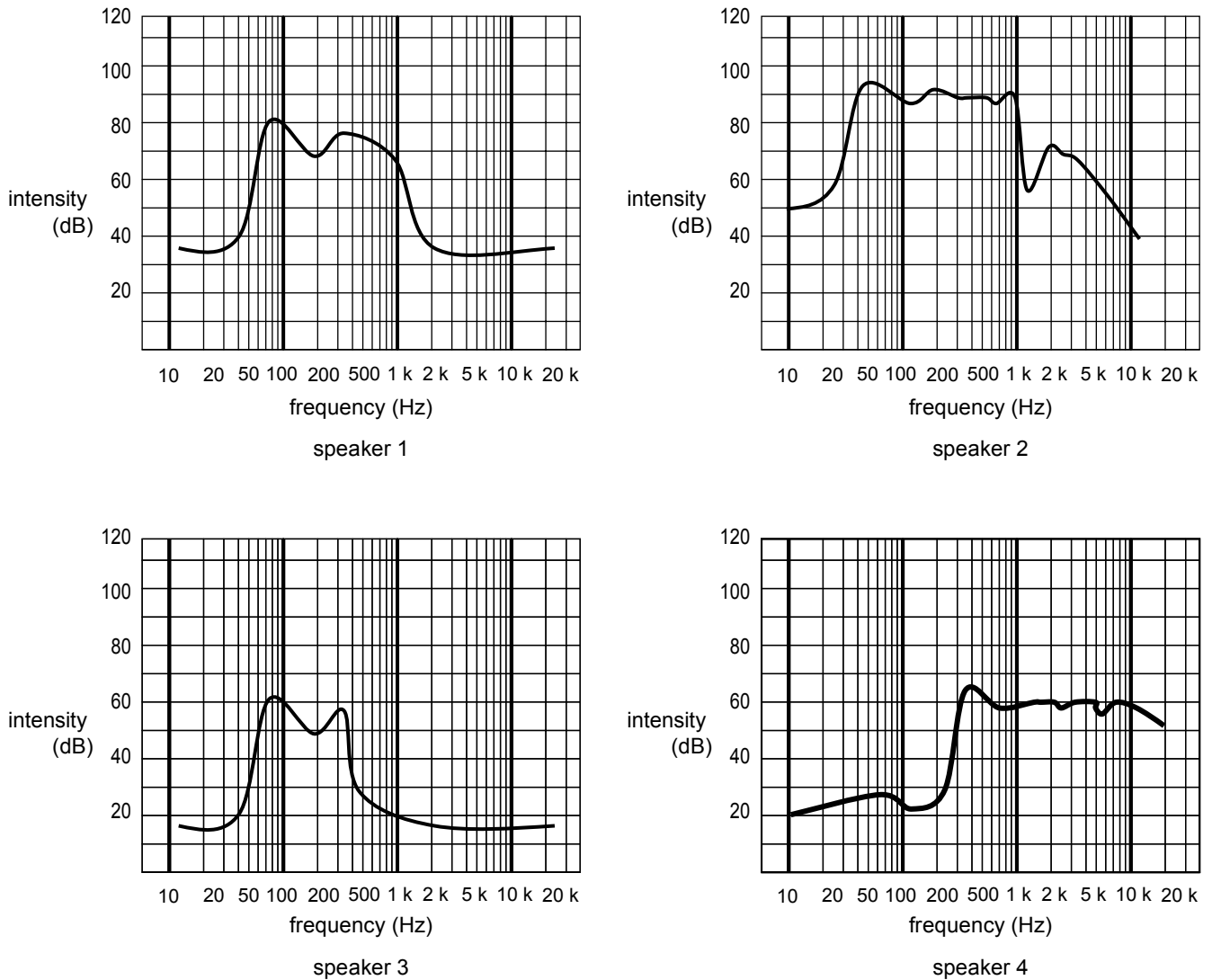

Figure 1

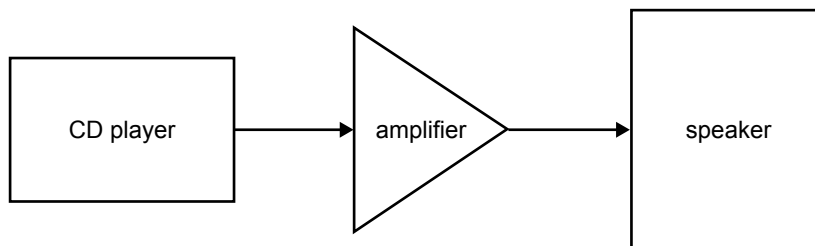

Figure 2

Question 4

Which speaker system could produce the loudest sound for CD Track 1?

- A. speaker 1
- B. speaker 2
- C. speaker 3
- D. speaker 4

2 marks

Question 5

Which speaker system could reproduce CD Track 2 with the best fidelity?

- A. speaker 1
- B. speaker 2
- C. speaker 3
- D. speaker 4

2 marks

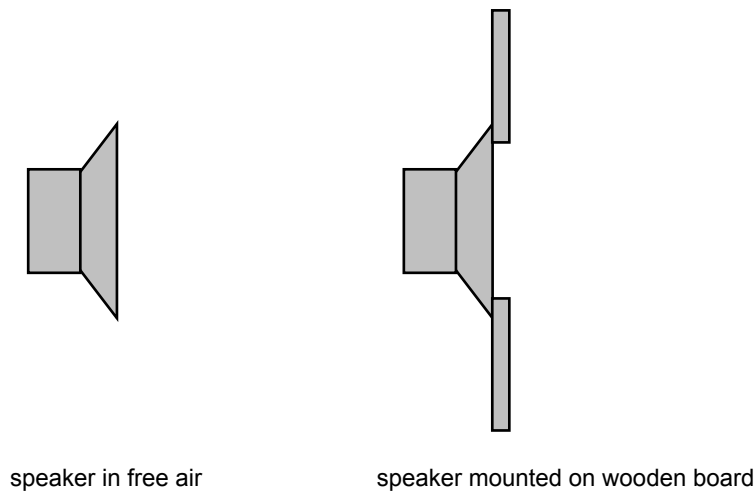

Figure 3

Question 6

A test of each speaker is performed. In each case, the volume of sound produced by the speaker increased when the speaker was mounted on a wooden board as shown in Figure 3 above. Why does this increase occur?

2 marks

Question 7

The combination of multiple speakers in an enclosure can be used to optimise the overall frequency response of a system. Identify the best **two** of the speakers (1–4), in Figure 1 page 33, for inclusion in an infinite baffle enclosure. Explain the reasoning behind your choice.

Choice 1

Choice 2

4 marks

The didgeridoo is a resonant cavity. It can be modelled as a tube of length L , open at one end and closed at the other, as shown in Figure 4. The fundamental frequency of this particular tube is 80 Hz.

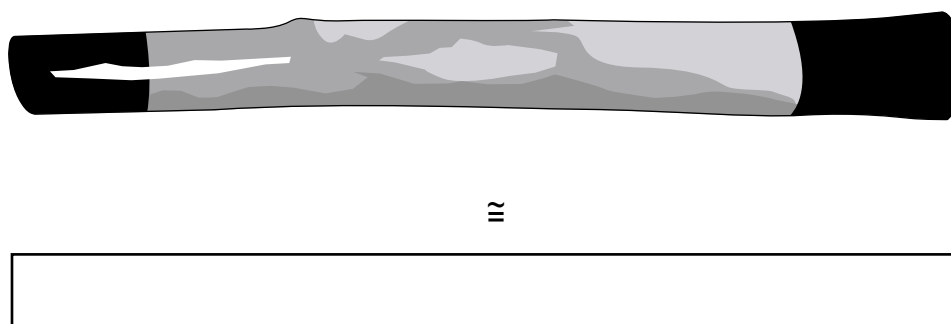
**Figure 4****Question 8**

Estimate the length of this tube, given the speed of sound in air is 340 m s^{-1} and a fundamental resonance of 80 Hz.

 m

2 marks

Question 9

At which **one or more** of the frequencies could the tube resonate?

- A. 20
- B. 210
- C. 320
- D. 560
- E. 800

2 marks

Jane and Jill have recently purchased a surround sound system for their plasma TV. They have installed the small satellite speakers (ss) as shown in Figure 5. The instructions state that the central speaker reproduces most of the dialogue (300–3000 Hz) and the sub-woofer reproduces the low-frequency sounds below 100 Hz.

Initially the central speaker is placed behind the TV screen. Jane and Jill are in the middle of the room as shown.

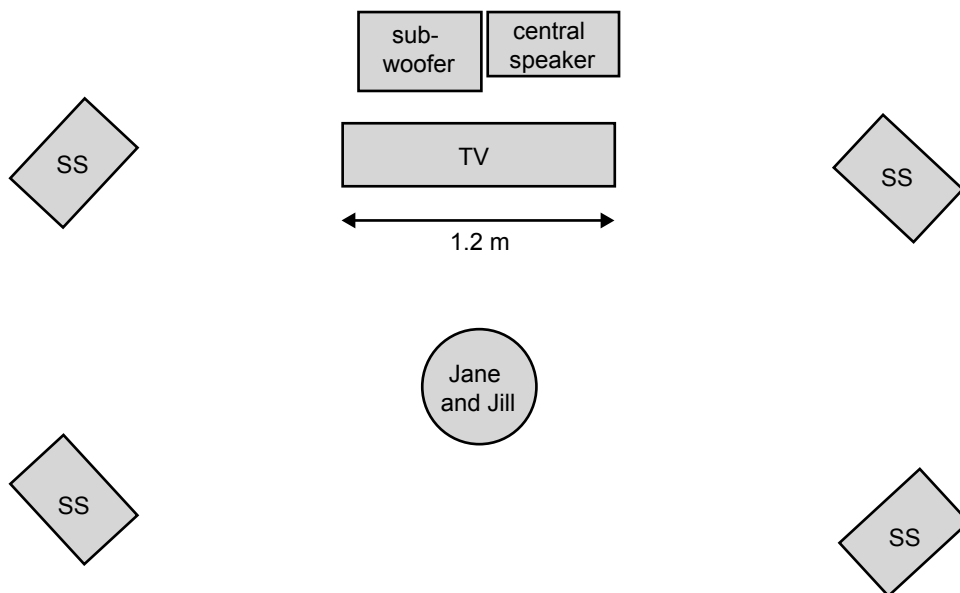

Figure 5

With the central speaker and sub-woofer behind the screen, the dialogue sounds muffled, lacking definition in the high frequencies, yet the low-frequency sounds can be heard quite clearly. When Jane repositions the central speaker underneath the screen, all frequencies can be heard clearly.

Question 10

- a. Calculate the wavelength of a 100 Hz sound in air.

2 marks

- b. Explain why the high-frequency sounds cannot be heard clearly when the central speaker is behind the screen, although the low-frequency sounds from the sub-woofer can be heard.

2 marks