

**Core**

This section is compulsory.

**Question 1**

A persons body fat percentage is the weight of their body fat expressed as a percentage of their total body weight.

The body fat percentage (BFP) of a sample of 15 teenage boys is given below.

%

9	15	16	23	16	10	24		
16	15	21	12	17	13	17	19	

Teenage boys with a BFP of 9% - 15% (inclusive) are considered healthy.

- a. What is the percentage of teenage boys in this sample who are considered healthy?

---

---

1 mark

- b. For this set of data, what is the

i. mode

---

ii. mean

---

1 + 1 = 2 marks

The standard deviation of the BFP for this sample is 4.3 (to 1 decimal place).  
One of the boys in the sample has a BFP of 19.

- c. Calculate the standardized BFP ( $z$  score) of this boy relative to the sample. Express your answer correct to one decimal place.

---

---

1 mark

**Question 2**

The stemplot below shows the body fat percentage (BFP) for a sample of teenage girls.

0	9						
1	2	3	3	4	4	4	4
1	6	7	7	8			
2	0	0	1				
2	6						
3	1						
3							
4	0						

- a. What is the median?

---

1 mark

- b. Give two reasons why the median is a better measure of the centre of this distribution than the mean.

---



---



---

2 marks

**Question 3**

The body fat percentage (BFP) was calculated for a sample of 52 women and 43 men. These men and women were then classified as having an acceptable or unacceptable BFP. A total of 12 women and 19 men in this sample were found to have an unacceptable (BFP).

- a. Complete the two-way frequency table below using this information.

	Gender	
BFP	female	male
acceptable		
unacceptable		
total		

2 marks

The researchers conducting this investigation had an hypothesis that body fat percentage is related to gender.

- b. State whether or not the data in the two-way frequency table in part a. supports this hypothesis. Give appropriate percentages to support your answer.

---



---



---



---



---

2 marks

#### Question 4

The age in years and the body fat percentage (BFP) for a group of women is given in the table below.

Age (years)	Body fat percentage (%)
21	18
59	23
32	20
59	22
37	22
44	23
48	22
53	23
60	27
63	40
62	28
61	32
64	42

The results are displayed on the scatterplot below.

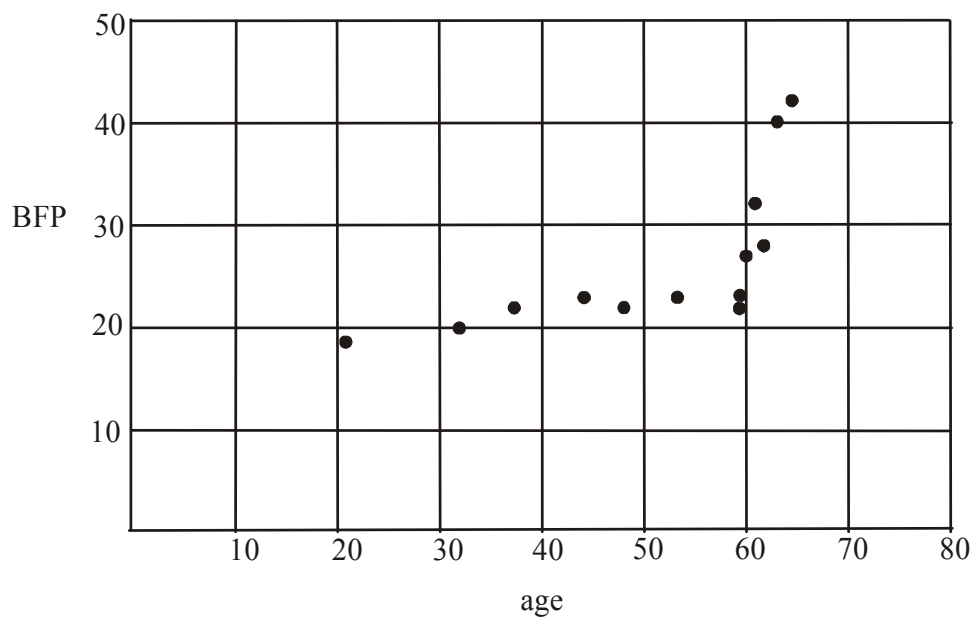

- a. Explain why it is not appropriate to determine an equation for a least squares regression line for the variables age and BFP.

---

---

---

1 mark

A transformation is to be applied to the data so that a least squares regression line can be fitted.

The variable “BFP” is to be replaced with the variable “ $\log(\text{BFP})$ ”.

- b. What other type of transformation could have been used?

---

---

1 mark

- c. Find the equation of the least squares regression line linking the variables “age” and “ $\log(\text{BFP})$ ”. Express coefficients correct to 4 decimal places.

---

---

2 marks

Total 15 marks

## Module 2: Geometry and trigonometry

If you choose this module all questions must be answered.

### Question 1

A reinforced concrete base is constructed on sloping land. The base is a right triangular prism as shown in the diagram below.

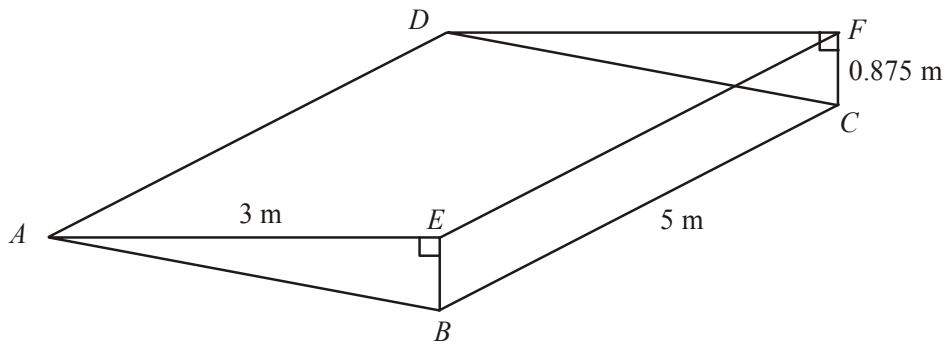

The rectangle  $ABCD$  is in contact with the ground and the rectangle  $AEFD$  is a horizontal surface.

The distance  $AE$  is 3m,  $BC$  is 5m and  $CF$  is 0.875m.

- a. Show that the length of  $AB$  is 3.125m.

---



---



---

1 mark

- b. Find the angle  $BAE$ . Express your answer in degrees correct to 1 decimal place.

---



---



---

1 mark

A piece of reinforcing steel runs from point  $A$  to  $C$ .

- c. Find the length of this piece of steel. Express your answer in metres correct to 4 decimal places.

---



---



---

1 mark

- d. Find the angle  $CAF$ . Express your answer in degrees correct to 2 decimal places.

---



---



---

1 mark

### Question 2

One of the items to sit on the base is a water tank.

The tank is a prism with a cross-sectional area made up of a rectangle with a semi-circle at each end.

The tank is shown below.

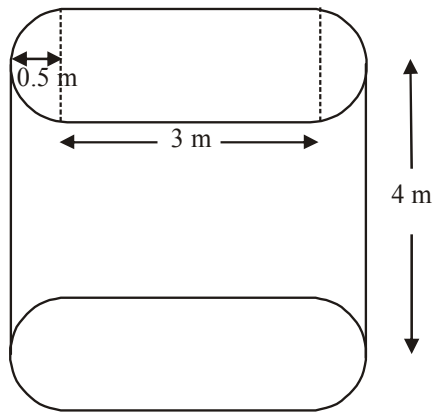

The height of the water tank is 4m and the length is 4m. The radius of each semi-circular cross-section is 0.5m and the length of the rectangular cross-section is 3m as indicated in the diagram.

- a. Find the surface area of the top of the tank. Express your answer in square metres correct to 4 decimal places.

---

1 mark

- b.** What is the volume of the tank? Express your answer in cubic metres correct to 2 decimal places.

---

---

1 mark

- c.** One cubic metre can hold 1000 litres of water. Use your answer to part **b.** to find out how many litres of water this tank can hold.

---

---

1 mark

- d.** Find the total surface area (including the base) of the outside of the water tank. Express your answer in square metres correct to 2 decimal places.

---

---

---

---

---

2 marks

**Question 3**

Water enters the tank from a pipe at the edge of an eave of a nearby building. The pipe  $AC$ , together with the tank and the building are shown in the diagram below.

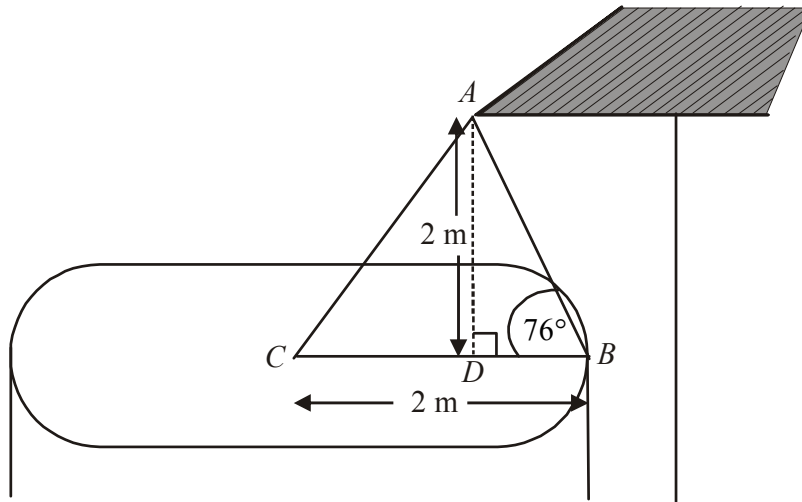

The top of the tank has its centre at  $C$ . The point  $B$  lies on the edge of the tank and the distance  $BC$  is 2 metres. The point  $D$  lies on  $BC$ , 2 metres vertically below  $A$ . The angle,  $ABC$  is  $76^\circ$ .

- a. Find the length  $AB$ . Express your answer in metres correct to 4 decimal places.

---



---



---

1 mark

- b. Use the cosine rule to find the length of the pipe from  $A$  to  $C$ . Express your answer in metres correct to 1 decimal place.

---



---



---

1 mark

- c. Find the angle  $ACB$ . Express your answer correct to the nearest degree.

---



---



---

1 mark



- d. Find the area of triangle  $ABC$  using Heron's formula. Express your answer to the nearest square metre.

---



---



---

1 mark

A straight metal strut of length 2 metres is attached to the tank at  $B$  and to the pipe at  $E$  to give the pipe some extra support. The diagram below shows the metal strut indicated by  $BE$ .

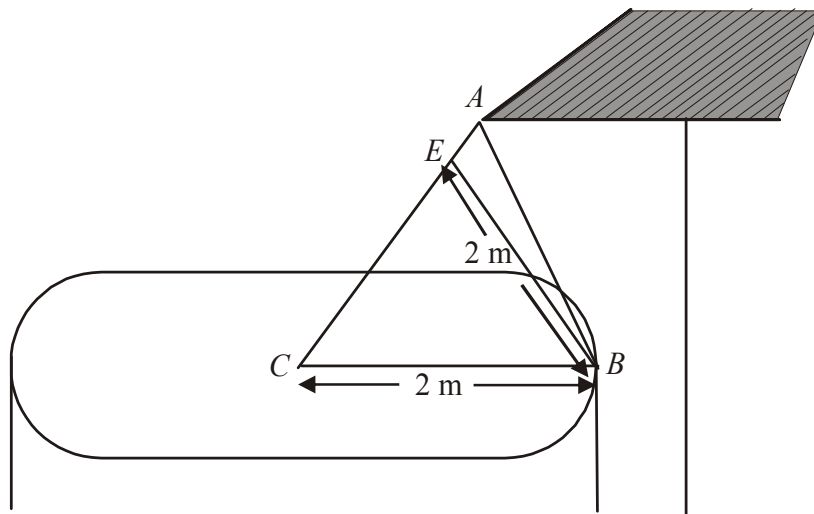

- e. Find the distance  $CE$ . Express your answer in metres correct to one decimal place.

---



---



---



---



---



---



---



---

2 marks  
Total 15 marks

### Module 3: Graphs and relations

If you choose this module all questions must be answered.

#### Question 1

Kate runs a furniture hire business. She hires out furniture to people who are selling their home and wish to improve its look. She offers different combinations of furniture and decorative items.

The costs of one of her most popular combinations for periods up to 40 days are shown on the graph below.

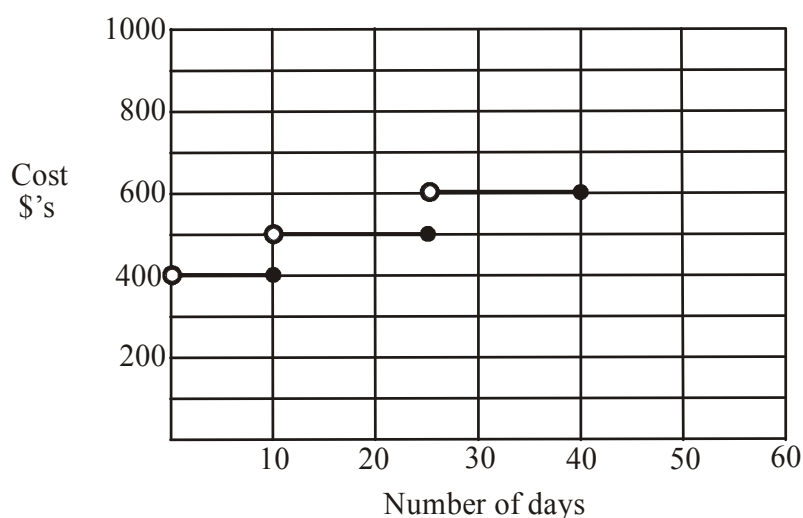

- a. What is the cost of hiring this combination for 20 days?

---

1 mark

The cost of hiring this combination for more than 40 days up to and including 60 days is \$700.

- b. On the graph above, draw this information.

1 mark

Kate has noticed that a very high percentage of furniture is hired for 10, 25 or 40 days.

- c. Explain why people might do this.

---



---

1 mark

**Question 2**

Kate estimates that across her business, in the coming year, the average revenue she will receive per client will be \$1200.

- a. Write an equation that gives the total revenue,  $R$ , in dollars, forecast for the coming year when Kate has  $x$  clients.

---

1 mark

Kate also estimates that in the coming year the cost of running her business will be \$80 000 plus an average of \$400 per client.

- b. Write an equation that gives the total cost,  $C$ , in dollars, of running the business in the coming year in terms of the number of clients  $x$ .

---

1 mark

- c. How many clients will Kate need in the coming year for her business to break even?

---



---



---



---

1 mark

- d. If Kate has 60 clients in the coming year state whether her business makes a profit or a loss and find that profit or loss.

---



---



---



---



---

1 mark

**Question 3**

Kate offers two very popular furniture hiring packages; the luxury package and the standard package.

Let  $x$  be the number of luxury packages Kate hires out in a month.

Let  $y$  be the number of standard packages Kate hires out in a month.

There are constraints on the number of these packages she can hire out in a month due to furniture availability, staff availability and time availability.

The inequalities below define these constraints.

Constraint 1:  $x \geq 0$

Constraint 2:  $y \geq 0$

Constraint 3:  $2x + 5y \leq 75$  (staff availability)

Constraint 4:  $x + y \leq 21$  (time availability)

Constraint 5:  $x \leq 15$  (furniture availability)

- a. Explain whether or not there is any constraint on the amount of furniture available for standard packages.

---



---



---

1 mark

The line  $2x + 5y = 75$  is drawn on the graph below.

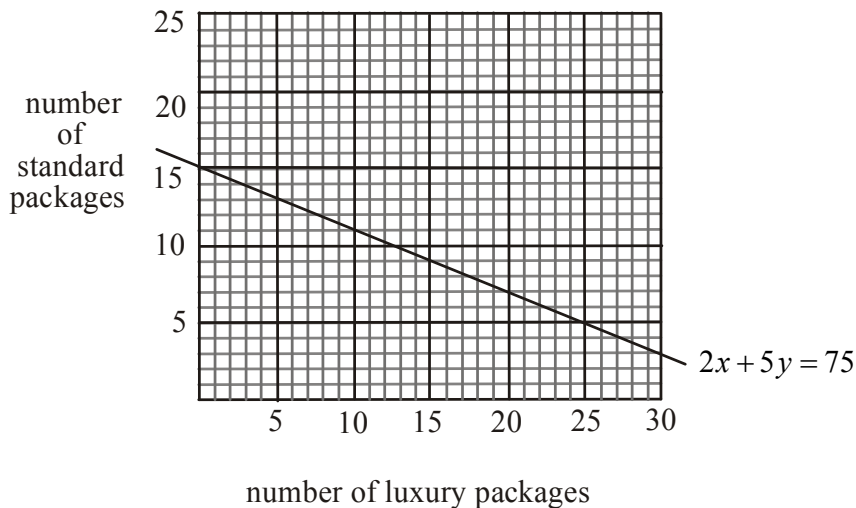

- b. On the graph above, sketch and label the line  $x + y = 21$ .

1 mark

- c. On the graph above, sketch and label the line  $x = 15$ .

1 mark

- d. On the graph above, shade the feasible region described by the five constraints.

1 mark



A profit of \$800 is made on a luxury package and a profit of \$500 is made on a standard package.

- e. Write an objective function for the profit  $P$  in terms of  $x$  and  $y$ .

---



---

1 mark

- f. Find the maximum profit that can be made on these two packages in a month.

---



---



---



---

1 mark

The constraint associated with the furniture availability is changed to  $x \leq 10$ .

- g. Which one of the six constraints originally given now has no effect on the feasible region? Explain your answer.

---



---



---



---

1 mark

- h. What is the maximum profit now possible on these packages for the month?

---



---



---



---

1 mark  
Total 15 marks

### Module 5: Networks and decision mathematics

If you choose this module all questions must be answered.

#### Question 1

A group of six islands  $A - F$ , together with the distances in kilometres between them, are shown on the graph below.

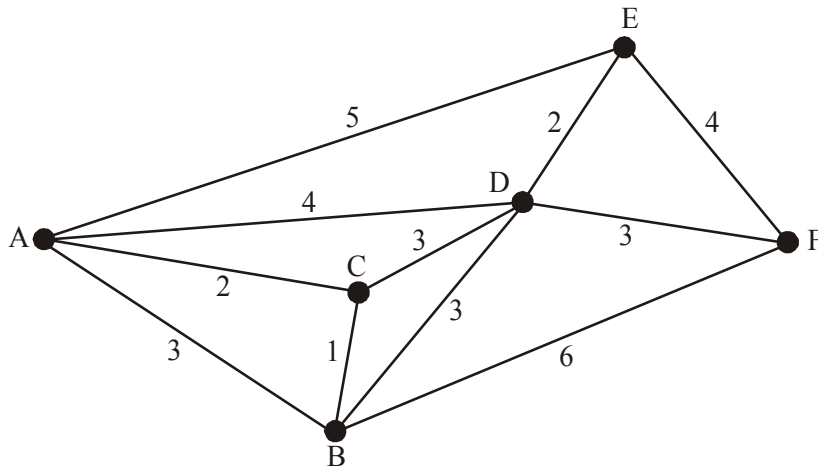

- a. Find the shortest distance from  $A$  to  $F$ .

---

1 mark

- b. Explain why the path  $E A B F E D C$  does not form a tree.

---



---



---

1 mark

- c. i. On the graph below representing the group of islands, draw a minimal spanning tree.

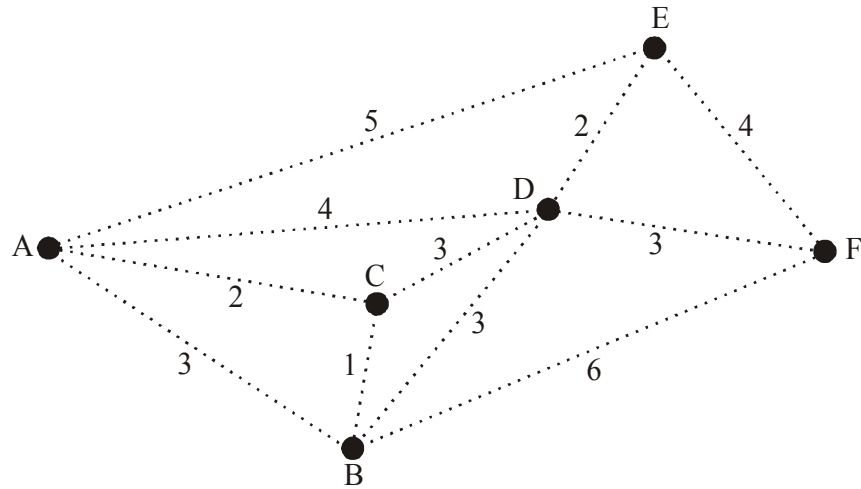

1 mark

- ii. How many different minimal spanning trees exist for this graph?

---

1 mark

- iii. Communication cable is to be laid between the islands. What is the minimum length of cable that has to be laid so that all the islands can be connected?

---

1 mark



**Question 2**

During the week water taxis provide transport for people travelling between the islands. The number of people who can be transported in a day from one island to another in a particular direction is indicated on the edges of the directed graph below.

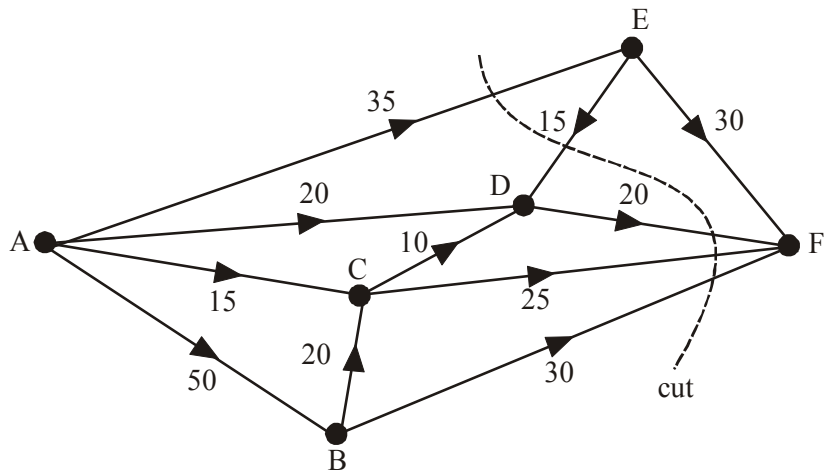

A cut is made through the network.

- a. What is the capacity of this cut?

---

1 mark

- b. What is the maximum number of people who can be transported by water taxi from island *A* to island *F* on a weekday?

---

1 mark

**Question 3**

The directed graph below shows the reachability of the islands by commercial ferries on a Sunday.

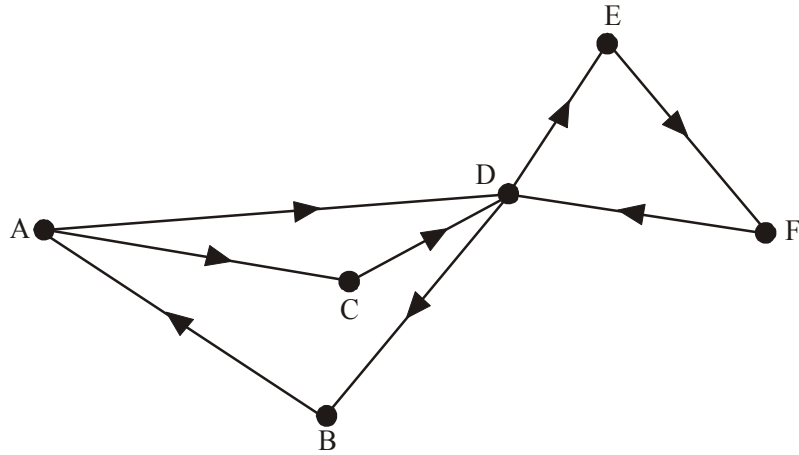

A directed line such as



means that island *D* can be reached from island *A* by commercial ferry on a Sunday.

- a.** Which island is considered most reachable when considering just one-step reachability?

---



---



---

1 mark

- b.** By adding together the one-step and two-step reachability for each island, rank the top three islands in order of reachability.

---



---



---



---



---

2 marks

**Question 4**

An upgrade is being carried out on the wharf on island *E*. There are 9 activities that need to be completed. The directed network below shows these 9 activities, *A – I*, and the time, in days, required to complete each one.

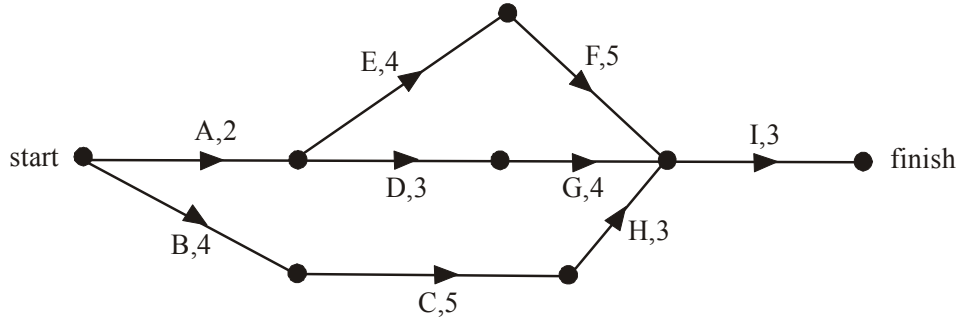

a. What is the shortest time in which these improvements can be completed?

---



---

1 mark

b. Which two activities have the greatest slack time?

---



---

1 mark

c. What is the latest start time for activity *E*?

---

1 mark

Activity *C* is to be reduced by 3 days.

d. Which 3 activities have now become critical to the upgrade being completed in the shortest possible time?

---



---



---

1 mark

- e. Explain whether it was worth reducing activity  $C$  by 3 days given that it cost money each day to do so. Use completion times for the project to justify your opinion.

---

---

---

---

---

1 mark  
Total 15 marks