

**MAV Trial Examination Paper 2010
Further Mathematics Examination 2
SOLUTIONS**

CORE: Data Analysis

Question 1

a.

Travel to school	Frequency
Car	7
Public Transport (tram, train or bus)	12
walk	6
Total	25

[A1]

b. $\frac{7}{25} \times \frac{100}{1} \% = 28\%$

[A1]

Question 2

Yes, the graph does support the opinion that the type of travel is associated with school level. As the school level increases so do the number of students taking public transport. The percentage that travel by transport increase from 10% to 35% to 45% as the school level went from junior to middle to senior school.

OR

Yes, the graph does support the opinion that the type of travel is associated with school level. As the school level increases the number of students travelling by car to school decreases. The percentage that travelled by car decreased from 50% to 40% to 20% as the school level went from junior to middle to senior school.

**Yes with supporting statement [A1]
Percentages quoted to support statement [A1]**

Question 3

a. 26 minutes

[A1]

b. negatively skewed

[A1]

c. 50% of $80 + 50\%$ of $120 = 40 + 60 = 100$

[A1]

d.

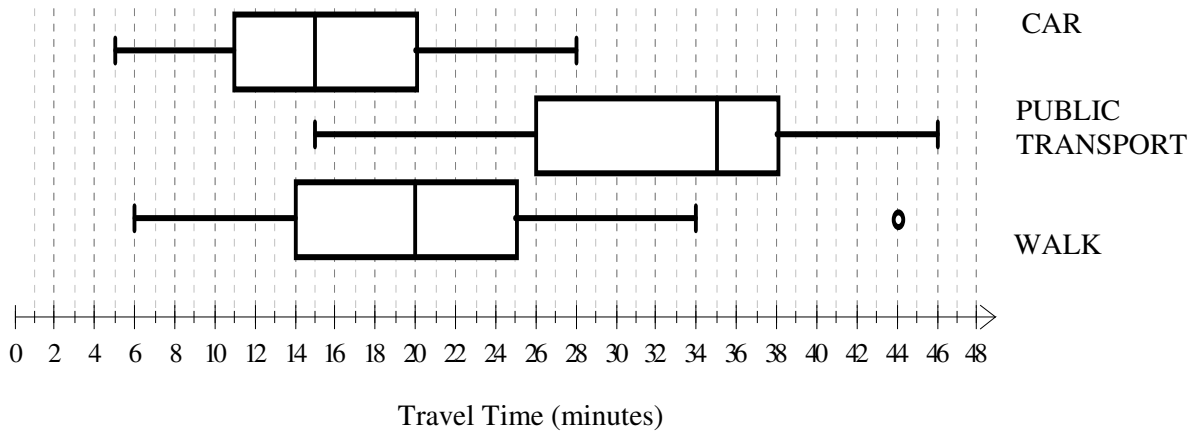

Boxplot shows minimum = 6, $Q_1 = 14$, Median = 20, $Q_3 = 25$, Maximum = 44

[A1]

Boxplot includes outlier at 44 and whisker end at 34

[A1]

e.

$$\begin{aligned} \text{The upper boundary} &= Q_3 + 1.5 \times IQR \\ &= 25 + 1.5 \times 11 \\ &= 25 + 16.5 \\ &= 41.5 \end{aligned}$$

35 minutes would not be regarded as an outlier because it falls below the upper boundary of 41.5 minutes.

[A1]

Question 4

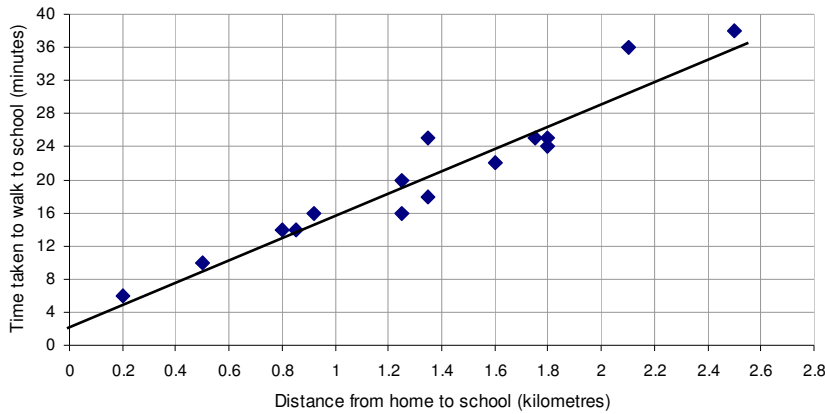

a. Line passes through at least two of (0, 2.5) (1, 16) and (2, 29.5)

[A1]

b. For every one kilometre increase in distance, the time taken to walk to school increases by 13.5 minutes.

[A1]

c. The point on the graph shows the actual time is 36 minutes (2.1, 36)

$$\text{The predicted time} = 2.5 + 13.5 \times 2.1 = 30.85$$

$$\begin{aligned} \text{Residual} &= \text{Actual time} - \text{Predicted time} \\ &= 36 - 30.85 = 5.15 \text{ minutes} \end{aligned}$$

[A1]

Question 5

a.

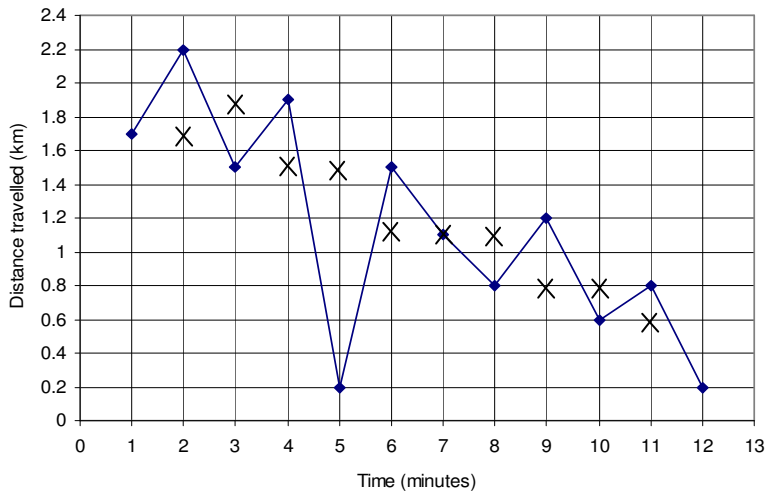

b. The distance travelled every minute decreases.

[A1]

[A1]

Total 15 marks

END OF CORE SOLUTIONS

Module 1: Number Patterns**Question 1****a.**

Starting with 5 and adding 3 each time until the eighth term is reached e.g. 5, 8, 11, 14, 17, 20, 23, 26
Alternatively use the arithmetic sequence formula where $n=8$, $a=5$ and $d=+3$

$$t_n = a + (n-1)d$$

$$t_8 = 5 + (8-1)3$$

$$t_8 = 5 + 21$$

$$t_8 = 26$$

[A1]**b.**

$$a = 5 \text{ and } d = +3$$

$$t_n = a + (n-1)d$$

$$t_n = 5 + (n-1)3$$

$$t_n = 5 + 3n - 3$$

$$t_n = 2 + 3n$$

[A1]**c.** Keep pattern going from 7th to 13th term i.e. 23+26+29+32+35+38 +41= 224 or

using $S_n = \frac{n}{2}[2a + (n-1)d]$ where $a=5$, $d=3$ to find **the sum of terms from 7th to 13th** or

$$S_{7 \text{ to } 13} = S_{13} - S_6$$

$$S_{13} = \frac{13}{2}[2 \times 5 + (13-1)3]$$

$$= 6.5[10 + 12 \times 3]$$

$$= 299$$

$$S_6 = \frac{6}{2}[2 \times 5 + (6-1)3]$$

$$= 3[10 + 5 \times 3]$$

$$= 75$$

$$S_{7 \text{ to } 13} = S_{13} - S_6$$

$$= 299 - 75$$

$$= 224$$

[A1]**d.**

Complete the tables as follows. For Anton's programme, to establish the simple pattern use the given sequence formula to generate a few terms.

For $n=1$

$$l_n = -3n + 44$$

$$l_1 = -3 \times 1 + 44$$

$$l_n = 41$$

For $n=2$

$$l_n = -3n + 44$$

$$l_2 = -3 \times 2 + 44$$

$$l_2 = -6 + 44$$

$$l_2 = 38$$

For $n=3$

$$l_n = -3n + 44$$

$$l_3 = -3 \times 3 + 44$$

$$l_3 = -9 + 44$$

$$l_3 = 35$$

Day n	Jane, t_n	Anton, A_n $C_n = -3n + 44$
1 -3 rd Nov	5	41
2 -4 th Nov	8	38
3 -5 th Nov	11	35
4 -6 th Nov	14	32
5 -7 th Nov	17	29
6 -8 th Nov	20	26
7 -9 th Nov	23	23
8 -10th Nov	26	20
9 -11 th Nov	29	17
10 -12 th Nov	32	14

[A1]

On the **10th of November**, the 8th day of the programme, Jane does **more laps** than Anton. [A1]

Question 2

a. $f_{n+2} = f_{n+1} + f_n$. $f_1 = 3, f_2 = 1$,

[A1]

b.

Keep the pattern going

$$f_3 = 4$$

$$f_4 = 5$$

$$f_5 = 9$$

$$f_6 = f_4 + f_5 = 5 + 9 = 14$$

$$f_7 = f_5 + f_6 = 9 + 14 = 23$$

$$f_8 = f_6 + f_7 = 14 + 23 = 37$$

The number of laps on the eightj day is 37 laps.

[A1]

Question 3**a.**

For geometric sequence

$$\frac{t_{n+1}}{t_n} = r$$

$$\frac{t_3}{t_2} = \frac{16}{40} = 0.4$$

$$\frac{t_2}{t_1} = \frac{40}{100} = 0.4$$

There is a common ratio equal to 0.4

[A1]**b.** This is a hypothetical question as all infinity problems are. However if it was to continue on itsjourney the given $S_\infty = \frac{a}{1-r}$ where $a = 100$ and $r = 0.4$.

$$\begin{aligned} S_\infty &= \frac{100}{1-0.4} \\ &= \frac{100}{0.6} \\ &= 166.\bar{6} \end{aligned}$$

[M1]Therefore as the total distance is less than 200 cm, then the snail **will not reach** a lettuce. (Note: answer mark only if supported by suitable working shown.)**[A1]****c.** The sum of the hourly distances travelled by the snail only needs to add up to 165 cm..

$$\begin{aligned} S_n &= \frac{a(1-r^n)}{(1-r)} \\ 165 &= \frac{100(1-0.4^n)}{(1-0.4)} \\ 165 &= 166.\bar{6}(1-0.4^n) \\ \frac{165}{166.\bar{6}} &= 1-0.4^n \\ 0.4^n &= 1-0.99 \\ 0.4^n &= 0.01 \\ n \log 0.4 &= \log(0.001) \\ n &= \frac{\log(0.01)}{\log 0.4} \\ n &= 5.026 \end{aligned}$$

Thus a little over 5 hours or in the 6th hour.**Alternatively**, use simple approach to the pattern of 100, 20, 4, 0.8, 0.16Or $100 + 40 + 16 + 6.4 = 162.4$ for total of 4 hours and $100 + 40 + 16 + 6.4 + 2.56 = 164.96$ for total of 5 hours. $100 + 40 + 16 + 6.4 + 2.56 + 1.024 = 165.984$ total of 6 hours.Thus during the 6th hour, the snail will reach the lettuce.**[A1]**

Question 4

- a. It has both an arithmetic and geometric component. So the difference equation is in the form of

$$J_{n+1} = aJ_n + b, \text{ where}$$

the common difference $b = +20$

[A1]

the common ratio is a decrease by 15% which means $r = 1 - 0.15 = 0.85$

[A1]

and the first term is 160 jobs

$$J_{n+1} = 0.85J_n + 20, \quad J_{2009} = 160$$

- b.

$$J_{n+1} = 0.85J_n + 20, \quad J_{2009} = 160$$

$$\begin{aligned} J_{2010} &= 0.85J_{2009} + 20 \\ &= 0.85 \times 160 + 20 \\ &= 156 \end{aligned}$$

$$\begin{aligned} J_{2011} &= 0.85J_{2010} + 20 \\ &= 0.85 \times 156 + 20 \\ &= 152.6 \end{aligned}$$

In 2010 there is an expected 153 jobs.

[A1]

- c. The percentage decrease must be equal to the 20 new jobs added as a percentage of 160 jobs.

$$\begin{aligned} \text{Percentage} &= \frac{20}{160} \times \frac{100}{1} \% \\ &= 12.5\% \end{aligned}$$

12.5% is the percentage decrease allowed to maintain a constant 160 jobs each year.

[A1]

Total 15 Marks**END OF MODULE 1 SOLUTIONS**

Module 2: Geometry and Trigonometry

Question 1

- a. Using the sine rule

$$\frac{\sin \theta}{20} = \frac{\sin 15^\circ}{18}$$

$$\sin \theta = \frac{\sin 15^\circ}{18} \times 20$$

$$\sin \theta = 0.287576\dots$$

$$\theta = \sin^{-1}(0.287576\dots)$$

$$= 16.7^\circ$$

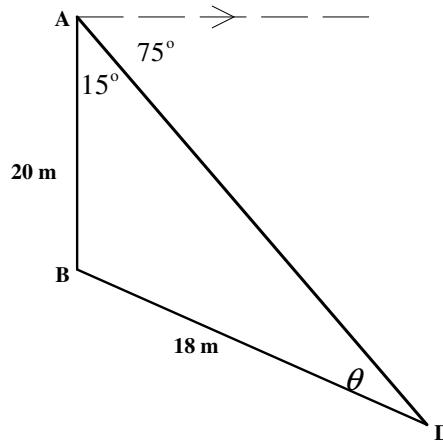

[M1]

$$\begin{aligned} \text{Angle ABD} &= 180^\circ - 15^\circ - 16.7^\circ \\ &= 148.3^\circ \end{aligned}$$

- b. Angle CBD = $180^\circ - 148.3^\circ = 31.7^\circ$

$$\text{Angle of elevation} = 90^\circ - 31.7^\circ = 58.3^\circ$$

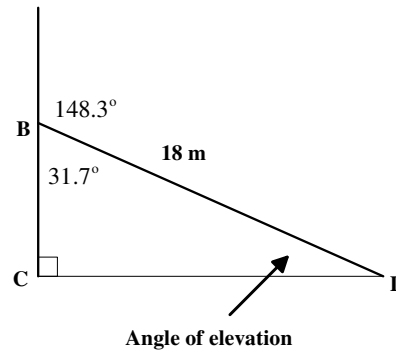

[A1]

[A1]

Question 2

- a. Using cosine rule

$$AB^2 = 15^2 + 10^2 - 2(15)(10)\cos(78^\circ)$$

$$\begin{aligned} AB &= \sqrt{262.626} \\ &= 16.21 \text{ km} \end{aligned}$$

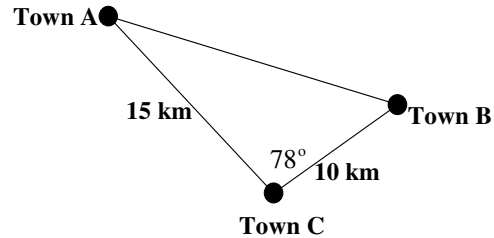

[M1]

- b.

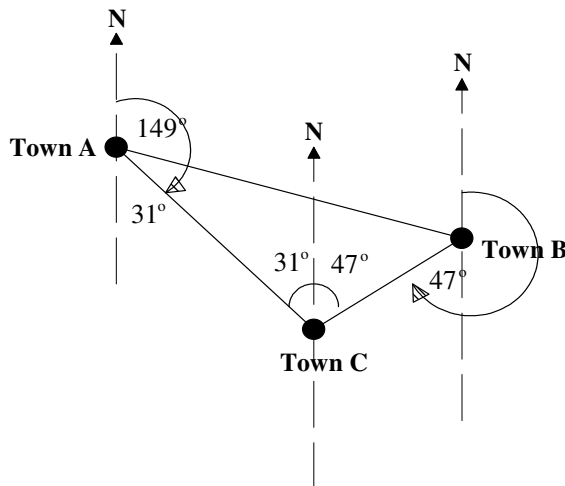

$$180^\circ - 149^\circ = 31^\circ$$

$$78^\circ - 31^\circ = 47^\circ$$

$$\text{Bearing is } 180^\circ + 47^\circ = 227^\circ T$$

[A1]

[A1]

[A1]

Question 3

a. $\theta = \frac{360}{8}$

[M1]

b. i.
$$\begin{aligned} \text{Area} &= \frac{1}{2} \times 15 \times 15 \times \sin 45^\circ \\ &= 79.55 \text{ cm}^2 \end{aligned}$$

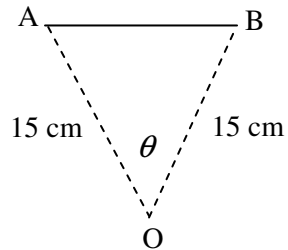

[A1]

ii.
$$\begin{aligned} \text{Area of octagonal paver} &= 8 \times 79.55 \\ &= 636.4 \text{ cm}^2 \end{aligned}$$

[A1]

c.
$$\begin{aligned} \text{Volume of octagonal paver} &= \text{Area of paver} \times \text{height} \\ &= 636.3961\dots \times 2.5 \\ &= 1590.990258\dots \text{ cm}^3 \text{ per paver} \end{aligned}$$

[M1]

$$100 \text{ pavers} = 159099 \text{ cm}^3 = \frac{159099}{100^3} \text{ m}^3 = 0.16 \text{ m}^3$$

[A1]

Question 4

- a. Given that $AD = BC$ and $AB \parallel CD$ and using symmetry the cross sectional height can be found using the right angle triangle ADX

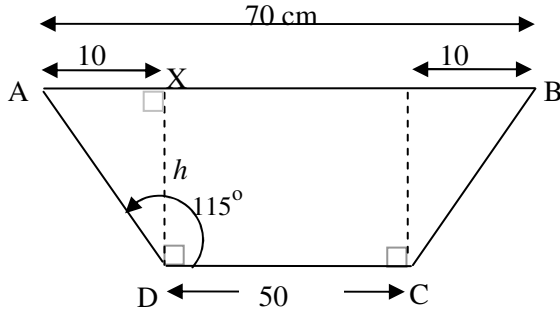

Angle $ADX = 115^\circ - 90^\circ = 25^\circ$

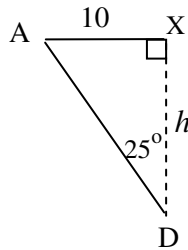

$$\tan 25^\circ = \frac{10}{h}$$

$$h = \frac{10}{\tan 25^\circ}$$

$$= 21.44 \text{ cm}$$

[A1]

- b.

The length is the same for the soil and container

Only 2 dimensions are similar

The area ratio is used here (not the volume ratio).

height ratio = $1 : 2$

area ratio = $1^2 : 2^2 = 1 : 4$

So the fraction of Volume full of soil is $\frac{1}{4}$

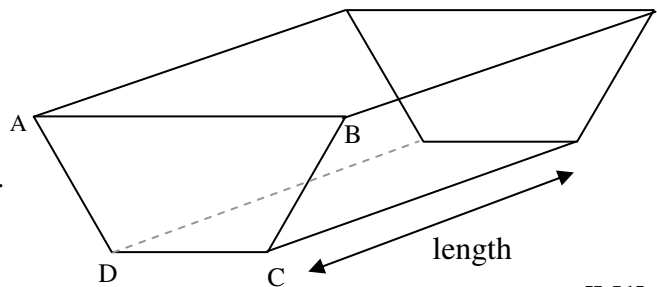

[M1]

[A1]

Total 15 Marks

END OF MODULE 2 SOLUTIONS

Module 3 Graphs and Relations

Question 1

a. Sam travels 9km in 60 minutes,

using ratios $\begin{matrix} 9\text{km} : 60 \text{ min} \\ 6\text{km} : x \text{ min} \end{matrix}$

$$x = \frac{6}{9} \times 60 = 40 \text{ minutes}$$

[A1]

b. Niko travels 18 km in 60 minutes.

In 15 minutes he travels

$$x = \frac{15}{60} \times 18 = 4.5 \text{ kilometres}$$

[A1]

c.

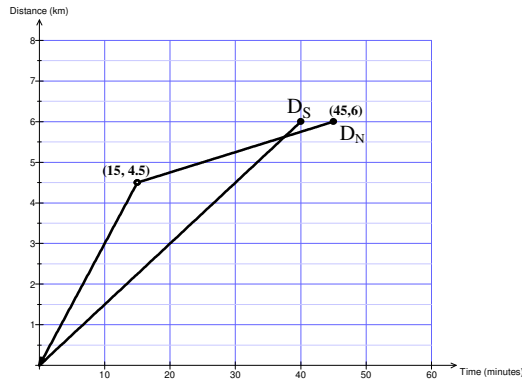

Line segment drawn from (0, 0) to (15, 4.5)

[A1]

Line segment drawn from (15, 4.5) to (45, 6)

[A1]

d. Find equation of the line segment joining (15, 4.5) to (45, 6)

$$\text{gradient} = \frac{6 - 4.5}{45 - 15} = \frac{1.5}{30} = \frac{1}{20} = 0.05$$

substitute 0.05 and one point on the line (15, 4.5) in $y = mx + c$

$$4.5 = 0.05 \times 15 + c$$

$$4.5 = 0.75 + c$$

$$c = 3.75$$

so $y = 0.05x + 3.75$ from 15 minutes to 45 minutes

$$b = 0.05$$

[A1]

$$c = 3.75$$

[A1]

$$d = 45$$

[A1]

e. $D_S = D_N$ when $0.15t = 0.05t + 3.75$

$$0.10t = 3.75$$

$$\therefore t = 37.5 \text{ minutes}$$

[A1]

Question 2

a. The company must produce at least 4 mountain bikes in a week [A1]

b. i. line starts at (0, 16) and ends at (24, 0) [A1]

ii.

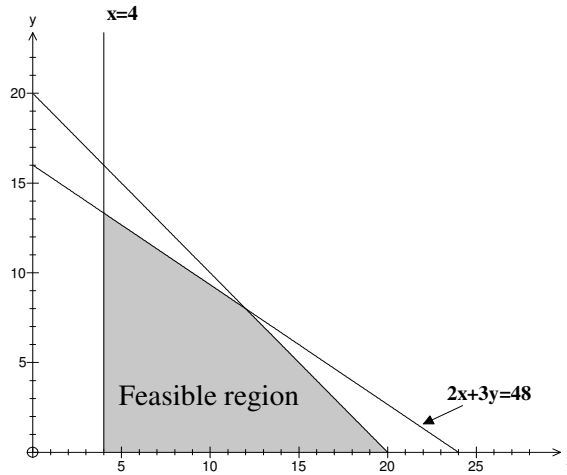

[A1]

c. $P = 30x + 45y$ [A1]

d. i.

Vertices	$30x + 45y$	Profit
(4, 0)	$P = 30 \times 4 + 45 \times 0$	120
(4, $13\frac{1}{3}$)	$P = 30 \times 4 + 45 \times 13\frac{1}{3}$	720
(12, 8)	$P = 30 \times 12 + 45 \times 8$	720
(20, 0)	$P = 30 \times 20 + 45 \times 0$	600

The maximum profit occurs at all integer points on the line joining (4, $13\frac{1}{3}$) and (12, 8). Equation of this line is $2x + 3y = 48$

[A1]

x	4	5	6	7	8	9	10	11	12
y	$13\frac{1}{3}$	$12\frac{2}{3}$	12	$11\frac{1}{3}$	$10\frac{2}{3}$	10	$9\frac{1}{3}$	$8\frac{2}{3}$	8

The maximum weekly profit occurs when 6 mountain bikes and 12 racers are sold
 or 9 mountain bikes and 10 racers are sold
 or 12 mountain bikes and 8 racers are sold

[A1]

e. The maximum profit is \$720

[A1]

Total 15 Marks

END OF MODULE 3 SOLUTIONS

Module 4: Business related mathematics

Question 1

a.

$$\begin{aligned} \text{GST Tax} &= \frac{\text{Price}}{11} \\ &= \frac{\$42000}{11} \\ &= \$3818.18 \\ &\approx \$3818 \end{aligned} \qquad \text{[A1]}$$

b.

$$\begin{aligned} BV &= P \left(1 - \frac{r}{100}\right)^T \\ &= 42000 \times \left(1 - \frac{22.5}{100}\right)^2 \\ &= 42000 \times 0.600625 \\ &= \$25226.25 \\ &= \$25200 \end{aligned} \qquad \text{[A1]}$$

Or show the table of values similar to those on a finance solver.

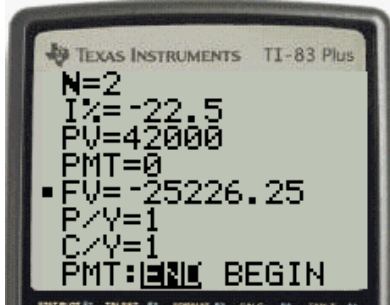

The bookvalue of the car after 2 years is \$25 200.

Question 2

a.

Cost price = \$42 000
 Deposit = \$2000
 Loan = \$40 000
 Hire purchase loan (simple interest)

$$\begin{aligned} I &= \frac{PrT}{100} \\ &= \frac{40\,000 \times 2 \times 7.2}{100} \\ &= \$5760 \end{aligned} \qquad \text{[A1]}$$

$$\begin{aligned} \text{Monthly repayments} &= \frac{(5760 + 40\,000)}{24} \\ &= \$1906.67 \end{aligned}$$

b.

Total cost = loan + interest + deposit
 = \$40 000 + \$5760 + \$2000
 = \$47 760

Extra Cost = interest charged as calculated above \$5760 or
 = \$47 760 - \$42 000 = \$5760

[A1]

Question 3

a.

$$\begin{aligned} \text{employer's contribution} &= 9\% \times \frac{\$60000 \text{ pa}}{12 \text{ months}} \\ &= \$450 \end{aligned}$$

[A1]

b.

$$\begin{aligned} \text{Total contribution} &= \$450 + \$400 \\ &= \$850 \end{aligned}$$

[A1]

c.

$$\begin{aligned} n = \text{number of payments} &= 5 \text{ years} \times 12 \text{ monthly} \\ &= 60 \end{aligned}$$

P = principal or initial amount in fund = \$120 000

Q = monthly payments = \$850 (from part b)

R = compounding factor

$$\begin{aligned} &\frac{r\%}{100} \\ &= 1 + \frac{9\%}{100} \\ &= 1 + \frac{12}{100} \\ &= 1.0075 \end{aligned}$$

[A1]

n =60	P =12 000	R =1.0075
-------	-----------	-----------

[A1]

d.

$$\begin{aligned} A &= PR^n + \frac{Q(R^n - 1)}{R - 1} \\ &= 120\,000 \times 1.0075^{60} + \frac{850(1.0075^{60} - 1)}{1.0075 - 1} \\ &= \$251\,992.24 \\ &\approx \$252\,000 \end{aligned}$$

[A1]

Or show the table of values similar to those on a finance solver.

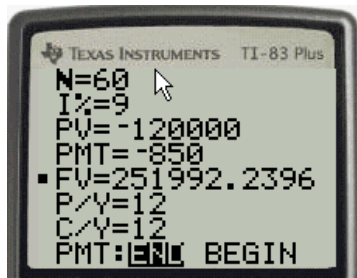

Question 4

a.

$P = \text{funds available} = \$252\,000$ (from question 3.d.)

$$r\% = 8\% \text{ pa} = \frac{8}{12} \% \text{ per month}$$

$$= \frac{2}{3} \% \text{ per month}$$

$$Q = \frac{Pr}{100}$$

$$= \frac{\$252\,000 \times \frac{2}{3}}{100}$$

$$= \$1680 \text{ per month}$$

OR

$$Q = \frac{Pr}{100n}$$

$$= \frac{\$252\,000 \times 8}{100 \times 12}$$

$$= \$1680 \text{ per month}$$

[A1]

b.

$$\text{Salary} = \$1680 \text{ per month}$$

$$= 1680 \times 12$$

$$= \$20\,160 \text{ per year}$$

$$\text{Percentage} = \frac{20160}{60000} \times \frac{100}{1} \%$$

$$= 33.6\%$$

[A1]

c.

$n = \text{number of payments} = 25 \text{ years} \times 12 \text{ monthly} = 300$

$P = \text{principal amount in fund} = \$252\,000$

$R = \text{compounding factor}$

$$= 1.00666667$$

[M1]

$$Q = \frac{PR^n(R-1)}{R^n-1}$$

$$= \frac{252000 \times 1.006667^{300} (1.006667 - 1)}{1.006667^{300} - 1}$$

$$= \$1944.98$$

[A1]

Or show the table of values similar to those on a finance solver.

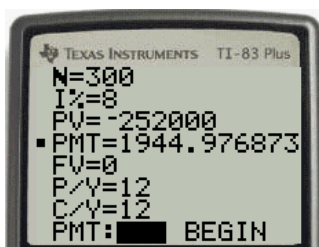

d.

- i. For perpetuity the funds are always maintained therefore the inheritance would be the \$252 000 initially invested from the superannuation fund.

[A1]

ii.

$$\begin{aligned}
 A &= PR^n - \frac{PR^n(R-1)}{R^n-1} \\
 &= 252000 \times 1.00667^{180} - \frac{1944.98 \times (1.00667^{180} - 1)}{1.00666667 - 1} \\
 &= \$160306.792
 \end{aligned}$$

Or show the table of values similar to those on a finance solver.



The estate would inherit \$160 000 from the balance of the reducing balance annuity.

[A1]

Total 15 Marks

END OF MODULE 4 SOLUTIONS

Module 5: Networks & decision mathematics

Question 1

a. 7

[A1]

b.

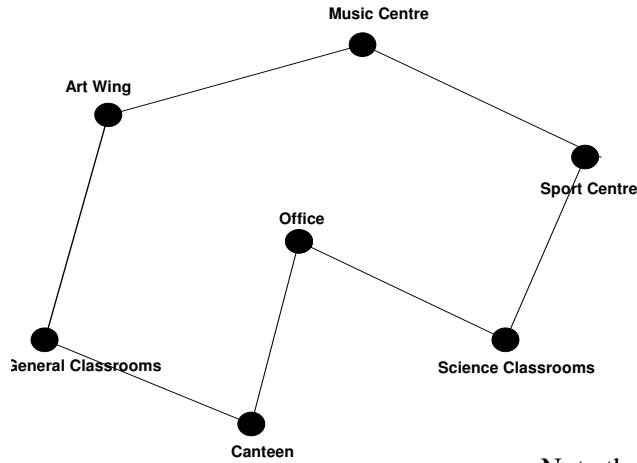

Note that other answers are possible [A1]

Question 2

a. $\frac{2}{7}$

[A1]

b. A Hamiltonian circuit visits each vertex once. To achieve the shortest Hamiltonian circuit, select the edge containing the smallest distance.

Office → Canteen → Science → Sport → Music → Art → General → Office is not the shortest

This circuit gives a distance of $50+75+250+100+120+160+70 = 825$ m

Office → Science → Sport → Music → Art → General → Canteen → Office is the **shortest circuit**

[A1]

and gives a distance of $60+250+100+120+160+80+50 = 820$ m

c. i. An odd degree vertex, either the canteen or music centre

[A1]

ii. Vertices with a degree of 4 will be passed twice.
The Science classrooms, General classrooms and Office.
Three buildings

[A1]

Question 3

a. Gabby must take Technical support so this leaves Eric with reports [A1]

b.

Staff Member	Position
Gabby	Technical Support
Mark	Curriculum
Kate	Student Welfare

2 correct [A1]

all correct [A1]

Question 4

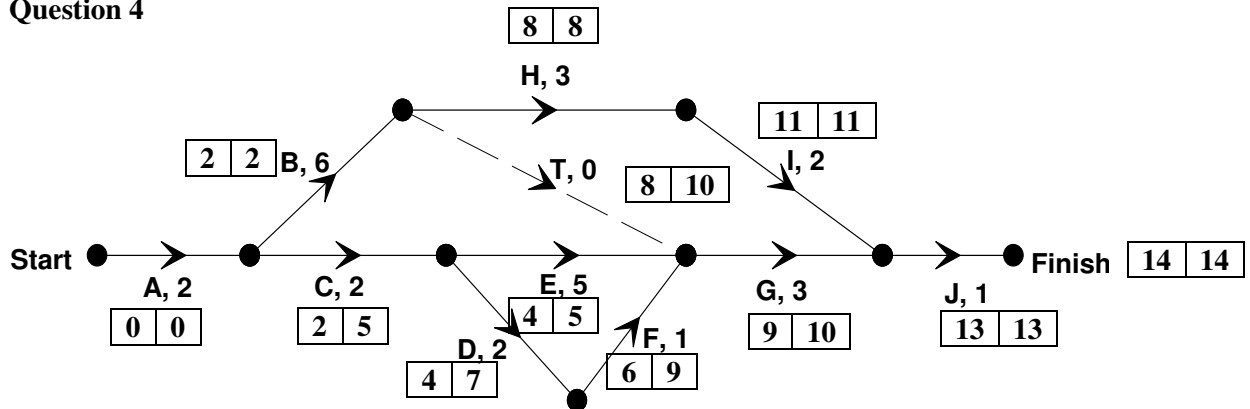

a.

Activity	Immediate Predecessor (s)	Duration (hours)	EST (hours)
G	B, E, F	3	9

B,E,F [A1]

9 [A1]

b. 14 hours [A1]

c. H is on the critical path ABHIJ and therefore any delay in H affects the entire project. [A1]

d. D and F can be delayed up to 3 hours. [A1]

e. The project will be delayed by 2 hours in total.
The new critical path is ACEGJ with a time of $13+3 = 16$ hours.
This gives 2 more hours than the original 14 hours. [A1]

Total 15 Marks

END OF MODULE 5 SOLUTIONS

Module 6: Matrices

Question 1

a.

	Today is dry	Today is wet
Next day is dry	0.85	0.48
Next day is wet	0.15	0.52

[A1]

b. To find the long-term probabilities, set n to a large number say 50.

$$S_{50} = T^{50} \times S_0$$

$$S_0 = \begin{bmatrix} 0 \\ 1 \end{bmatrix} \text{ if the given day is wet.}$$

$$S_{50} = \begin{bmatrix} 0.85 & 0.48 \\ 0.15 & 0.52 \end{bmatrix}^{50} \begin{bmatrix} 0 \\ 1 \end{bmatrix}$$

$$= \begin{bmatrix} 0.7619047619 \\ 0.2380952381 \end{bmatrix}$$

[M1]

$$= \begin{bmatrix} \frac{16}{21} \\ \frac{5}{21} \end{bmatrix}$$

If initially the day is wet then there is a 24 % chance it will be wet the next day.
 If initially the day is dry then there is a 76 % chance it will be dry the next day.

[A1]

c. Let Thursday, the first day of the Grand Prix is wet be $S_1 = \begin{bmatrix} 0 \\ 1 \end{bmatrix}$ and Sunday be S_4 .

$$S_4 = T^3 S_1$$

$$S_4 = \begin{bmatrix} 0.85 & 0.48 \\ 0.15 & 0.52 \end{bmatrix}^3 \begin{bmatrix} 0 \\ 1 \end{bmatrix}$$

$$= \begin{bmatrix} 0.723312 \\ 0.276688 \end{bmatrix}$$

$$S_3 = T^3 S_0$$

$$S_3 = \begin{bmatrix} 0.85 & 0.48 \\ 0.15 & 0.52 \end{bmatrix}^3 \begin{bmatrix} 0 \\ 1 \end{bmatrix}$$

$$= \begin{bmatrix} 0.723312 \\ 0.276688 \end{bmatrix}$$

or alternatively

There is approximately a 72.3% chance that it will dry on Sunday (four days later).

[A1]

Question 2

- a. Need to set up a 1×3 , with only the prices of general admission included as shown so that it can be multiplied with the given matrix, N_{2009} which is a 3×1

$$T_{2009} = [40 \quad 72 \quad 120] \quad \text{[A1]}$$

This is a difficult questions that requires due consideration to how the elements are multiplied together eg **rows of first** matrix by **column of the second** matrix. So the ticket price matrix only was allowed to have the admission prices, and order is important.

Revenue = Number of tickets x Ticket prices

$$\text{Revenue} = T_{2009} \times N_{2009}$$

$$\begin{aligned} \text{Revenue} &= [40 \quad 72 \quad 120] \begin{bmatrix} 80\,000 \\ 120\,000 \\ 20\,000 \end{bmatrix} \\ &= [14\,240\,000] \end{aligned}$$

OR

$$\text{Revenue} = T_{2009} \times N_{2009}$$

$$\begin{aligned} \text{Revenue} &= [80\,000 \quad 120\,000 \quad 20\,000] \begin{bmatrix} 40 \\ 72 \\ 120 \end{bmatrix} \\ &= [14\,240\,000] \end{aligned}$$

Total Revenue is \$14 240 000. [A1]

- b. To pre-multiply, the matrix needs to have 3 columns so the suitable matrix needs to be a 1×3 matrix as it needs to have the same number of columns as rows in the second matrix.

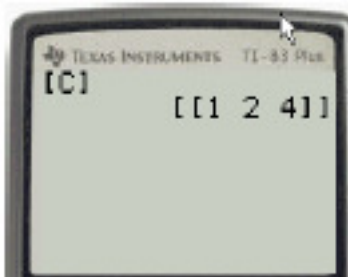

[A1]

- c. There were 428 800 spectators with general admission that passed through all 4 days. [A1]

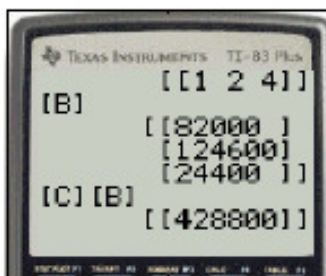

Question 3

- a. 2010 ticket prices is 12½% increase on the prices of the 2009 AGP tickets or
 2010 ticket prices is 100% + 12½% on the prices of the 2009 AGP tickets or
 2010 ticket prices is 1.125 × 2009 AGP tickets

$$T_{2010} = 1.125 \times T_{2009}$$

$$T_{2010} = 1.125 \begin{bmatrix} 40 & 160 & 800 \\ 72 & 320 & 1600 \\ 120 & 440 & 2400 \end{bmatrix}$$

$$= \begin{bmatrix} 45 & 180 & 900 \\ 81 & 360 & 1800 \\ 135 & 495 & 2700 \end{bmatrix}$$

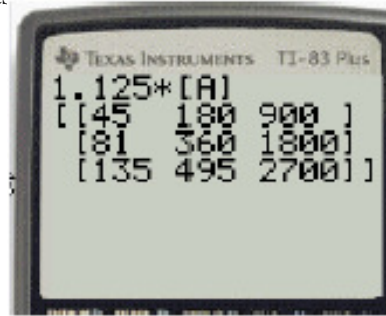

[A1]

- b. This is a single day VIP Box ticket.
 The element $t_{1,3}$ is row 1 column 3 and is \$900.

[A1]

[A1]

Question 4

- a. Transpose the formulas to get C and m on the same side.

$$C - 0.60m = 20$$

$$C - 0.30m = 30$$

And is represented in matrix form as

$$\begin{bmatrix} 1 & -0.6 \\ 1 & -0.3 \end{bmatrix} \begin{bmatrix} C \\ m \end{bmatrix} = \begin{bmatrix} 20 \\ 30 \end{bmatrix}$$

[A1]

- b. $\text{Det} = ad - bc$
 $= 1 \times -0.3 - -1 \times 0.6$
 $= -0.3 + 0.6$
 $= +0.3$

[A1]

Determinant not equal to zero means there is a solution or point of intersection and this is when the cost is the same for the same given number of minutes of talk time for both mobile carriers. [A1]

- c. $\begin{bmatrix} C \\ m \end{bmatrix} = \frac{1}{0.3} \begin{bmatrix} -0.3 & 0.6 \\ -1 & 1 \end{bmatrix} \begin{bmatrix} 20 \\ 30 \end{bmatrix}$
 $= \begin{bmatrix} 40 \\ 33\frac{1}{3} \end{bmatrix}$

$33\frac{1}{3}$ minutes of talk time.

[A1]

Total 15 marks

END OF SOLUTIONS