

Specific instructions

This paper consists of a core and five modules. Students should answer **all** questions in the core and then select **three** modules and answer **all** questions within the modules selected.

Core : Data analysis

A Melbourne swimming pool operator, Brendan, has collected attendance data for the 31 days in January 2001, as well as the maximum daily temperature for each of these days. He has used a stemplot to display the attendance data:

Stem	Leaf
15	3
16	1 1 6 8
17	0 2 4 9
18	0 1 1 8
19	1 4 6 9
20	0 0 4 9
21	0 3 7 7
22	4 5 9
23	5
24	0 4

Question 1

- a. Construct a boxplot for the attendance data using the axis below.

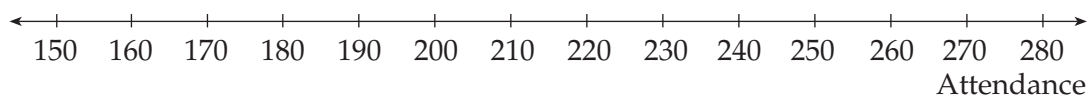

2 marks

- b. Describe the boxplot in terms of
i shape

ii centre

iii spread

3 marks

Brendan is keen to investigate the association between temperature and attendance at his pool so he has plotted, on the following scatterplot, the variable **attendance** against the variable **maximum daily temperature** ($^{\circ}\text{C}$):

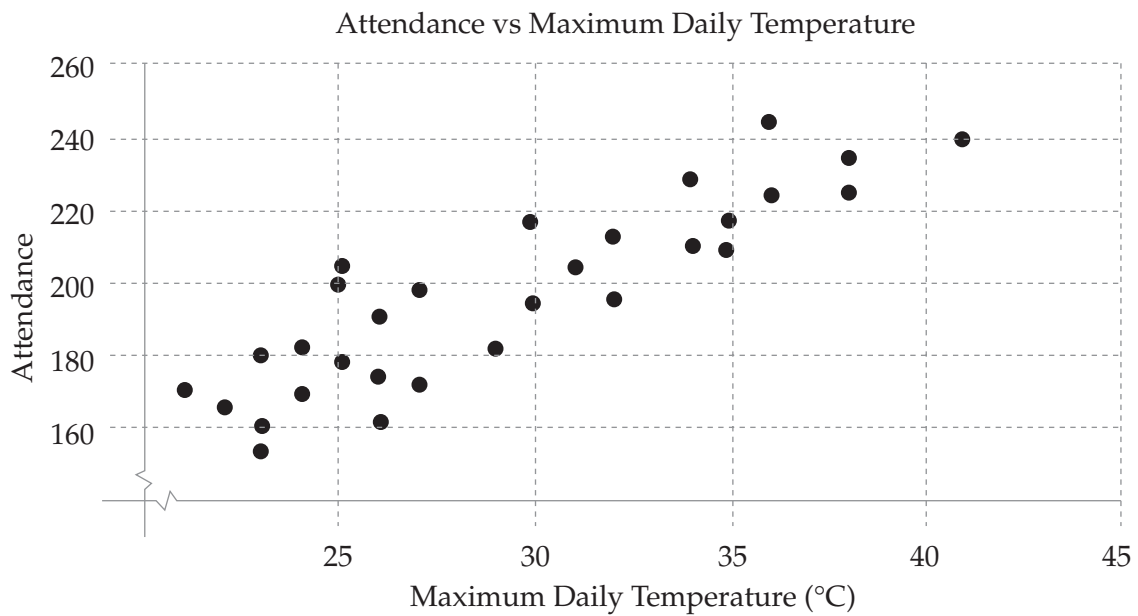

Using a statistics package Brendan has found that the product-moment correlation coefficient, r , is **0.884** and that the least-squares regression line equation has a **slope of 4.01** and an **intercept of 79.3**

Question 2

- a. i Describe, in terms of direction, the association between the variables **maximum daily temperature** and **attendance**.

- ii Complete the following interpretation of the direction:

As **maximum daily temperature** increases _____

2 marks

- b. Write the least-squares regression line equation in terms of the variables.

2 marks

- c. Complete the following interpretation of the **slope** of the regression line:
For each degree increase in **maximum daily temperature** the **attendance** _____

1 mark

- d. Use the regression line equation to predict the attendance for 20°C and 35°C and use these points to draw the regression line on the scatterplot.

3 marks

e. i Calculate the coefficient of determination correct to 3 decimal places.

ii Complete the following interpretation of the coefficient of determination:

_____ percent of the variation in **attendance** can be explained by _____

2 marks

Total 15 marks

Module 1 : Number patterns and applications

A new theatre complex is to be built. The lower level seating arrangement is designed as a semi-circle around a central stage with two main aisles dividing the seating as shown below. Each of the three sections has the same number of seats.

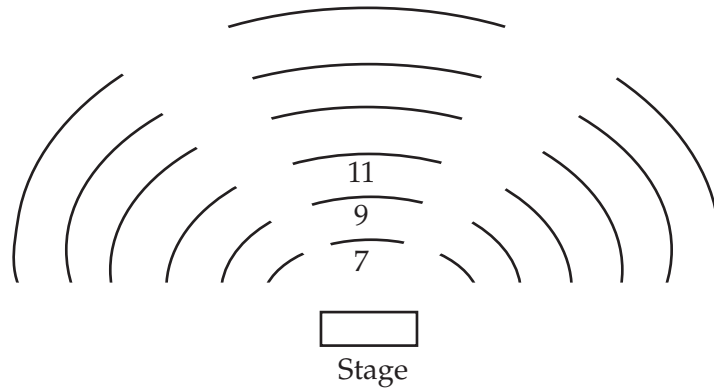

Question 1

The **centre section** starts with 7 seats in the first row, 9 in the second row, 11 in the third row and so on.

- a. How many seats are there in the next two rows, following the given pattern.

1 mark

- b. Using the information about the first three rows, **show mathematically** that the number of seats follows an arithmetic pattern.

1 mark

- c. If there is a total of 25 rows in the section, what is the total seating capacity of the section and hence the total seating capacity of the three sections shown above.

2 marks

- d. The upper dress circle on the second level has a total capacity such that the ratio of seats in the upper circle to the seats in the lower level is in the ratio of 10 : 25. How many seats are there in **total for the entire theatre** (lower and upper dress circle)?

3 marks

Question 2

A theatre production company is experiencing a decline in ticket sales. The number of tickets sold in each of the first 5 weeks is shown in the table below.

Week Number	1	2	3	4	5
Total Weekly Ticket Sales	30000	27000	24300	21870	19683

- a. Show that it is geometric sequence with $r = 0.9$.

1 mark

- b. Complete the following quote from the theatre owner.

“ The current show is experiencing a decline in ticket sales of _____% each week.”

1 mark

The owner has a policy that a show is cancelled once the total weekly sales goes below 7000.

- c. Calculate in which week it is expected that the show will be closed if this policy is enforced.

2 marks

Question 3

After the first week the producer attempts to promote the show so that the season can be extended. The promotion is that each week 50 tickets are given away as prizes. With this promotion and the media exposure he can assume that there will only be a 5% decrease of the previous weekly ticket sales and the show will be extended by an extra 4 months.

A difference equation that would generate values of t_n (weekly ticket sales) has the form:

$$t_{n+1} = at_n + b; \quad t_1 = 30\,000$$

- a. Write down the values of a and b .

1 mark

- b. State whether or not the theatre show can be expected to be extended to the 30th week. Show your calculations.

3 marks

Total 15 marks

Module 2 : Geometry and trigonometry

David and Anna are considering buying an irregularly shaped block of land. The block is bounded on two sides by roads running North-South and East-West.

They have been given a plan of the block showing some of the boundary lengths and some of the angles. The estate agent has told them that the area of the block is approximately 1200 square metres.

The block is the quadrilateral ABCD on the diagram below.

The road frontage AB is 30 metres long, the road frontage AD is 33 metres long and the boundary BC is 32.5 metres long.

$\angle ABC = 125^\circ$ and $\angle DAB$ is a right angle.

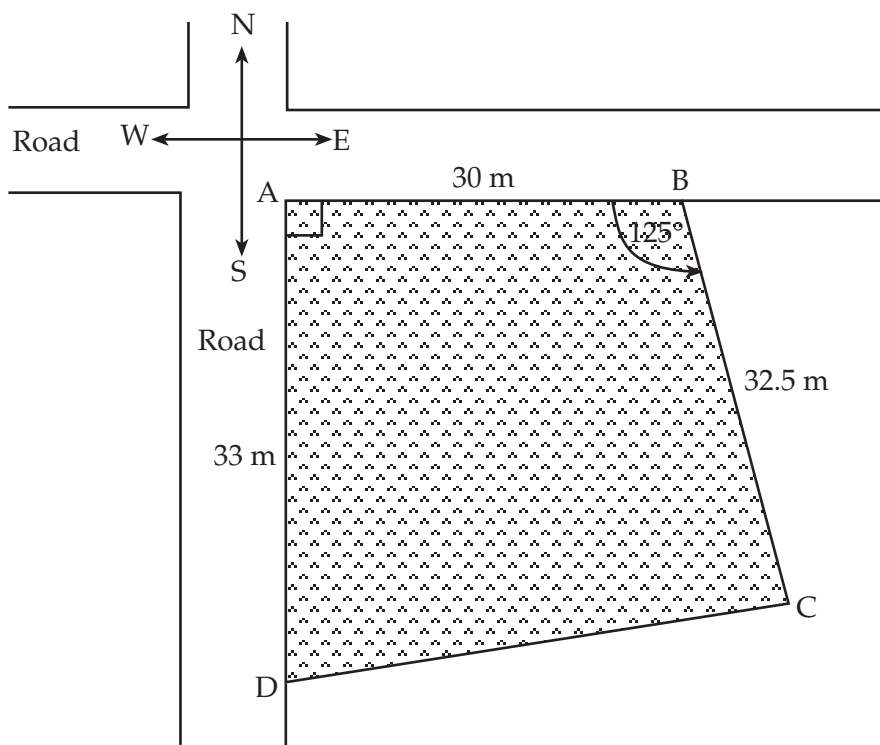

David and Anna are interested to find a more accurate estimation of the area of the block.

Question 1

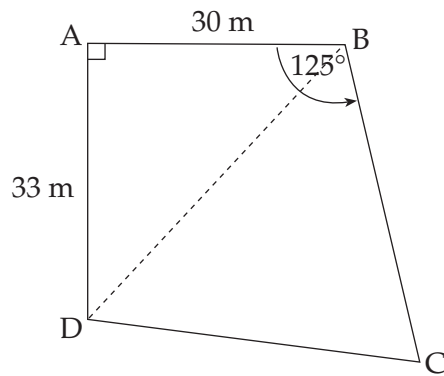

- a. Calculate the length of the diagonal DB. Give your answer in metres correct to two decimal places.

2 marks

- b. i. Calculate the size of $\angle ABD$. Give your answer in degrees correct to two decimal places.

2 marks

b. ii. Show that $\angle DBC = 77.27^\circ$ correct to two decimal places.

1 mark

c. Calculate the area of the triangle DAB in m^2 .

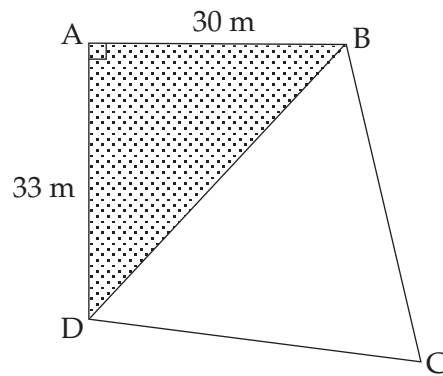

2 marks

- d. Calculate the area of triangle DBC. Give your answer in square metres correct to two decimal places.

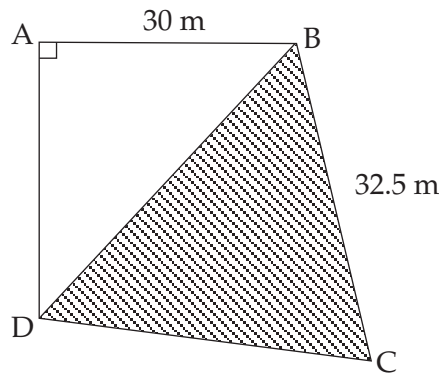

2 marks

- e. The estate agent told David and Anna that the area of the block was approximately 1200 square metres. By how many square metres did the estate agent over or under estimate the area of the block?

1 mark

David and Anna would like to know the length and bearing of the boundary DC also.

Question 2

- a. Use your calculations from Question 1, to calculate the length of boundary DC. Give your answer in metres correct to two decimal places.

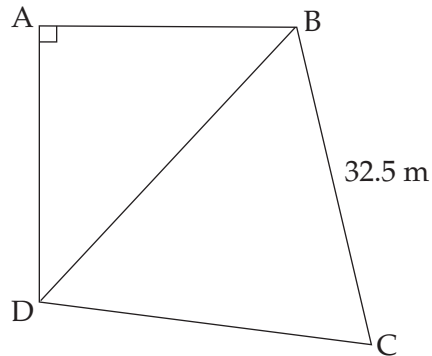

2 marks

- b. Find the size of $\angle BDC$ and hence the bearing of point C from point D.
Give your answers correct to the nearest degree.

3 marks

Total 15 marks

Module 3 : Graphs and relations

An amateur rock band, Decianimals, is planning an outdoor concert on farmland on the outskirts of a town.

Jeff, the sound technician, is concerned about the level of sound from the speakers located near the stage. He measures the sound intensity level at various distances from the speakers. The table below shows the results.

Distance from Speakers , x (metres)	5	10	20	40
Sound Intensity, I	0.1	0.025	0.00625	0.001563

Question 1

- a. The data was graphed as shown. The graph is missing a conventional label.

Fill in the missing label:

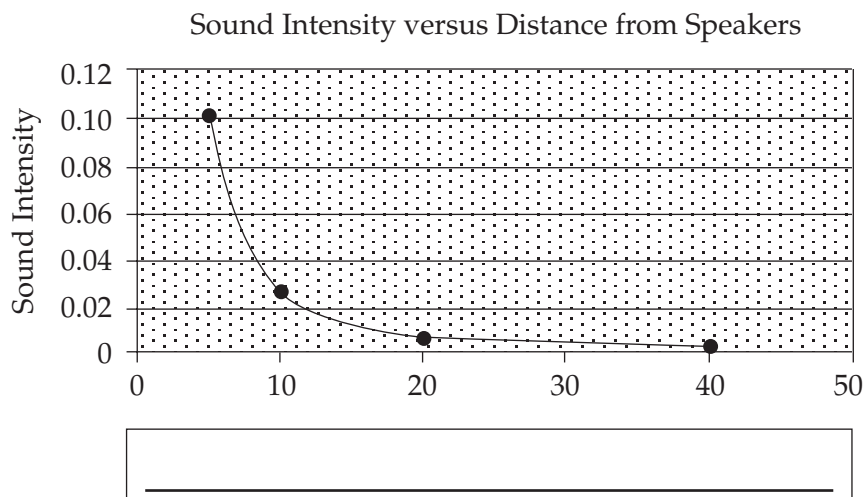

1 mark

Jeff recognizes the shape of the curve but realizes the relationship could be either of the form $y = \frac{k}{x}$ or $y = \frac{k}{x^2}$ as only the first quadrant of the Cartesian plane is shown.

Jeff suspects the relationship between Sound Intensity (I) and Distance from Speakers (x) is given by the equation $I = \frac{k}{x^2}$.

b. Complete the table below necessary for further investigation of the value of k .

Distance from Speakers, x (metres)	5	10	20	40
$\frac{1}{x^2}$				
Sound Intensity, I	0.1	0.025	0.00625	0.001563

1 mark

c. Plot each point on the graph provided. One of the points has been plotted for you.

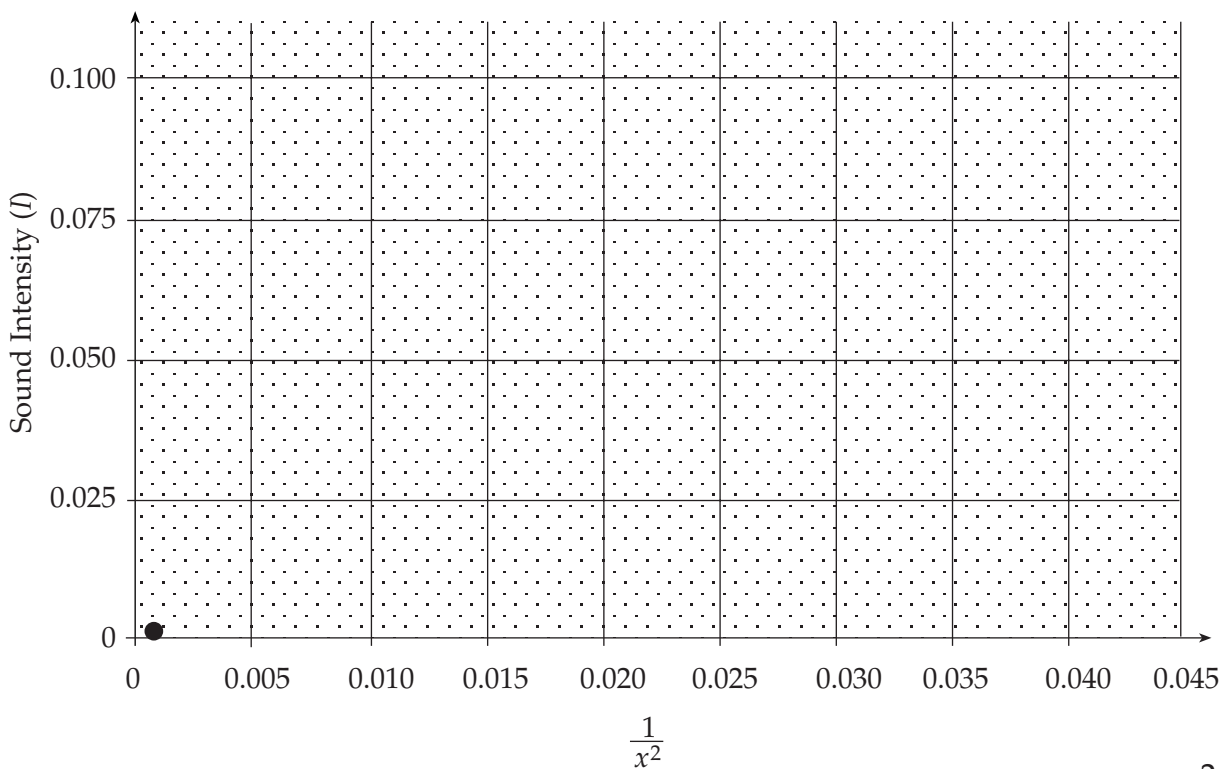

2 marks

d. Is the relationship of the form $I = \frac{k}{x^2}$? Give a reason.

1 mark

e. From the graph or using another method, calculate the value of k .

2 marks

Question 2

Law requires that liability insurance be taken out and the cost is high so they are limited to a total audience of 1000 people.

The band members decide to divide the seating area for the audience into two sections taking into consideration that people at distances beyond 40 metres will experience reduced sound levels. In the front section the numbers are to be limited to 600 people.

Let x represent the number of people in the front section
and y represent the number of people in the section beyond 40 metres.

The above constraints on these variables can be stated and these constraints may be used to form five inequations (below).

a. Give the two missing inequations.

1. $y \geq 0$

2. $y \leq 1000$

3. $x \geq 0$

4. _____

5. _____

2 marks

- b. Graph this set of constraints on the axes provided, label the co-ordinates of the point of intersection and clearly indicate the feasible region.

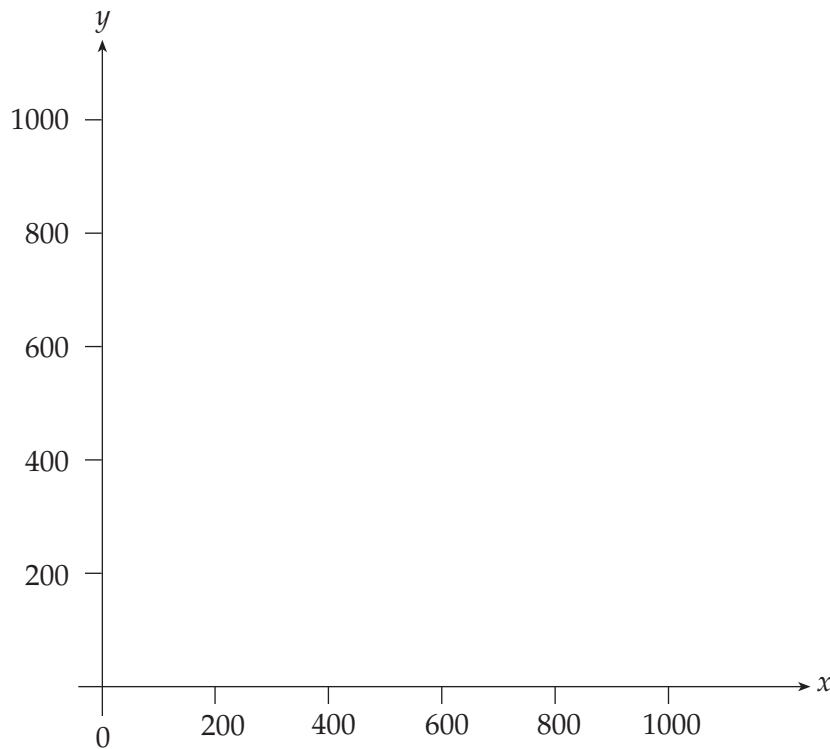

3 marks

To recover their costs and possibly make a profit they charge the following amounts for the concert tickets.

- \$10 a head (section up to 40 metres from stage)
- \$5 a head (section beyond 40 metres)

- c. Write down the objective function for ticket sales, Z , in terms of x and y .

1 mark

- d. Determine the maximum amount of money from ticket sales they can make from the concert and the number in each section of the audience in order to achieve this amount.

2 mark

Total 15 marks

Module 4 : Business related mathematics

Bob is planning to buy a house at some time in the future. He wants to wait until he has saved at least \$30 000 for the deposit. He currently has \$20 000 available to him and wishes to obtain the remaining funds through the interest on his investments.

Question 1

Bob decides to make two investments as follows:

INVESTMENT A – \$10 000 to be placed in an account earning 7.5% per annum simple interest

INVESTMENT B – \$10 000 to be placed in an account earning 7% per annum compounding annually

- a. Determine the amount of interest Bob must earn before he reaches his savings target.

1 mark

- b. The table below shows the amount of interest earned in the first year for each investment. Calculate the amount of interest earned **in the second year** for each investment and **enter in the table**.

	Investment A	Investment B
Interest earned in year 1 (\$)	750	700
Interest earned in year 2 (\$)		

2 marks

Bob decides to draw a graph that shows the value of each investment at the end of each year. As both investments began at \$10 000 he plots (0, 10000) for each and knowing the interest earned in year 1, he plots (1, 10750) and (1, 10700) for Investments A and B respectively.

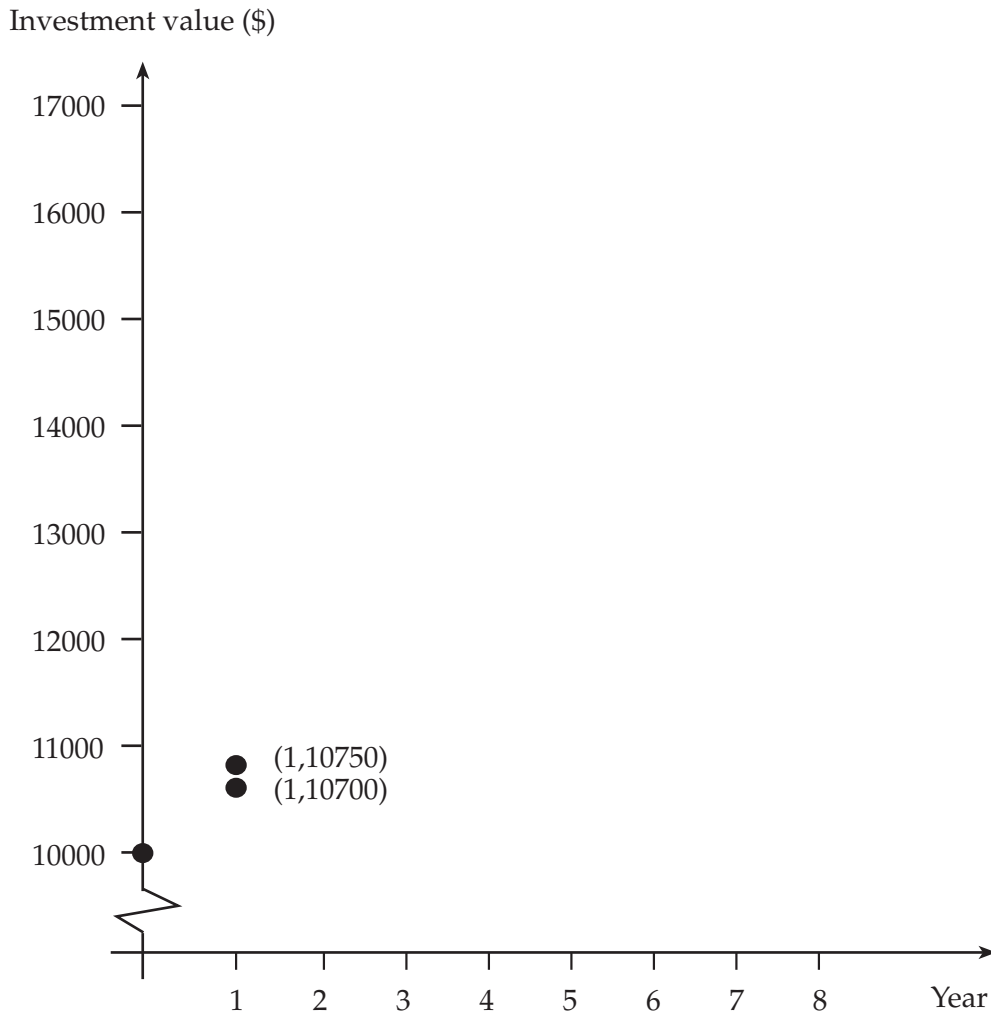

- c. Plot the appropriate point for each investment for the end of year 2 on the axes provided above. 1 mark
- d. Draw the **basic shape** of each graph over an eight year period on the axes. Clearly label each graph. 2 marks
- e. After which year is the value of each investment equal from the graph?

1 mark

In order to reach his savings target, Bob decides he will maintain each investment until **both** have a value of at least \$15 000.

f. At the end of which year will this first occur ?

2 marks

Question 2

Having finally reached savings of \$30 000, Bob purchases a home for \$210 000. He uses the full \$30 000 as a deposit and borrows \$180 000 over 25 years at 6% per annum on the reducing monthly balance.

- a. If Bob uses the annuity formula

$$A = PR^n - \frac{Q(R^n - 1)}{R - 1} \quad \text{where} \quad R = 1 + \frac{r}{100}$$

determine the values of n and R that he will require to pay off the loan.

2 marks

- b. Calculate the monthly repayments that Bob will have to make. Give your answer correct to the nearest cent.

2 marks

- c. Calculate the total amount of interest that Bob would pay over the term of the loan. Give your answer correct to the nearest dollar.

1 mark

- d. How would Bob's total payments to the bank have altered had he originally taken out the loan with a deposit of \$20 000 rather than saving the extra \$10 000 deposit first? Explain your answer briefly.

1 mark

Total 15 marks

Module 5 : Networks and decision mathematics

A training drill at Yallambie football club involves 7 cones (labelled A-G) placed at various points on the field. The following network represents the distances (in metres) between the cones.

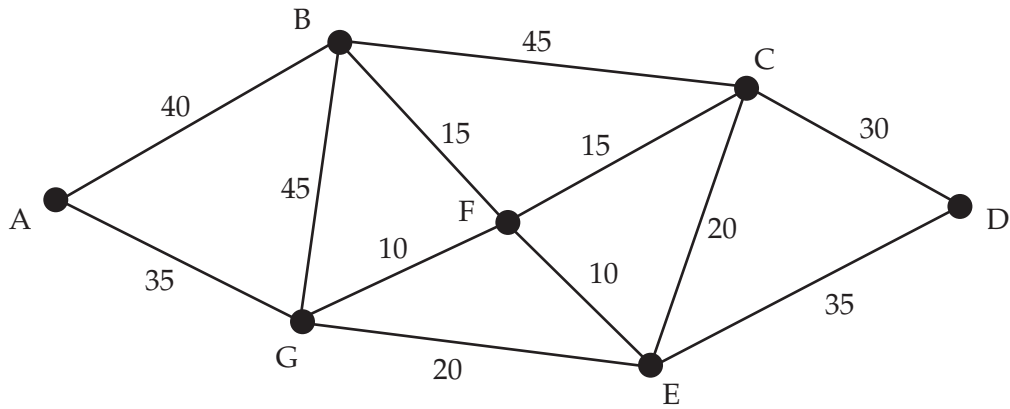

Question 1

a. Explain why an Euler circuit exists for this network.

1 mark

b. Name an Euler circuit for this network.

1 mark

c. Name a path where a player starts from cone A, passes each cone only once and finishes back at A.

1 mark

d. Draw a minimum spanning tree for this network.

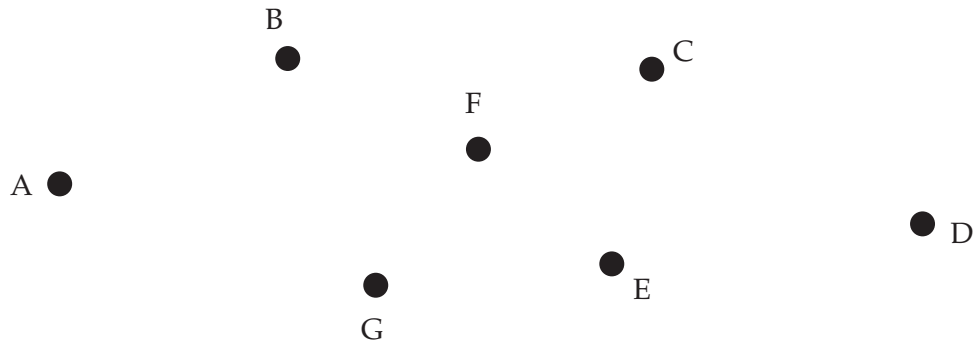

1 mark

e. Determine the weight of the minimum spanning tree.

1 mark

Question 2

The coaching staff at Yallambie have identified the following list of activities that must be completed prior to each training session. These activities, their durations and any necessary predecessors are represented in the following table

	Activity	Duration (mins)	Predecessors
A	Unlock dressing sheds	2	–
B	Unlock medical rooms	1	–
C	Write instructions on whiteboard	5	A
D	Set up first aid facilities	4	B
E	Carry equipment to oval and set up	3	A
F	Address players in dressing sheds	6	C,D
G	Conduct warm ups on oval	7	E,F

a. Complete the project network shown below

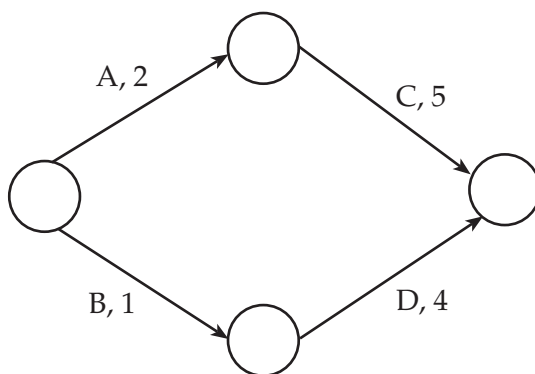

2 marks

b. Complete the following table

Activity	Earliest start time	Latest start time
A	0	0
B	0	2
C	2	2
D	1	
E	2	10
F		7
G	13	13

2 marks

c. Name the critical path for this project.

1 mark

d. Determine the project completion time.

1 mark

e. Training is conducted under lights and local council regulations insist that the lights are switched off at 8 p.m. The club will be fined \$10 per minute if the lights are turned off after the deadline. If everything runs to plan, the coaches turn the lights off at exactly 8 p.m. On a night when everything else ran perfectly to time determine the fine imposed if an extra 3 minutes were used to set up the **first aid facilities**.

1 mark

Question 3

The four members of the coaching staff are Ken, Mark, Richard and Tony. On a weekend when Yallambie has a bye, each will watch one of the other 4 games being played. The following table shows the distance that each coach would have to travel in kilometres to each of the 4 ovals.

	Oval 1	Oval 2	Oval 3	Oval 4
Ken	14	9	20	12
Mark	15	10	23	13
Richard	9	11	27	9
Tony	15	16	21	12

Using the Hungarian algorithm, or otherwise, assign each coach to a match so as to **minimise** the overall distance that must be travelled.

3 marks

Total 15 marks