



# THE SCHOOL FOR EXCELLENCE (TSFX)

## UNIT 4 CHEMISTRY 2009

### WRITTEN EXAMINATION 2

Reading Time: 15 minutes  
Writing Time: 1 hour 30 minutes

#### QUESTION AND ANSWER BOOK

##### Structure of Booklet

<i>Section</i>		<i>Number of Questions</i>	<i>Number of Questions to be Answered</i>	<i>Number of Marks</i>	<i>Suggested Times (min)</i>
A	Multiple choice questions	20	20	20	20
B	Short answer questions	8	8	62	62
				Total 82	Total 82

#### COMPLIMENTS OF THE SCHOOL FOR EXCELLENCE

Voted Number One For Excellence and Quality in VCE Programs and Tutorials.

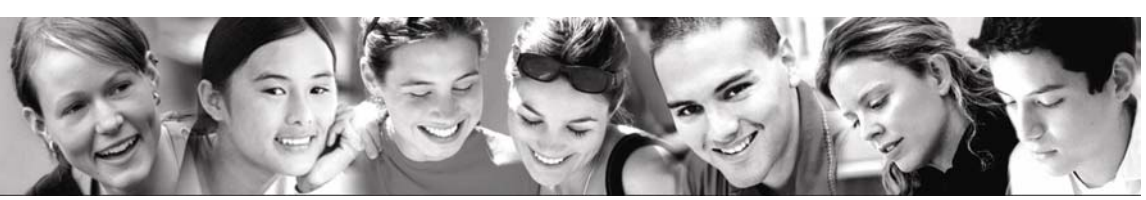

## THE SCHOOL FOR EXCELLENCE (TSFX)

The School For Excellence (**TSFX**) is an independent organisation that provides educational services to Year 11 and 12 students out of school hours. These services include the development and delivery of intense revision courses before examinations, intense weekly tuition classes, study skills lectures, as well as specialised courses that prepare students in advance of each school term.

The educational programs conducted by **TSFX** are widely recognised for providing the highest quality programs in Victoria today. Our programs are the result of more than 16 years of collaborative effort and expertise from dozens of teachers and schools across the state, ensuring the highest possible quality resources and teaching styles for VCE students.

### FREE VCE RESOURCES AT VCEDGE ONLINE

**VCEdge Online** is an educational resource designed to provide students the best opportunities to optimise their Year 11 or 12 scores. **VCEdge Online** members receive over \$300 worth of resources at **no charge**, including:

- Subject notes and course summaries.
- Sample A+ SACS, essays, projects and assignments.
- Trial examinations with worked solutions.
- Weekly study tips and exam advice (in the weeks leading up to the examinations)
- Two **FREE** tickets into an intense examination strategy lecture (valued at \$300!!!).
- Cheat sheets and formula cards.
- Critical VCE updates.
- Free VCE newsletters.
- Information on upcoming educational events.
- And much, much more!!!

**JOIN FREE OF CHARGE AT [WWW.TSFX.COM.AU](http://WWW.TSFX.COM.AU)**

### PRINTING SPECIFICATIONS

Please ensure that the paper size on your printer is selected as **A4** and that you select "**None**" under "Page Scaling".

## SECTION A

### Specific Instructions For Section A

Section A consists of 20 multiple-choice questions. Section A is worth approximately 24% of the marks available. You should spend approximately 20 minutes on this section.

Choose the response that is **correct** or **best answers the question**.

A correct answer is worth 1 mark, an incorrect answer is worth no marks. No mark will be given if more than one answer is shown for any question. Marks will **not** be deducted for incorrect answers. You should attempt every question.

### QUESTION 1

The main reason for the use of catalysts in most industrial processes is to

- A reduce greenhouse gas emissions.
- B reduce the energy requirement for a reaction.
- C reduce waste production.
- D increase the yield of product.

### QUESTION 2

Four bottles containing varying volumes of acid solution were labelled as follows:

Bottle A: 0.50 M Benzoic acid

Bottle B: 0.10 M Ethanoic acid

Bottle C: 0.50 M Boric acid

Bottle D: 0.10 M Hydrocyanic acid

The weakest acid is contained in

- A Bottle A
- B Bottle B
- C Bottle C
- D Bottle D

### QUESTION 3

Which of the following statements is **incorrect**?

- A Reactions with high equilibrium constants will proceed spontaneously.
- B The equilibrium constant will not change if the initial concentrations of reactants or products are changed at constant temperature.
- C The equations  $H_{2(g)} + I_{2(g)} \rightleftharpoons 2HI_{(g)}$  and  $\frac{1}{2}H_{2(g)} + \frac{1}{2}I_{2(g)} \rightleftharpoons HI_{(g)}$  will have different equilibrium constants for a given set of equilibrium concentrations at the same temperature.
- D The equilibrium constant has no bearing on the reaction rate.

### QUESTION 4

The equilibrium constant for the reaction  $NH_{3(aq)} + H_2O_{(l)} \rightleftharpoons NH_{4(aq)}^+ + OH_{(aq)}^-$  is

- A  $[NH_{4(aq)}^+][OH_{(aq)}^-]M^2$
- B  $\frac{[NH_{4(aq)}^+][OH_{(aq)}^-]}{[NH_{3(aq)}]}$
- C  $\frac{[NH_{4(aq)}^+][OH_{(aq)}^-]}{[NH_{3(aq)}][H_2O_{(l)}]}$
- D  $\frac{[NH_{4(aq)}^+][OH_{(aq)}^-]}{[NH_{3(aq)}][H_2O_{(l)}]}M^{-1}$

### QUESTION 5

The graph below shows the changes in concentration at constant temperature for a chemical system that initially only consisted of nitrogen dioxide ( $NO_2$ ).

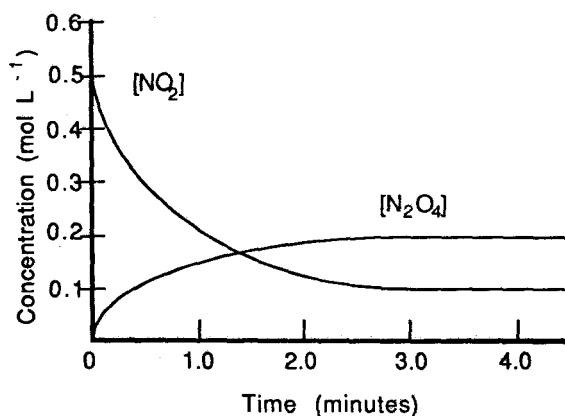
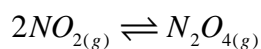

Which of the following statements regarding this system is **correct**?

- |   | <b>Statement 1</b>   | <b>Statement 2</b>   |
|---|--|--|
| A | The reaction reaches equilibrium at about 1.4 minutes and its equilibrium constant is 1.     | The back reaction rate is at its maximum value once equilibrium has been established.        |
| B | The reaction reaches equilibrium at about 3 minutes and its equilibrium constant is about 2. | The back reaction rate is at its lowest value once equilibrium has been established.         |
| C | The forward reaction rate increases as the system approaches equilibrium.                    | The reaction reaches equilibrium at about 3 minutes and its equilibrium constant is about 2. |
| D | The forward reaction rate decreases as the system approaches equilibrium.                    | The reaction reaches equilibrium at about 3 minutes and its equilibrium constant is about 2. |

### QUESTION 6

The reaction below is allowed to reach equilibrium.

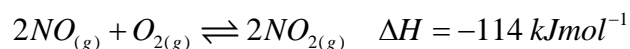

If the temperature is then decreased at constant volume, and the system re-establishes equilibrium,

- A the equilibrium constant will decrease and  $[NO_2]$  will decrease.
- B the equilibrium constant will decrease and  $[NO_2]$  will increase.
- C the equilibrium constant will increase and  $[NO_2]$  will decrease.
- D the equilibrium constant will increase and  $[NO_2]$  will increase.

### QUESTION 7

Consider the following equilibrium mixture:

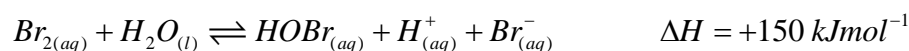

Which one of the following gives two different ways of increasing the equilibrium yield of product?

- A Dilution with water; a decrease in temperature.
- B Adding a drop of concentrated  $HOBr_{(aq)}$ ; a decrease in temperature.
- C Adding a drop of concentrated  $OH_{(aq)}^-$ ; dilution with water
- D Adding a drop of concentrated  $Br_{2(aq)}$ ; a decrease in temperature.

**The following information refers to Questions 8 and 9.**

The pH of pure water is 7.60 at  $5^\circ C$ . The  $K_w$  at this temperature is

### QUESTION 8

- A  $2.52 \times 10^{-8}$
- B  $1.00 \times 10^{-14}$
- C  $6.31 \times 10^{-16}$
- D Cannot be determined from the given information.

### QUESTION 9

The pH of a 0.0500 M NaOH solution at  $5^\circ C$  is

- A 1.3
- B 12.7
- C 13.9
- D Cannot be determined from the given information,

**QUESTION 10**

The specific heat capacity of a substance is

- A the quantity of heat required to boil 1 gram of that substance.
- B the quantity of heat required to melt 1 gram of that substance.
- C the quantity of heat required to increase the temperature of 1 gram of a substance by  $1^{\circ}\text{C}$ .
- D the quantity of heat required to increase the temperature of 1 gram of a substance by  $4.184^{\circ}\text{C}$ .

***The following information relates to Questions 11-13.***

Consider the following fuels: Coal, hydrogen, natural gas and petrol.

**QUESTION 11**

Which fuel releases the greatest amount of energy per gram?

- A Coal
- B Hydrogen
- C Natural gas
- D Petrol

**QUESTION 12**

Which fuel is a major contributor to the formation of acid rain.

- A Coal
- B Hydrogen
- C Natural gas
- D Petrol

**QUESTION 13**

Which fuel does not produce chemical pollutants?

- A Coal
- B Hydrogen
- C Natural gas
- D Petrol

**QUESTION 14**

Consider the equations:

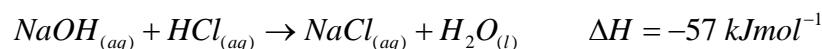
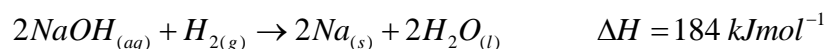

The enthalpy for the reaction between sodium metal and dilute hydrochloric acid is

- A  $-298 \text{ kJmol}^{-1}$
- B  $-241 \text{ kJmol}^{-1}$
- C  $127 \text{ kJmol}^{-1}$
- D  $298 \text{ kJmol}^{-1}$

**QUESTION 15**

Bomb calorimeters may be calibrated by combusting a pure substance with a known heat of combustion. A particular bomb calorimeter was calibrated using 100 mL of pure ethanol (density  $0.789 \text{ g mL}^{-1}$ ). If the temperature rose by  $10.4^\circ \text{C}$  during the combustion of pure ethanol, the calibration factor for the calorimeter would be

- A  $131 \text{ kJ}^\circ \text{C}^{-1}$
- B  $197 \text{ kJ}^\circ \text{C}^{-1}$
- C  $226 \text{ kJ}^\circ \text{C}^{-1}$
- D  $285 \text{ kJ}^\circ \text{C}^{-1}$

**QUESTION 16**

When a drop of  $1 \text{ M } \text{XCl}_{2(aq)}$  is placed on a lead plate, no reaction is observed. When a drop of  $1 \text{ M } \text{YCl}_{3(aq)}$  is placed on a different part on the lead plate, a reaction is observed. The results of these experiments indicates that

- A  $\text{X}$  is a stronger reductant than  $\text{Pb}$  and that  $\text{Y}^{3+}$  is a stronger oxidant than  $\text{Pb}^{2+}$ .
- B  $\text{Pb}$  is a stronger reductant than  $\text{X}$  and that  $\text{Pb}^{2+}$  is a stronger oxidant than  $\text{Y}^{3+}$ .
- C  $\text{X}$  is a stronger oxidant than  $\text{Pb}$  and that  $\text{Y}^{3+}$  is a stronger reductant than  $\text{Pb}^{2+}$ .
- D  $\text{Pb}$  is a stronger oxidant than  $\text{X}$  and that  $\text{Pb}^{2+}$  is a stronger reductant than  $\text{Y}^{3+}$ .



### QUESTION 17

The reaction between a  $1.0\text{ M}$  solution of  $X^{2+}$  and metal  $Y$  at  $25^{\circ}\text{C}$  and  $1\text{ atm}$  pressure is given below.

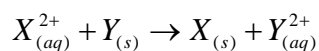

If the EMF for this reaction under the given conditions is  $0.45\text{ V}$  which of the following statements is **incorrect**?

- A The reaction will proceed spontaneously.
- B The given EMF will differ if the concentration of  $X^{2+}$  is increased to  $5.0\text{ M}$ .
- C The reaction is exothermic when the cell is producing electricity.
- D The reaction rate involving a  $5.0\text{ M}$  solution of  $X^{2+}$  will be greater than that observed when a  $1.0\text{ M}$  solution of  $X^{2+}$  is used to produce electricity.

### QUESTION 18

Which of the following does **not** play a role in determining which products are formed during electrolytic procedures?

- A Concentration of ions in solution
- B The nature of the electrodes
- C The temperature
- D The distance between electrodes

### QUESTION 19

The nickel-cadmium rechargeable cell was invented by a Swedish engineer in 1899, and by the middle of the 20<sup>th</sup> century, it was produced on a large scale. The equation representing the reaction during the cells discharge cycle is

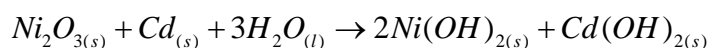

If the reaction occurring at the cathode whilst the cell is discharging is

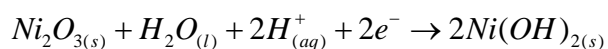

then the reaction occurring at the cathode during the recharging process is

- A  $Cd_{(s)} + 2H_2O_{(l)} \rightarrow Cd(OH)_{2(s)} + 2H_{(aq)}^+ + 2e^-$
- B  $Cd(OH)_{2(s)} + 2H_{(aq)}^+ + 2e^- \rightarrow Cd_{(s)} + 2H_2O_{(l)}$
- C  $2Ni(OH)_{2(s)} \rightarrow Ni_2O_{3(s)} + H_2O_{(l)} + 2H_{(aq)}^+ + 2e^-$
- D  $Ni_2O_{3(s)} + H_2O_{(l)} + 2H_{(aq)}^+ + 2e^- \rightarrow 2Ni(OH)_{2(s)}$

**QUESTION 20**

Three electrolytic cells are connected to an external power source in series as represented in the diagram below. The cells contain  $1.0\text{ M Mg(NO}_3)_2$ ,  $\text{Ni(NO}_3)_2$  and  $\text{AgNO}_3$  respectively and use platinum electrodes.

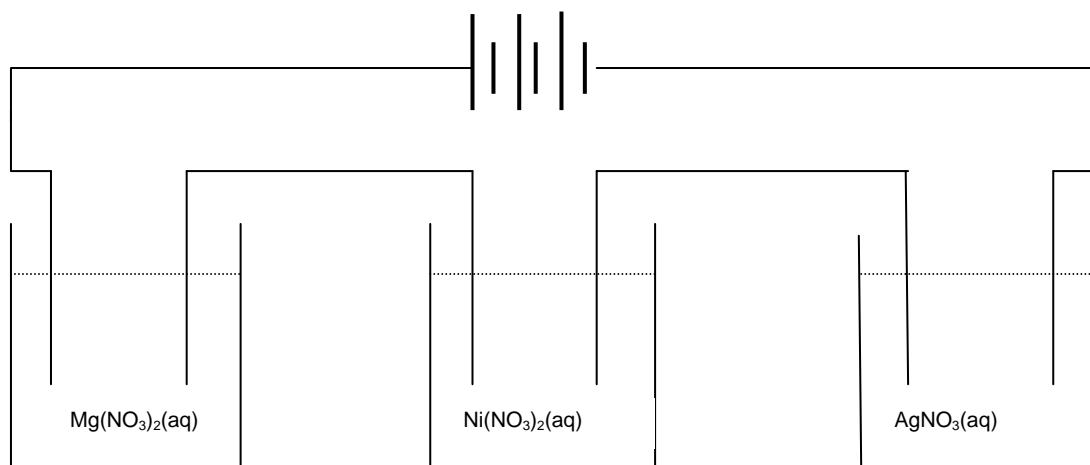

$5.79 \times 10^5$  Coloumbs of electricity passes through each of the cells. The ratio of the masses of the metals produced would be

	<b>Mg</b>	<b>Ni</b>	<b>Ag</b>
A	0	1	4
B	0	2	4
C	1	1	2
D	2	2	1

## SECTION B

### Specific Instructions For Section B

Section B consists of 8 short-answer questions numbered 1 to 7; you must answer all of these questions. This section is worth 62 marks which is approximately 76 per cent of the total available marks. You should spend approximately 70 minutes on this section.

The marks allotted to each question are shown at the end of each question.

Questions must be answered in the spaces provided in this book.

To obtain full marks for your responses you should

- Give simplified answers with an appropriate number of significant figures for all numerical questions; unsimplified answers will not be given full marks.
- Show all working in your answers to numerical questions. No credit will be given for an incorrect answer unless it is accompanied by details of the working.
- Make sure that all chemical equations are balanced and that the formulas for individual substances include an indication of state (for example,  $H_{2(g)}$ ;  $NaCl_{(s)}$ ).

### QUESTION 1

Benzoic acid,  $C_6H_5COOH$  is a weak acid that is partly soluble in water at  $25^\circ C$ .

- a. Calculate the pH of a saturated solution of benzoic acid at  $25^\circ C$  if its concentration is  $0.022 \text{ mol L}^{-1}$  at this temperature.

---

---

---

---

---

---

---

---

---

---

3 marks

- b. 50.00 ml of the saturated acid solution is added to 450.00 ml of water.

Let the pH of the undiluted benzoic acid solution be equal to  $x$ . Which option, A to E, best describes the pH of the diluted solution once the system has re-established equilibrium? Give a reason for your answer.

- A  $pH = x$   
B  $pH = x + 1$   
C  $pH = x - 1$   
D  $pH$  lies between  $x$  and  $x + 1$   
E  $pH$  lies between  $x$  and  $x - 1$

---

---

---

2 marks

Benzoic acid dissolves completely at  $100^\circ C$  as described below:

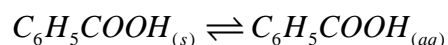

- c. Is the dissolution of benzoic acid exothermic or endothermic? Give a reason for your answer.

---

---

---

---

2 marks

- (d) What pH changes would you observe as a benzoic acid solution was heated? Explain your answer using appropriate equations.

---

---

---

---

2 marks

**Total 9 marks**

## QUESTION 2

Methanol can be prepared industrially according to the following equation:

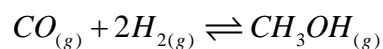

The graph below represents the formation of methanol at various temperatures in the absence of a catalyst.

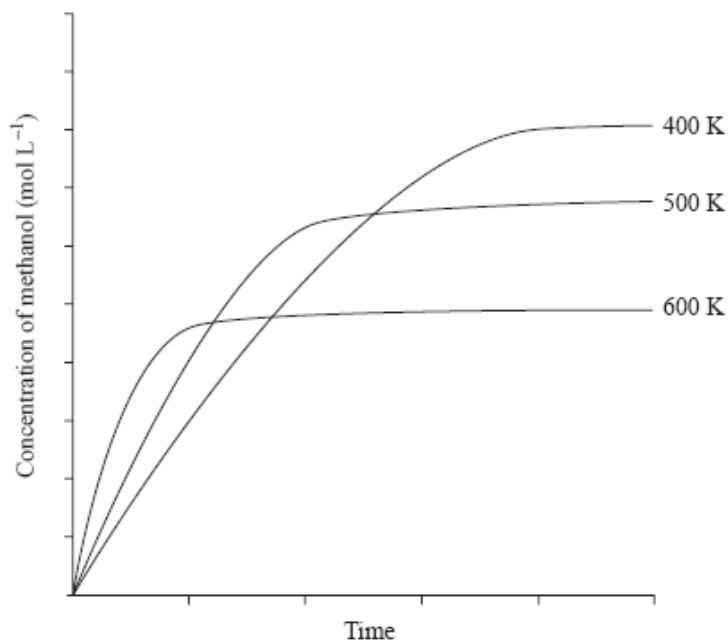

- a. Is the formation of methanol endothermic or exothermic? Give a reason for your answer.

---

---

---

---

2 marks

- b. On the graph above, sketch the graph for the formation of methanol at 500 K in the presence of a catalyst.

2 marks

- c. Equal amounts of carbon monoxide and hydrogen gas are added to an equilibrium mixture at constant temperature and volume. Indicate on the graph the likely changes to the concentration of each gas until the new equilibrium position is established.

Concentration (M)

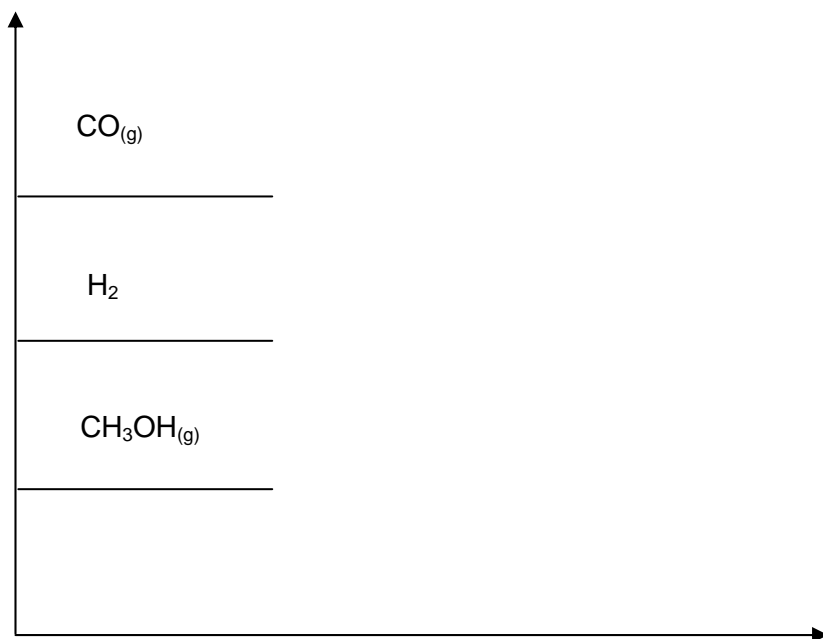

3 marks

- d. 0.40 mole of carbon monoxide gas and 0.50 mole of hydrogen gas are placed in a sealed 2.00 L vessel at constant temperature and allowed to reach equilibrium. At equilibrium, the concentration of hydrogen gas was experimentally determined to be 0.05 M . Calculate the equilibrium constant for this reaction.

---



---



---



---

3 marks

**Total = 10 marks**

### QUESTION 3

A student decides to investigate the effects of changes in pressure on reaction rates and the corresponding equilibrium yields of product.

Three sets of bulbs connected with stopcocks are used in this investigation. Each bulb/stopcock set consists of two glass bulbs of identical volume that are connected by a thin tube with a valve that can be opened or closed. A second tube and valve enables the addition or removal of gas from the bulbs, as illustrated below.

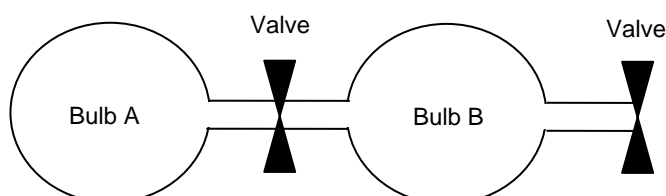

#### Experiment 1:

Equal amounts of  $CO_{(g)}$  and  $Cl_{2(g)}$  are added to Bulb B and the system is allowed to reach equilibrium as described by the reaction  $CO_{(g)} + Cl_{2(g)} \rightleftharpoons COCl_{2(g)}$ .

The stopcock between Bulb A and B is then opened and the system is allowed to re-establish equilibrium, keeping temperature constant.

#### Experiment 2:

Equal amounts of  $CO_{(g)}$  and  $Cl_{2(g)}$  are added to Bulb B and the system is allowed to reach equilibrium as described by the reaction  $CO_{(g)} + Cl_{2(g)} \rightleftharpoons COCl_{2(g)}$ .

$Cl_{2(g)}$  is added to Bulb B at constant temperature and volume, and the system is allowed to re-establish equilibrium.

#### Experiment 3:

Equal amounts of  $CO_{(g)}$  and  $Cl_{2(g)}$  are added to Bulb B and the system is allowed to reach equilibrium as described by the reaction  $CO_{(g)} + Cl_{2(g)} \rightleftharpoons COCl_{2(g)}$ .

Helium gas is added to Bulb B at constant temperature and volume, and the system is allowed to re-establish equilibrium.

- a. Which experiment(s) would result in an increased yield of  $COCl_{2(g)}$ ?

\_\_\_\_\_

1 mark

- b. Which experiment(s) would result in an increased concentration of  $Cl_{2(g)}$ ?

\_\_\_\_\_

1 mark

- c. Once equilibrium has been re-established, which experiment(s) would exhibit the fastest reaction rates? Explain your answer in terms of the collision theory,

---

---

---

---

2 marks

Equilibrium constants for reactions involving gases are often written in terms of the partial pressures of the individual gases rather than concentration.

Let  $p(\text{CO}_{(g)})$  represent the partial pressure of  $\text{CO}_{(g)}$ .

- d. Write the equilibrium constant for the reaction  $\text{CO}_{(g)} + \text{Cl}_{2(g)} \rightleftharpoons \text{COCl}_{2(g)}$  in terms of partial pressures.

---

---

1 mark

- e. The equilibrium constant for this reaction at  $46^\circ\text{C}$  is  $0.66 \text{ atm}$ . If equal amounts of  $\text{CO}_{(g)}$  and  $\text{Cl}_{2(g)}$  are mixed at constant temperature, calculate the equilibrium concentration of  $\text{COCl}_{2(g)}$  if  $p(\text{CO}_{(g)})$  at equilibrium is  $2 \text{ atm}$ .

---

---

---

---

---

2 marks

**Total = 7 marks**



#### QUESTION 4

Choose one chemical from the list below and answer questions **a.** **b.** and **c.**

##### Ammonia

- a.** Ammonia is manufactured using the Haber process. Write the equation describing the reaction that occurs in this process and state whether the forward reaction is endothermic or exothermic.

\_\_\_\_\_

1 mark

- b.** State 1 way apart from the addition of reactant in which the equilibrium yield of product in **a.** can be maximised.

\_\_\_\_\_

1 mark

- c.** Write an equation showing ammonia acting as a reducing agent.

\_\_\_\_\_

1 mark

##### Ethene

- a.** Ethene is primarily produced by the cracking of larger hydrocarbon molecules. Write the equation describing the cracking of decane and state whether the forward reaction is endothermic or exothermic.

\_\_\_\_\_

1 mark

- b.** State 1 way apart from the addition of reactant in which the equilibrium yield of product in **a.** can be maximised.

\_\_\_\_\_

1 mark

- c.** Write an equation showing ethene acting as an oxidising agent.

\_\_\_\_\_

1 mark

### Nitric Acid

- a. Nitric acid is mainly produced in large scale using the **Ostwald** process. Write the equation for the reaction that occurs in the converter during this process and state whether the forward reaction is endothermic or exothermic.

---

1 mark

- b. State 1 way apart from the addition of reactant in which the equilibrium yield of product in **a.** can be maximised.

---

1 mark

- c. Write an equation showing nitric acid acting as an oxidising agent.

---

1 mark

### Sulfuric Acid

- a. Sulfuric acid is mainly produced in large scale using the Contact process. Write the equation for the reaction that occurs in the converter during this process and state whether the forward reaction is endothermic or exothermic.

---

1 mark

- b. State 1 way apart from the addition of reactant in which the equilibrium yield of product in **a.** can be maximised.

---

1 mark

- c. Write an equation showing sulfuric acid acting as a strong oxidant

---

1 mark

**Total = 3 marks**

### QUESTION 5

A galvanic and electrolytic cell were connected as follows.

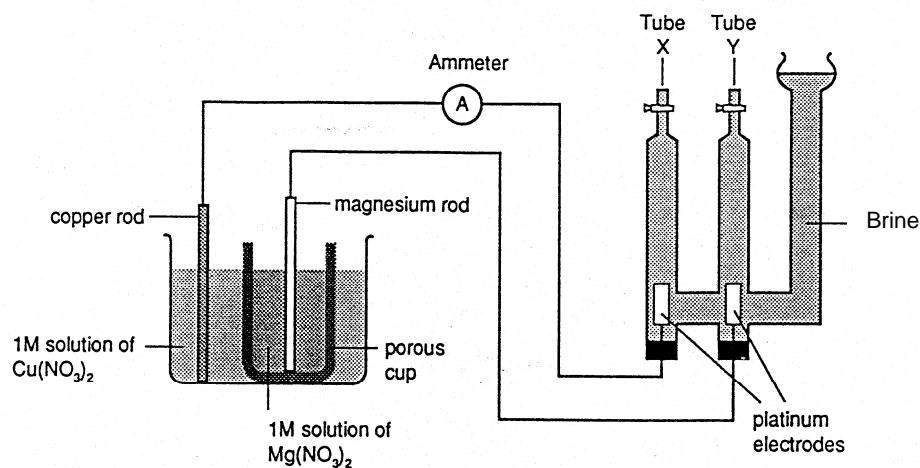

- a. Write the overall equation for the reaction that occurs in the galvanic cell.

---

---

---

---

2 marks

- b. State the polarity of the magnesium electrode in the galvanic cell.

---

1 mark

- c. Which tube in the electrolytic cell represents the cathode?

---

1 mark

- d. After some time bubbles of gas were observed in Tube X. Identify this gas.

---

1 mark

- e. What volume of gas would collect in Tube X at STP if the mass of magnesium in the galvanic cell changed by  $0.100\text{ g}$  during this process?

---

---

---

---

---

---

---

---

---

---

3 marks

**Total = 8 marks**

**QUESTION 6**

20.00 g of hydrated barium hydroxide and 20.00 g of ammonium cyanate are mixed in a solution calorimeter with calibration factor  $200.0 \text{ J / } ^\circ\text{C}$  at  $25^\circ\text{C}$ , and the following reaction occurs.

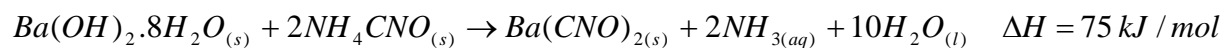

- a. Calculate the energy change (in Joules) that would be observed during the course of this reaction.

---

---

---

---

---

---

---

2 marks

- b. What temperature would be recorded on the thermometer when the reaction is complete?

---

---

---

---

---

---

---

2 marks

- c. The enthalpy profile for the reaction between 20.00 g of hydrated barium hydroxide and 20.00 g of ammonium cyanate is given below.

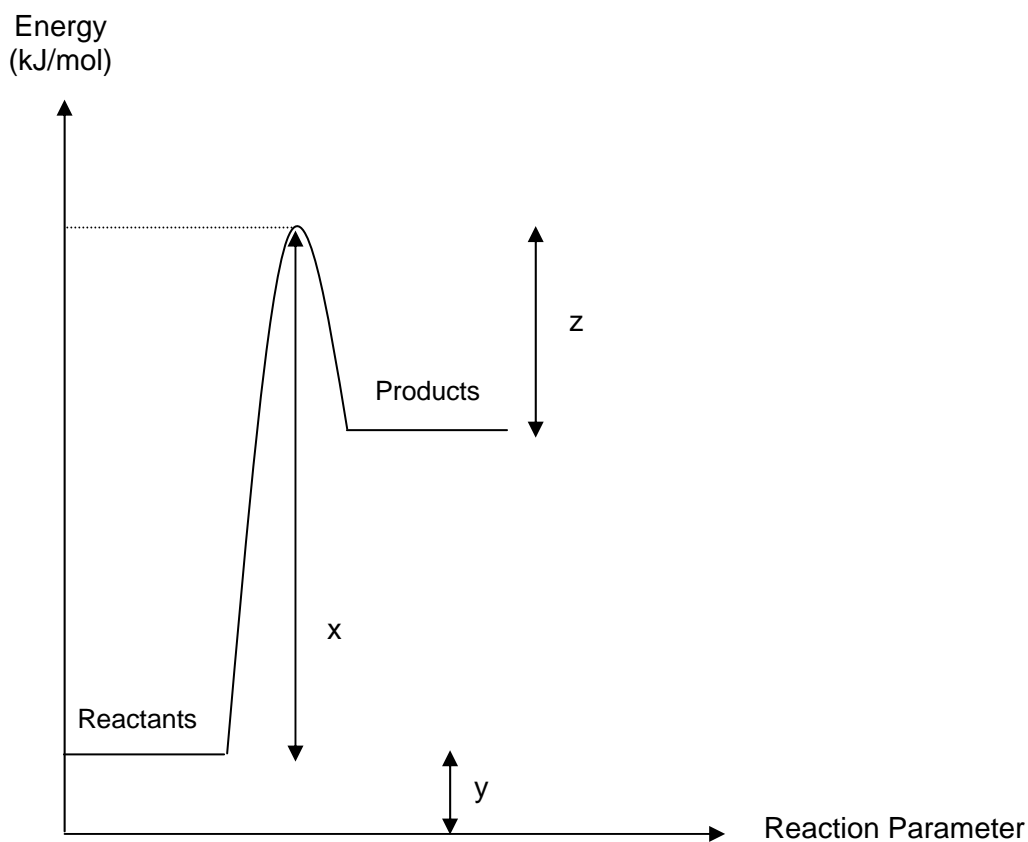

- (i) Which letter(s),  $x$ ,  $y$ ,  $z$ , best describe(s) the  $\Delta H$  for the forward reaction?

---

1 mark

- (ii) State the enthalpy of the products in terms of  $x$ ,  $y$  and/or  $z$ .

---

1 mark

- (iii) State the value of the activation energy for the reverse reaction in terms of  $x$ ,  $y$  and/or  $z$ .

---

1 mark

- (iv) Which values,  $x$ ,  $y$  and/or  $z$  will change upon the addition of a catalyst?

---

1 mark

**Total 8 marks**

**QUESTION 7**

An electrolytic cell is used to reduce Indium, *In*, from a molten salt. A current of 1.55 A was applied for 95.0 minutes and 3.50 g of indium metal was deposited on one of the electrodes.

- a. On which electrode was the metal deposited? Give a reason for your answer.

---

---

1 mark

- b. (i) Calculate the number of Faraday's of charge passed through the cell during this process.

---

---

---

---

2 marks

- (ii) Calculate the amount, in mole, of indium deposited.

---

---

1 mark

- c. Determine the oxidation state of indium in the molten salt.

---

---

---

---

---

---

2 marks

- d. Give a reason as to why this process was conducted using molten indium rather than an aqueous solution.

---

---

---

1 mark

- e. Calculate the energy required for the process if the voltage applied across the 95.0 minutes was  $1.50\text{ V}$ . State your answer in  $\text{kJ}$ .

---

---

---

1 mark

**Total = 8 marks**



## BONUS QUESTION

### QUESTION 8

The combustion of fossil fuels supplies more than 80% of Australia's electricity. The burning of coal in a power station involves a series of energy transformations before generating electricity.

- a. In the space provided below the flowchart, indicate the type of energy transformation that occurs at each stage within the power station.

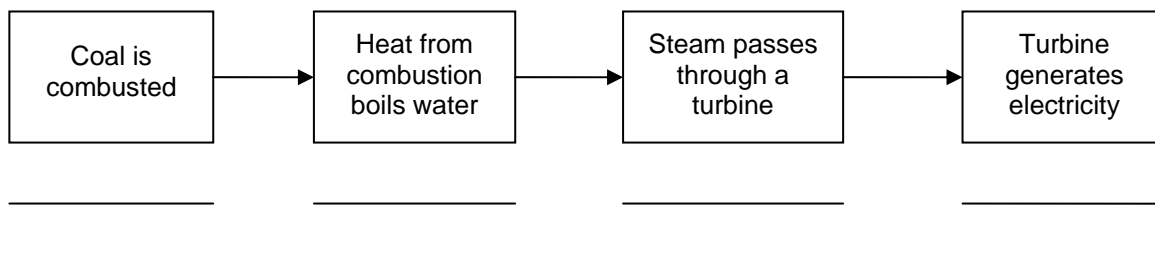

2 marks

- b. The combustion of pure carbon (as graphite) may be represented by the equation



Given that the evaporation of water requires  $44.0 \text{ kJ}$  of energy per mole of water, calculate the amount of energy that would be produced as the result of the combustion of  $10.0 \text{ kg}$  of brown coal, which consists of 70% carbon by mass.

\_\_\_\_\_

\_\_\_\_\_

\_\_\_\_\_

\_\_\_\_\_

\_\_\_\_\_

\_\_\_\_\_

\_\_\_\_\_

\_\_\_\_\_

\_\_\_\_\_

3 marks

- c. Why is the heat of combustion of coal measured in  $\text{kJg}^{-1}$  rather than  $\text{kJmol}^{-1}$ ?

---

---

---

1 mark

- d. Consider the following fuels: Coal, hydrogen, methanol, natural gas and petrol. Which fuel releases the greatest amount of energy per gram? Calculate this value for your chosen fuel.

---

---

---

---

---

---

---

2 marks

**Total = 8 marks**