

Student name

CHEMISTRY

Unit 4

Trial Examination

QUESTION AND ANSWER BOOK

Total writing time: 1 hour 30 minutes

Structure of book

Section	Number of questions	Number of marks
A	20	20
B	9	60
	Total	80

- Students are permitted to bring into the examination room: pens, pencils, highlighters, erasers, sharpeners, rulers, one scientific calculator.
- Students are NOT permitted to bring into the examination room: blank sheets of paper and/or white out liquid/tape, mobile phones and/or any other unauthorised electronic devices.
- A copy of the official VCAA Data Book (printed or photocopied) can be brought into the trial examination.

Materials supplied

- Question and answer book of 16 pages, with a detachable answer sheet for multiple-choice questions inside the front cover.

Instructions

- Detach the answer sheet for multiple-choice questions during reading time.
- Write your **name** in the space provided above on this page and on the answer sheet for multiple-choice questions.
- All written responses should be in English.

At the end of the examination

- Place the answer sheet for multiple-choice questions inside the front cover of this book.
- You may keep your copy of the VCAA Data Book.

SECTION A – Multiple-choice questions**Instructions for Section A**

Answer all questions in pencil on the answer sheet provided for multiple-choice questions.

Choose the response that is **correct** or that **best answers** the question.

A correct answer scores 1, an incorrect answer scores 0.

Marks will **not** be deducted for incorrect answers.

No mark will be given if more than one answer is completed for any question.

Question 1

Catalysts are thought to increase the rate of a chemical reaction by

- A. supplying the energy needed to overcome the activation energy.
- B. increasing the temperature of the reaction.
- C. providing less surface area for the reaction.
- D. providing an alternative reaction pathway with a lower activation energy.

Question 2

A step in the production of sulfuric acid involves the conversion of sulfur dioxide to sulfur trioxide according to the equation:

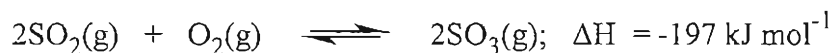

The pressure in the converter where this reaction takes place is maintained at approximately 1 atmosphere. A higher pressure would result in a

- A. higher equilibrium yield and a faster rate of reaction
- B. higher equilibrium yield and a slower rate of reaction
- C. lower equilibrium yield and a faster rate of reaction
- D. lower equilibrium yield and a slower rate of reaction

Question 3

Hydrogen gas has been proposed as a fuel of the future but there are some problems with its use. Which of the following is true for hydrogen gas?

- A. The products of combustion have stronger bonds than hydrogen gas.
- B. It can be made from the reaction of carbon monoxide and steam.
- C. It has a very high energy per gram.
- D. All of the above are true.

Questions 4 and 5 refer to the following list of equations.

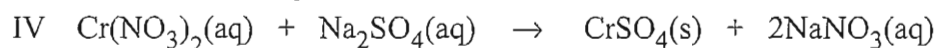
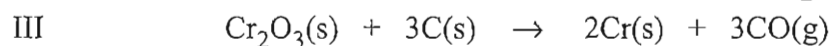
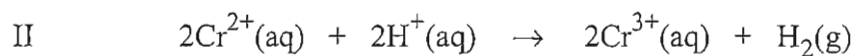
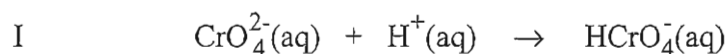

Question 4

Of the equations given, the redox equation(s) is (are)

- A. I only.
- B. I and IV only.
- C. II and III only.
- D. I, II and III only.

Question 5

Of the equations given, the acid/base equation(s) is (are)

- A. I only.
- B. I and II only.
- C. I and III only.
- D. I, II and III only.

Question 6

Pure water is observed to conduct electricity to a small extent. This is because

- A. even pure water will contain a few metal ions.
- B. water self-ionises to produce the hydronium and hydroxide ions.
- C. repeated distillation is still not able to remove all of the dissolved substances.
- D. water molecules are highly polar.

Questions 7 and 8 refer to the following information.

A mixture of ethene gas and hydrogen gas was allowed to react in a sealed, 500 mL flask. The equilibrium that resulted may be represented as

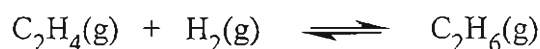

At equilibrium, there was found to be 1.25×10^{-1} mol of $\text{C}_2\text{H}_6(\text{g})$, 7.50×10^{-2} mol of $\text{C}_2\text{H}_4(\text{g})$ and 8.35×10^{-2} mol of $\text{H}_2(\text{g})$ present in the flask.

Question 7

The equilibrium constant for this reaction under these conditions is

- A. 0.0501
- B. 0.100
- C. 9.98
- D. 20.0

Question 8

Which one of the following would result in a change in the value of the equilibrium constant for this reaction?

- A. Increasing the concentration of $\text{C}_2\text{H}_4(\text{g})$
- B. Adding a catalyst.
- C. Decreasing the temperature of the reaction flask.
- D. Increasing the pressure in the flask.

Question 9

The neutralization of an acid and a base may be represented as

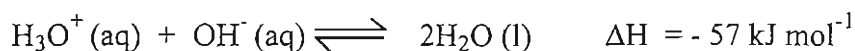

At 25°C , the pH of water is 7.0.

At 0°C , the pH of water will be

- A. unchanged
- B. greater than 7.0
- C. less than 7.0
- D. changed by a factor of 273 / 298

Questions 10 and 11 refer to the following information

The normal pH of human blood is between 7.38 and 7.43 and pH values outside this range can be fatal. The following equilibrium system is involved in maintaining blood pH within this range:

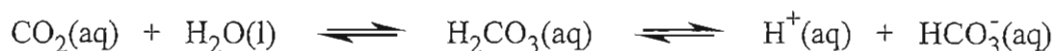
**Question 10**

If carbon dioxide levels were to rise (such as in the case of a pneumonia sufferer) this would

- A. cause a decrease in the concentration of the HCO_3^- ion.
- B. cause the blood pH to fall.
- C. cause an excess of water in the blood and surrounding tissues.
- D. cause the blood pH to rise.

Question 11

In a press release, a pharmaceutical company states that it has developed a drug which acts as a catalyst in the above system. It is claimed that the drug works by “causing an equilibrium shift to the right, thus reducing the amount of CO_2 in the blood of pneumonia sufferers”.

Choose from the following the best statement about this claim.

- A. It is likely to be true because a catalyst always increases the rate of the forward reaction.
- B. It is likely to be true because catalysts work best when the amount of CO_2 present is high.
- C. It cannot be true because a catalyst does not change the position of the equilibrium.
- D. It cannot be true because it would actually cause a shift to the left, thus increasing the amount of CO_2 in the blood.

Question 12

Methanol has been investigated as a fuel for fuel cells but its use does have some problems.

Which of the following is **false** for methanol?

- A. The operation of a fuel cell running on methanol does not produce any greenhouse gas.
- B. It is a liquid at room temperature.
- C. The infrastructure to store, ship and use methanol is in place.
- D. It is a volatile liquid.

Question 13

In an oxygen / methanol fuel cell

- A. the oxidant is methanol and it is oxidised at the anode
- B. the oxidant is methanol and it is reduced at the cathode
- C. the reductant is methanol and it is oxidised at the anode
- D. the reductant is methanol and it is reduced at the cathode

Question 14

An understanding of Le Chatelier's principle is important in the chemical industry. Which prediction can be made using this principle?

- A. The identity of products of a chemical reaction.
- B. The rates of chemical reactions.
- C. The effect of catalysts on the position of equilibrium.
- D. The effect of changes in the concentration of chemical substances in equilibrium.

Questions 15, 16 and 17 refer to the following information

The equilibrium between nitrogen dioxide, NO_2 , and dinitrogen tetroxide, N_2O_4 , at a particular temperature, is described by the equation:

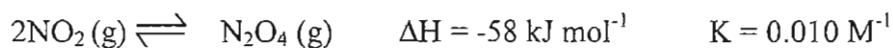
**Question 15**

The equilibrium is rapidly established. When the **volume** of a given amount of an equilibrium mixture of NO_2 and N_2O_4 is **decreased** at constant temperature by compressing a syringe containing the mixture

- A. the overall pressure is decreased.
- B. the ratio $[\text{NO}_2] / [\text{N}_2\text{O}_4]$ is unchanged.
- C. more NO_2 is formed at the expense of N_2O_4 .
- D. more N_2O_4 is formed at the expense of NO_2 .

Question 16

When the temperature of a given equilibrium mixture of NO_2 and N_2O_4 is **increased** at constant volume

- A. NO_2 is formed at the expense of N_2O_4 .
- B. N_2O_4 is formed at the expense of NO_2 .
- C. the rate of reaction decreases.
- D. the ratio $[\text{NO}_2] / [\text{N}_2\text{O}_4]$ is unchanged.

Question 17

Which one of the following statements is correct, when the system is at equilibrium?

- A. $[\text{N}_2\text{O}_4] = \frac{1}{2} \times [\text{NO}_2]$
- B. $[\text{N}_2\text{O}_4] = 0.010 \times [\text{NO}_2]^2$
- C. $[\text{N}_2\text{O}_4] = [\text{NO}_2]^2 / 0.010$
- D. $[\text{N}_2\text{O}_4] + 2[\text{NO}_2] = 0.010$

Question 18

The elements aluminium, magnesium, sodium and chlorine can be produced by the electrolysis of molten compounds. Considering only the electrolysis, which one of the following will require the **highest** quantity of electricity to produce 1.0 g of the element.

- A. Al
- B. Mg
- C. Na
- D. Cl₂

Questions 19 and 20 refer to the following information.

A solution containing a mixture of 1.0 M KNO₃, 1.0 M Zn(NO₃)₂ and 1.0 M Cu(NO₃)₂ is electrolysed using platinum electrodes. The potential is increased in steps of 1.0 volt for 30 minutes until eventually only gaseous products are observed from both electrodes.

Question 19

The electrolytic process was stopped and the coating on the cathode examined. The materials coated onto the electrode from the platinum core outwards will be

- A. copper followed by zinc
- B. copper, zinc and then potassium
- C. copper only
- D. potassium only

Question 20

A gaseous product was

- A. hydrogen, H₂, produced at the anode
- B. oxygen, O₂, produced at the anode
- C. nitrogen, N₂, produced at the cathode
- D. NO₂ gas produced at the cathode.

END OF SECTION A

SECTION B – Short answer questions**Instructions for Section B**

Answer **all** questions in the spaces provided.

To obtain full marks for your responses you should

- give simplified answers with an appropriate number of significant figures for all numerical questions; unsimplified answers will not be given full marks.
- show all working in your answers to numerical questions. No credit will be given for an incorrect answer unless it is accompanied by details of the working.
- make sure chemical equations are balanced and that the formulas for individual substances include an indication of state; for example, $\text{H}_2(\text{g})$; $\text{NaCl}(\text{s})$

Question 1

When chlorine is bubbled into cold, dilute sodium hydroxide, the following equilibrium is established



- a. Use oxidation numbers to clearly demonstrate why this is a redox reaction.

2 marks

- b. Identify the reducing agent in the reverse direction of the equilibrium. Explain your answer.

2 marks

- c. If more chlorine was added to the equilibrium mixture, what would happen to the pH of the mixture. Explain your answer.

2 marks

Total 6 marks

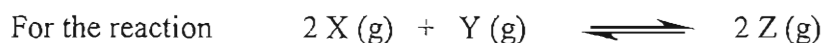
Question 2

The equilibrium constant, K_c , is equal to 4.0 at a particular temperature.
2.0 mol of X, 2.0 mol of Y and 2.0 mol of Z are introduced into a 1.0 L flask.

- a. Write an expression for the equilibrium constant, K_c

1 mark

- b. Give the unit in which K_c is expressed.

1 mark

- c. Prove that the mixture is not at equilibrium.

2 marks

- d. Determine the volume of the container for this particular mixture to be at equilibrium.

2 marks

- e. If the volume of the equilibrium mixture was suddenly doubled, what effect would this have on the amount of reactant Y and the concentration of reactant Y? Explain your answer.

3 marks

Total 9 marks

Question 3

Ethanol is produced from α -glucose, $C_6H_{12}O_6$, by fermentation. Carbon dioxide is the only other product formed.

- a. Write a balanced equation for the fermentation of α -glucose.

1 mark

- b. Write the half equations (assume acidic media) for the

i. oxidation process

ii. reduction process

1 + 1 = 2 marks

- c. A large-scale trial fermentation experiment was carried out in an insulated stainless steel vat. 11.5 kg of glucose, a suitable yeast and water were added to the vat to make the volume up to 100 L of solution. The temperature was monitored over time and was found to rise from 20.0 °C to a steady 30.5 °C.

- i. Calculate the minimum heat energy, in MJ, released by the fermentation process. Assume that the density of the reaction mixture is 1.0 g mL⁻¹.

- ii. Use your value calculated in part c. i. to determine the heat of reaction for the fermentation of glucose, in kJ mol⁻¹.

1 + 2 = 3 marks

Total 6 marks

Question 4

A block of nickel and a block of copper are joined together and then the combined block is placed in a solution of 1.0 M HCl (aq) at 25 °C. It was observed that bubbles of gas are only evolved from the surface of the copper. However if the two blocks are separated and placed in the same acid at 25 °C, the bubbles only appear on the nickel surface.

Explain these observations and including half-equations to support your explanations.

Total 5 marks

Question 5

Lactic acid $\text{CH}_3\text{CH}(\text{OH})\text{COOH}$ is a waste product that accumulates in muscle tissue during exertion, leading to feelings of fatigue and pain. Lactic acid is found to be 3.7% ionised in a 0.0900 M aqueous solution at a particular temperature.

- a. Write the equation for the reaction of lactic acid and water.

1 mark

- b. Write a general expression for the K_a of lactic acid.

1 mark

- c. Calculate the K_a for this acid

4 marks

- d. Some people administer sodium hydrogencarbonate in a 'milkshake' to racing animals. It is thought that this ion decreases the build up of lactic acid in the animal's muscles sustaining performance. Write an ionic equation to show how the lactic acid is neutralised.

1 mark

Total 7 marks

Question 6

The lead – acid accumulator, or car battery, uses a redox reaction to produce a steady voltage of around 12 volts. The battery is composed of six cells that are each made up of a lead electrode grid plate and a lead (IV) oxide electrode, PbO_2 , in a sulfuric acid solution. The overall equation for the reaction occurring in the cell can be written as

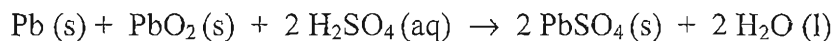

- a. Write the
- oxidation half-equation for the reaction occurring.

- reduction half-equation for the reaction occurring.

1 + 1 = 2 marks

- b. Which electrode is the cathode in each cell?

1 mark

- c. Which ions in the electrolyte of the battery would have a net migration towards the positive electrode?

1 mark

- d. The theoretical cell voltage can be calculated to be 2.0 V. However the actual voltage is about 2.2 V. Suggest a reason for this difference.

1 mark

- e. Write the equation occurring at the negative terminal of the battery when the battery is being recharged.

1 mark

- f. Explain why the density of the acid in the battery can indicate how ‘charged’ the battery is.

1 mark

Total 7 marks

Question 7

0.10 M solutions of hydrochloric acid, ethanoic acid and sulfuric acid were prepared. The pH of the ethanoic acid solution was found to be 3.4.

- a. Determine the pH of the hydrochloric acid solution.

1 mark

- b. Compare the pH of the sulfuric acid to the pH of the hydrochloric acid solution. Explain why their pH values are different. (No calculations are necessary).

1 mark

- c. Explain why ethanoic acid has a higher pH than the hydrochloric acid solution.

1 mark

- d. The solutions of ethanoic acid and hydrochloric acid are each diluted with distilled water by adding 10 mL of the 0.10 M acid to make 1.0 L of diluted acid. Which solution will undergo the greatest pH change? Explain your answer.

2 marks

Total 5 marks

Question 8

Hydrogen and methanol are fuels used to power some motor vehicles.

- a. i. At one electrode of the fuel cell, hydrogen gas reacts to form hydrogen ions, as shown in the equation:

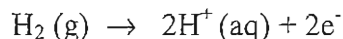

Identify this electrode as the anode or the cathode, and give a reason for your choice.

- ii. Hydrogen for use in a fuel cell can be produced by the electrolysis of water. State the energy change that takes place during electrolysis.
-

2 + 1 = 3 marks

- b. Hydrogen can also be produced by the breakdown of methanol in a steam reformer. The breakdown of methanol to hydrogen occurs in two stages, as shown in the reactions below:



Write an equation (no states required) for the overall reaction for the production of hydrogen.

1 mark

- c. i. Complete the energy data for hydrogen and methanol shown in the table below:

Fuel	Energy per gram (kJ g^{-1})
hydrogen	
methanol	

- ii. Using the data in the table, state which of the two fuels would be more efficient to used in a motor vehicle. Explain your answer.
-
-

2 + 1 = 3 marks

- d. One problem with the use of methanol as a fuel is its high solubility in water. Explain why methanol is highly soluble in water.

2 marks

Total 9 marks

Question 9

Many industrial processes result in the accumulation of deposits in reaction chambers. To clean these chambers a powerful oxidant, such as fluorine gas, F_2 , is required. A safe and cheap method of generating F_2 on-site uses anhydrous hydrogen fluoride, HF.

An electrolytic cell used for the on-site production of F_2 is shown below.

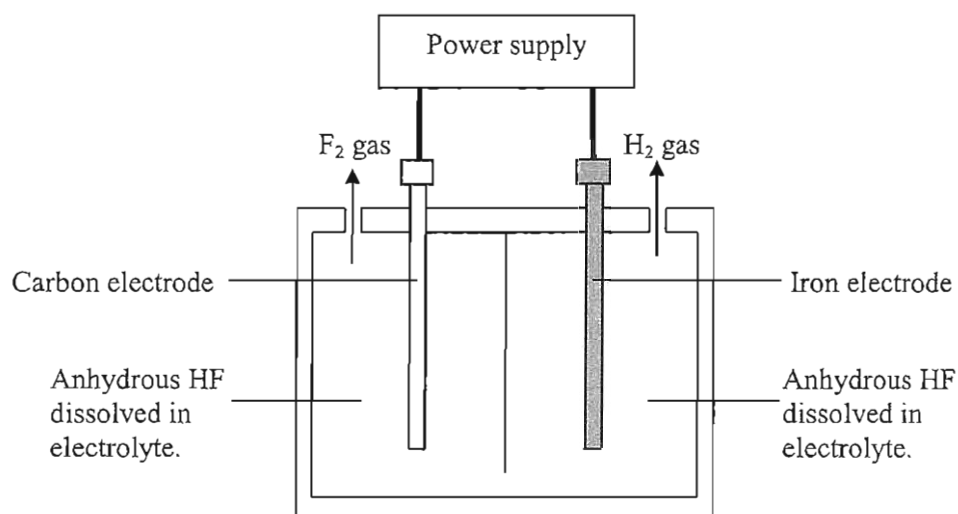

- a. Indicate which of the electrodes is the cathode.

1 mark

- b. Write the half equations for the reactions expected at the:

i. iron electrode:

ii. carbon electrode:

1 + 1 = 2 marks

- c. Anhydrous hydrogen fluoride is used rather than an aqueous solution of HF. Suggest a reason for this **and** include a relevant chemical equation to assist in your response.

2 marks

- d. Iron electrodes are cheaper and better electrical conductors than carbon electrodes. Explain why a carbon electrode and not an iron electrode is used in the chamber where fluorine gas is produced.

1 mark

- e. In a pilot plant a current of 10.5 A was passed through a cell for 10 minutes with an efficiency of 90 percent.

- i. Calculate the amount, in mol, of fluorine gas produced.

- ii. Determine the volume this amount of fluorine gas would occupy at SLC.

4 + 1 = 5 marks

Total 11 marks

END OF EXAMINATION

STAV Publishing

2009

CHEMISTRY

Unit 4 Trial Examination

MULTIPLE CHOICE ANSWER SHEET

STUDENT NAME:	
------------------	--

INSTRUCTIONS:

USE PENCIL ONLY

- Write your name in the space provided above.
- Use a **PENCIL** for **ALL** entries.
- If you make a mistake, **ERASE** it – **DO NOT** cross it out.
- Marks will **NOT** be deducted for incorrect answers.
- **NO MARK** will be given if more than **ONE** answer is completed for any question.
- Mark your answer by **SHADING** the letter of your choice.

	ONE ANSWER PER LINE		ONE ANSWER PER LINE
1	<input type="checkbox"/> A <input type="checkbox"/> B <input type="checkbox"/> C <input type="checkbox"/> D	11	<input type="checkbox"/> A <input type="checkbox"/> B <input type="checkbox"/> C <input type="checkbox"/> D
2	<input type="checkbox"/> A <input type="checkbox"/> B <input type="checkbox"/> C <input type="checkbox"/> D	12	<input type="checkbox"/> A <input type="checkbox"/> B <input type="checkbox"/> C <input type="checkbox"/> D
3	<input type="checkbox"/> A <input type="checkbox"/> B <input type="checkbox"/> C <input type="checkbox"/> D	13	<input type="checkbox"/> A <input type="checkbox"/> B <input type="checkbox"/> C <input type="checkbox"/> D
4	<input type="checkbox"/> A <input type="checkbox"/> B <input type="checkbox"/> C <input type="checkbox"/> D	14	<input type="checkbox"/> A <input type="checkbox"/> B <input type="checkbox"/> C <input type="checkbox"/> D
5	<input type="checkbox"/> A <input type="checkbox"/> B <input type="checkbox"/> C <input type="checkbox"/> D	15	<input type="checkbox"/> A <input type="checkbox"/> B <input type="checkbox"/> C <input type="checkbox"/> D
6	<input type="checkbox"/> A <input type="checkbox"/> B <input type="checkbox"/> C <input type="checkbox"/> D	16	<input type="checkbox"/> A <input type="checkbox"/> B <input type="checkbox"/> C <input type="checkbox"/> D
7	<input type="checkbox"/> A <input type="checkbox"/> B <input type="checkbox"/> C <input type="checkbox"/> D	17	<input type="checkbox"/> A <input type="checkbox"/> B <input type="checkbox"/> C <input type="checkbox"/> D
8	<input type="checkbox"/> A <input type="checkbox"/> B <input type="checkbox"/> C <input type="checkbox"/> D	18	<input type="checkbox"/> A <input type="checkbox"/> B <input type="checkbox"/> C <input type="checkbox"/> D
9	<input type="checkbox"/> A <input type="checkbox"/> B <input type="checkbox"/> C <input type="checkbox"/> D	19	<input type="checkbox"/> A <input type="checkbox"/> B <input type="checkbox"/> C <input type="checkbox"/> D
10	<input type="checkbox"/> A <input type="checkbox"/> B <input type="checkbox"/> C <input type="checkbox"/> D	20	<input type="checkbox"/> A <input type="checkbox"/> B <input type="checkbox"/> C <input type="checkbox"/> D