

# 2021 VCE Biology Trial Examination



**Kilbaha Education**

Quality educational content

**Kilbaha Education**  
PO Box 2227  
Kew Vic 3101  
Australia

**Tel: (03) 9018 5376**

[kilbaha@gmail.com](mailto:kilbaha@gmail.com)  
<https://kilbaha.com.au>

*All publications from Kilbaha Education are digital and are supplied to the purchasing school in both WORD and PDF formats with a school site licence to reproduce for students in both print and electronic formats.*



# Kilbaha Education

Quality educational content

<b>Kilbaha Education (Est. 1978) (ABN 47 065 111 373)</b> <b>PO Box 2227</b> <b>Kew Vic 3101</b> <b>Australia</b>	<b>Tel: +613 9018 5376</b> <b>Email: <a href="mailto:kilbaha@gmail.com">kilbaha@gmail.com</a></b> <b>Web: <a href="https://kilbaha.com.au">https://kilbaha.com.au</a></b>
--	---

## IMPORTANT COPYRIGHT NOTICE FOR KILBAHA PUBLICATIONS

- (1) The material is copyright. Subject to statutory exception and to the provisions of the relevant collective licensing agreements, no reproduction of any part may take place without the written permission of Kilbaha Pty Ltd.
- (2) The contents of these works are copyrighted. Unauthorised copying of any part of these works is illegal and detrimental to the interests of the author(s).
- (3) For authorised copying within Australia please check that your institution has a licence from <https://www.copyright.com.au> This permits the copying of small parts of the material, in limited quantities, within the conditions set out in the licence.
- (4) All pages of Kilbaha files must be counted in Copyright Agency Limited (CAL) surveys.
- (5) Kilbaha files must **not** be uploaded to the Internet.
- (6) Kilbaha files may be placed on a password protected school Intranet.

**Kilbaha educational content has no official status and is not endorsed by any State or Federal Government Education Authority.**

While every care has been taken, no guarantee is given that the content is free from error. Please contact us if you believe you have found an error.

### **CAUTION NEEDED!**

All Web Links when created linked to appropriate Web Sites. Teachers and parents must always check links before using them with students to ensure that students are protected from unsuitable Web Content. Kilbaha Education is not responsible for links that have been changed in its publications or links that have been redirected.

**STUDENT NUMBER**

Letter

Figures										
Words										

**BIOLOGY**

**Trial Written Examination**

Reading time: 15 minutes

Writing time: 2 hours 30 minutes

**QUESTION AND ANSWER BOOK**

**Structure of book**

<i>Section</i>	<i>Number of questions</i>	<i>Number of questions to be answered</i>	<i>Number of marks</i>
A	40	40	40
B	11	11	80
			Total 120

- Students are permitted to bring into the examination room: pens, pencils, highlighters, erasers, sharpeners and rulers.
- Students are NOT permitted to bring into the examination room: blank sheets of paper and/or white out liquid/tape.
- No calculator is allowed in this examination.

**Materials supplied**

- Question and answer book of 29 pages.
- Answer sheet for multiple-choice questions.

**Instructions**

- Write your **student number** in the space provided above on this page.
- Check that your **name** and **student number** as printed on your answer sheet for multiple-choice questions are correct, **and** sign your name in the space provided to verify this.
- All written responses must be in English.

**At the end of the examination**

- Place the answer sheet for multiple-choice questions inside the front cover of this book.

**Students are NOT permitted to bring mobile phones and/or any other unauthorised electronic devices into the examination room.**

# VCE BIOLOGY 2021

## Trial Written Examination

### MULTIPLE-CHOICE ANSWER SHEET

Student Name \_\_\_\_\_

Student Number \_\_\_\_\_

Signature \_\_\_\_\_

If your name or number on this sheet is incorrect, notify the Supervisor.  
Use a **PENCIL** for **ALL** entries. For each question, shade the box that indicates your answer.  
All answers must be completed like **THIS** example.

A	<input checked="" type="checkbox"/>	C	D
---	-------------------------------------	---	---

Marks will **NOT** be deducted for incorrect answers.  
**NO MARK** will be given if more than **ONE** answer is completed for any question.  
If you make a mistake, **ERASE** the incorrect answer. **DO NOT** cross it out.

**ONE ANSWER PER LINE**

**ONE ANSWER PER LINE**

1.	A	B	C	D	21.	A	B	C	D
2.	A	B	C	D	22.	A	B	C	D
3.	A	B	C	D	23.	A	B	C	D
4.	A	B	C	D	24.	A	B	C	D
5.	A	B	C	D	25.	A	B	C	D
6.	A	B	C	D	26.	A	B	C	D
7.	A	B	C	D	27.	A	B	C	D
8.	A	B	C	D	28.	A	B	C	D
9.	A	B	C	D	29.	A	B	C	D
10.	A	B	C	D	30.	A	B	C	D
11.	A	B	C	D	31.	A	B	C	D
12.	A	B	C	D	32.	A	B	C	D
13.	A	B	C	D	33.	A	B	C	D
14.	A	B	C	D	34.	A	B	C	D
15.	A	B	C	D	35.	A	B	C	D
16.	A	B	C	D	36.	A	B	C	D
17.	A	B	C	D	37.	A	B	C	D
18.	A	B	C	D	38.	A	B	C	D
19.	A	B	C	D	39.	A	B	C	D
20.	A	B	C	D	40.	A	B	C	D

**SECTION A – Multiple-choice questions**

Answer **all** questions in pencil on the answer sheet provided for multiple-choice questions.

Choose the response that is **correct** for the question.

A correct answer scores 1, an incorrect answer scores 0.

Marks will **not** be deducted for incorrect answers.

No marks will be given if more than one answer is completed for any question.

**Question 1**

A membrane could be thought of as

- A. A single layer of phospholipids with the polar phosphate heads facing the external environment
- B. A double layer of phospholipids with the polar fatty acid tails facing each other and the non-polar phosphate heads facing away from each other
- C. A combination of protein, cholesterol and phospholipids that interact with each other in a similar way to chemicals mixing in water
- D. A double layer of phospholipids with the non-polar fatty acid tails facing each other and the polar phosphate heads facing away from each other

**Question 2**

The following picture is a representation of a plant cell. Structures 1 to 15 represent cellular components that all play a role in the functioning of the cell

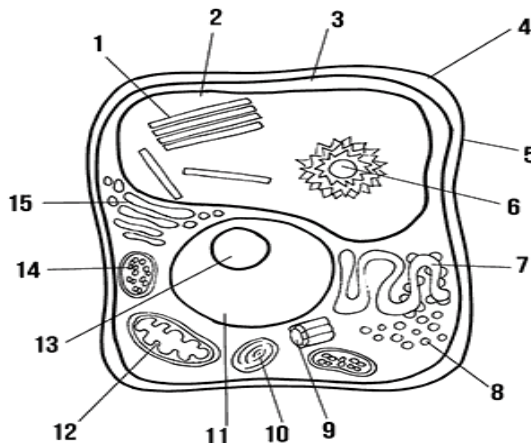

Diagram adapted from: <https://superstarworksheets.com/science-worksheets/plant-cell-worksheets/>

If this cell was to manufacture and secrete a protein the organelles directly involved would be

- A. 3, 7 and 10
- B. 7 and 15
- C. 8 and 15
- D. 11, 12 and 13

**Question 3**

Diagram modified from: <http://www.mun.ca/biology/desmid/brian/BIOL2060/BIOL2060-04/CB04.html>

The diagrams above collectively provide evidence for

- A. The fluid mosaic model theory
- B. The endosymbiotic theory
- C. The exocytosis of organelles
- D. Multicellular evolution

**Question 4**

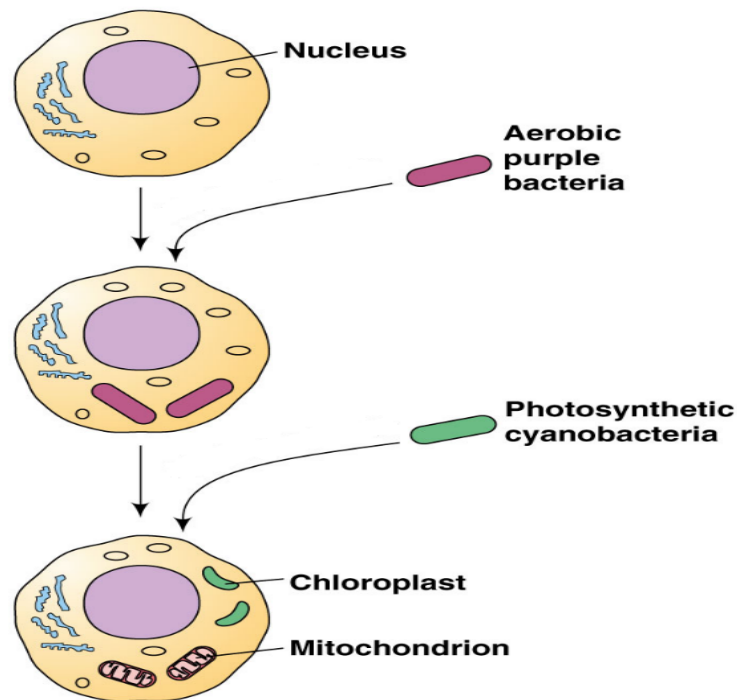
The amino acid leucine joins with the amino acid alanine at the ribosome in an endergonic reaction producing water. This type of reaction is

- A. An example of condensation polymerisation
- B. An example a hydrolysis reaction
- C. An example of a catabolic reaction
- D. Also called transcription

**Question 5**

Which of the following biomolecules would be a nucleic acid?

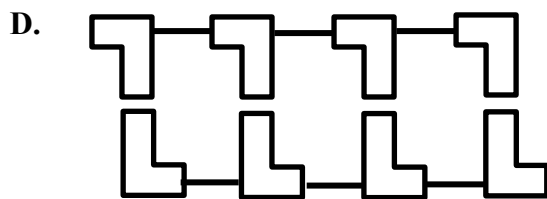
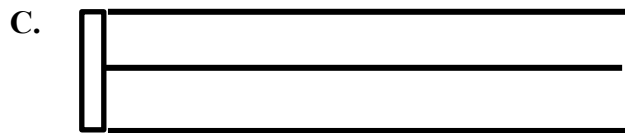
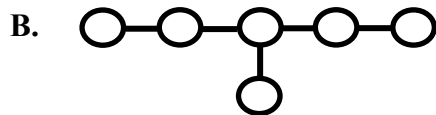
**Question 6**

Degeneracy in the genetic code means that

- A. The codons (ACU, ACC, ACA, ACG) all code for the amino acid threonine
- B. Several amino acids can have the same codon
- C. Introns are removed from pre mRNA prior to translation
- D. As mRNA is being fed into the ribosome, the methylated cap binds first

The next 3 questions refer to the following diagram

The labels 1 to 4 represent an antibody. The labels 1 to 4 represent different locations on the molecule

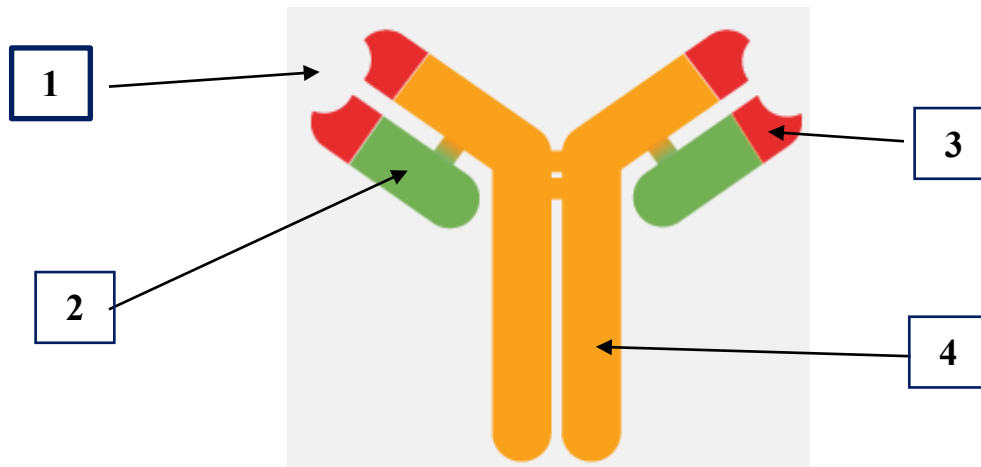

Diagram from: <https://rockland-inc.com/antibodies.aspx>

### Question 7

The heavy chain is

- A. 1
- B. 2
- C. 3
- D. 4

### Question 8

The variable region is

- A. 1
- B. 2
- C. 3
- D. 4

### Question 9

A cell that produces these molecules is a

- A. B Plasma cell
- B. Helper T cell
- C. B Memory cell
- D. Mast cell



The next 2 questions refer to the following biochemical pathway

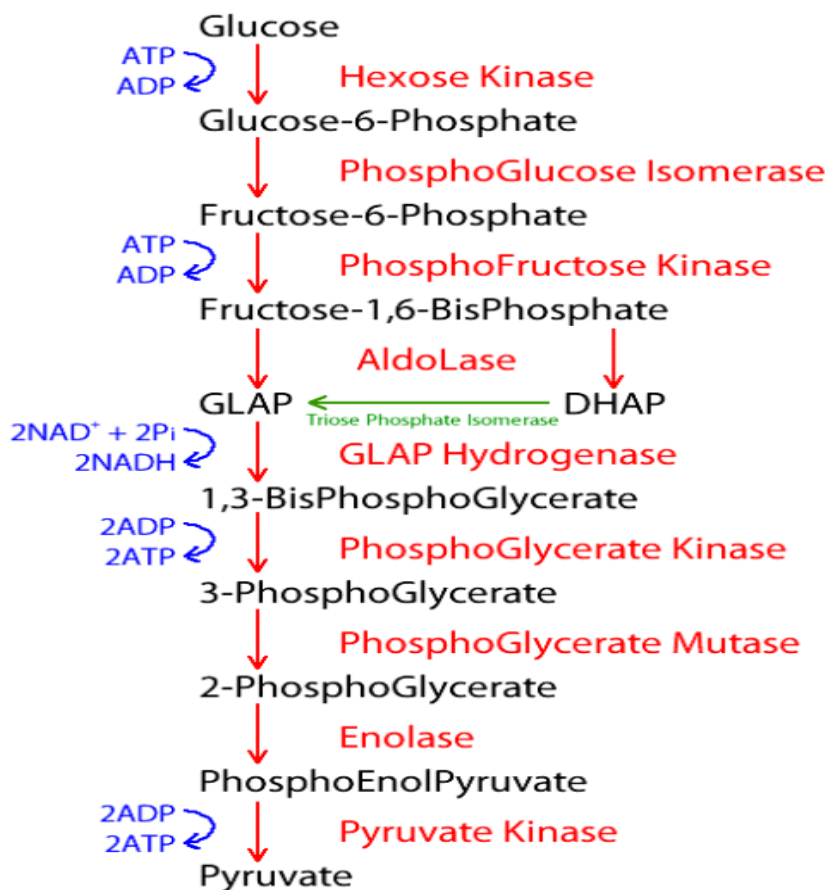

Diagram modified from: <https://sachabiochem0001.wordpress.com/2013/03/23/week-9-reflection-glycolysis/>

### Question 10

An enzyme involved in the biochemical pathway illustrated above would be

- A. PhosphoGlycerate
- B. NADH
- C. Used up
- D. Enolase

### Question 11

The input(s) of this chemical reaction is/are

- A. Glucose, ATP and NADH
- B. Glucose, 2ADP, 2NAD<sup>+</sup> and 2Pi
- C. Pyruvate, Glucose, 2ATP and 2NADH
- D. Pyruvate, 2ADP, 2NAD<sup>+</sup> and 2Pi

**Question 12**

Outputs for the electron transport chain include

- A. ATP and NADH
- B. ADP, Pi and NAD
- C. ATP, NAD and H<sub>2</sub>O
- D. ADP, Pi, NADH and O<sub>2</sub>

**Question 13**

Photosynthesis includes

- A. The light reaction in the stroma and the light independent reaction in the grana
- B. The light reaction in the matrix and the light independent reaction in the stroma
- C. The light reaction in the grana and the light independent reaction in the cytosol
- D. The light reaction in the grana and the light independent reaction in the stroma

**Question 14**

Isolation of gland cells from herbivorous moths can lead to the extraction of sufficient quantities of a chemical that can be used as a type of insecticide. The chemicals can be loaded into traps that are hung from crop trees. The idea is the moths are attracted to the chemical in the traps, rather than eating crop leaves. This type of protection is as a result of chemicals called

- A. Pheromones
- B. Neurotransmitters
- C. Plant growth regulators
- D. Cytokines

**Question 15**

Diagram modified from:

[https://bio.libretexts.org/Bookshelves/Ancillary\\_Materials/Worksheets/Biology\\_Tutorials/Signal\\_Transduction](https://bio.libretexts.org/Bookshelves/Ancillary_Materials/Worksheets/Biology_Tutorials/Signal_Transduction)

The labels 1, 2 and 3 on the diagram above should be labelled respectively as

- A. Response, transduction and reception
- B. Stimulus, transduction and response
- C. Transduction, response and reception
- D. Reception, transduction and response

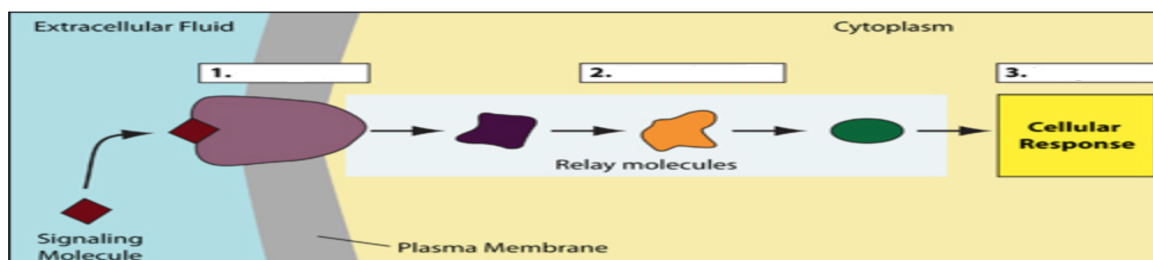
**Question 16**

The diagram below shows several examples of pathogens or pathogenic agents

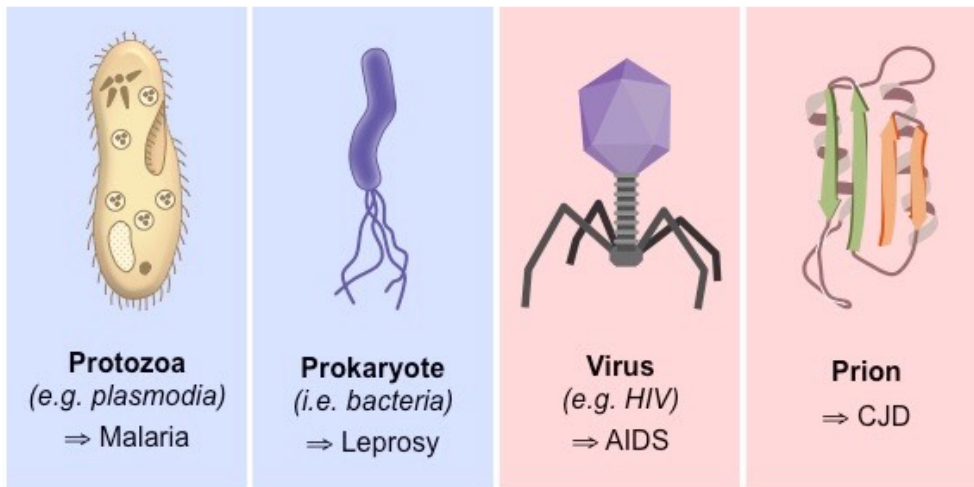

Diagram from:

<https://ib.bioninja.com.au/standard-level/topic-6-human-physiology/63-defence-against-infectio/pathogens.html>

The example that is capable of reproduction but is also categorized as non-cellular is

- A. Malaria
- B. Leprosy
- C. HIV
- D. CJD

**Question 17**

Thunderstorm asthma can place more people at risk of asthma symptoms compared to the number of people who suffer asthma regardless of the climatic conditions. The factor(s) that stimulate(s) an asthmatic response could be regarded as

- A. Non self
- B. Allergenic
- C. Antigenic
- D. All the above

**Question 18**

Lysozyme is an enzyme secreted with tears, milk and saliva that functions as an antimicrobial agent by cleaving the peptidoglycan component of bacterial cell walls, ultimately leading to cell death. This a form of

- A. A physical barrier
- B. A microbiotic barrier
- C. A chemical barrier
- D. A non-specific barrier

The next 2 questions refer to the following diagram

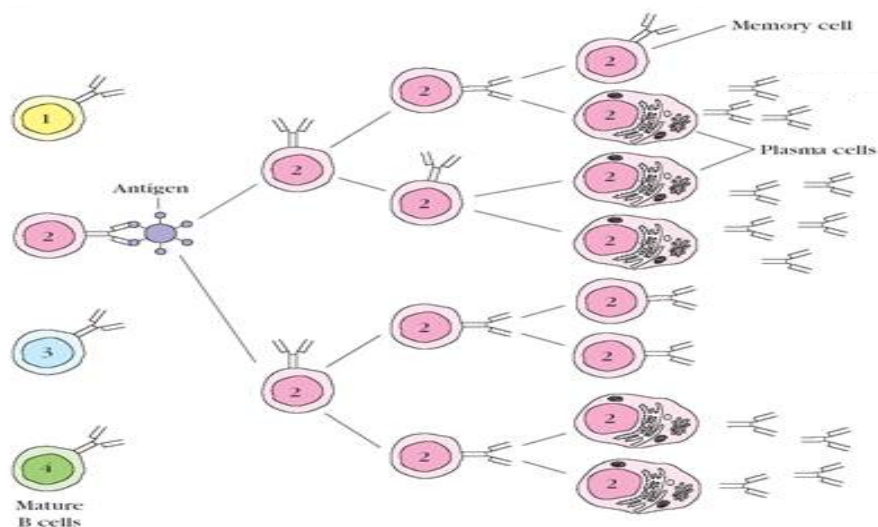

Diagram from: <https://poznayka.org/s35707t1.html>

### Question 19

The location of the cellular response depicted in the diagram is

- A. The bone marrow
- B. The thymus
- C. The lymphatic ducts
- D. The lymph nodes

### Question 20

The reason there are different types of mature B cells (as illustrated by cells 1 to 4) is primarily due to

- A. Clonal expansion
- B. Alternative splicing
- C. Clonal selection
- D. Differentiation

### Question 21

An appropriate immune response stimulated by an event is outlined by

	Event	Response	Type
A.	Inhaling COVID-19	Production of memory cells	Artificial and active
B.	Funnel web spider bite	Production of helper T cells	Natural and passive
C.	Exchange of material across the placenta	None	Natural and passive
D.	Receiving the flu vaccine	Production of Plasma cells	Artificial and active

**Question 22**

Changes in DNA can occasionally lead to a change in phenotype. The diagram below illustrates several different types of mutations

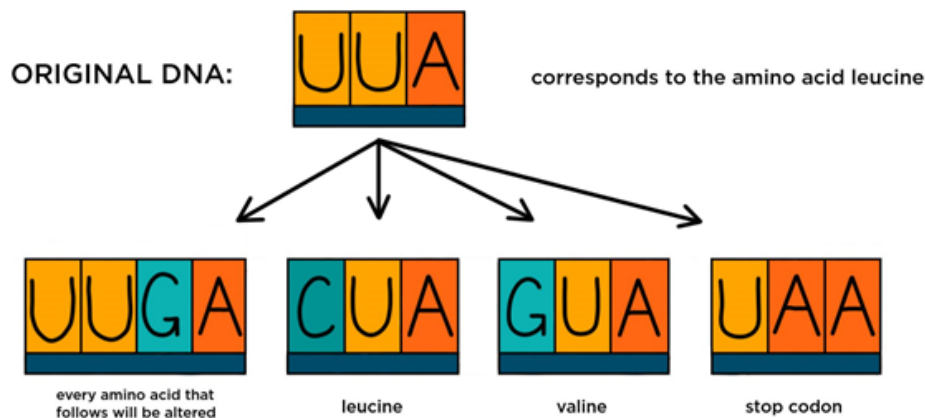

Diagram from: <https://www.expri.com/t/point-mutation-definition-types-10200>

The resultant sequence from the diagram that would be best described as a silent mutation would be

- A. UUGA
- B. CUA
- C. GUA
- D. UAA

**Question 23**

A block mutation that leads to the movement of a group of genes between different chromosomes could be referred to as

- A. An inversion
- B. A deletion
- C. A translocation
- D. A normal event

**Question 24**

Natural selection acts on

- A. Genotype
- B. Alleles
- C. Phenotype
- D. Whole populations

**Question 25**

The evolution of the horse has been well documented. From the dog sized *Eohippus* genus from 50 million years ago through to the present day *Equus* genus, which emerged about 3 million years ago. When humans and horses crossed paths in northern Eurasia about 5000 years ago, there was a rapid change in horse form. The horses in the diagram vary dramatically in size, color and temperament and are all related to the original horse called Przewalski's horse (which still exists).



Diagram from: <https://www.pinterest.com.au/pin/361273201340626338/>

The appearance of all these types of horses is due to

- A. The founder effect
- B. A genetic bottleneck
- C. Different selection pressures
- D. Artificial selection

**Question 26**

According to the current evidence, the organism that appear most recently in the fossil record are

- A. Flowering plants
- B. Mammals
- C. Animals on land
- D. Multicellular organisms

**Question 27**

The following family tree was constructed by the children of Alfred (Joe, Heather and Barbara) who had only recently located their long-lost grandparents (Jim and Jane)

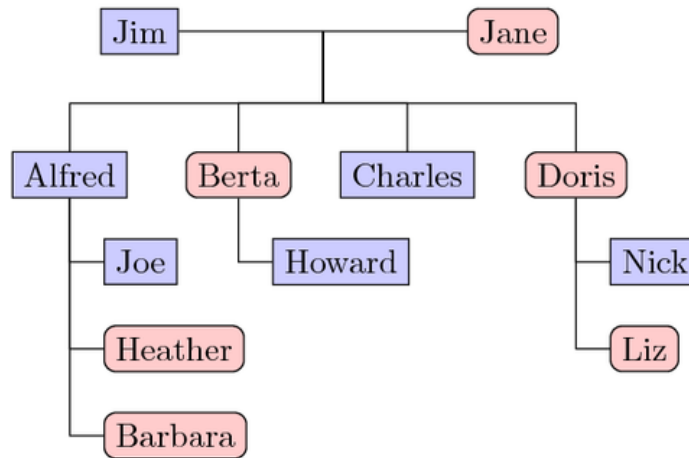

Barbara was completing Unit 3&4 Biology and was asked how many individuals in the family tree shown, would have the same mtDNA as Jane. She contemplated the family tree for a few minutes and decided that including Jane, there were

- A. 5
- B. 6
- C. 7
- D. 8

**Question 28**

With reference to the strata layers below from 3 different locations an order of age can be determined. The layers from youngest to oldest would be

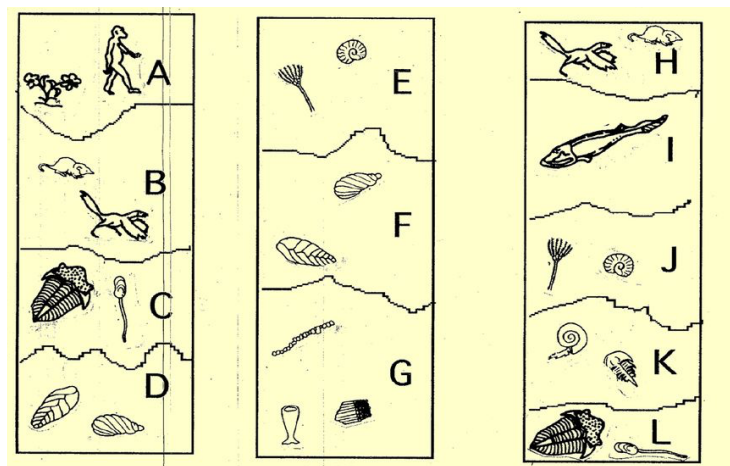

Modified from: <https://slideplayer.com/slide/16495457/>

- A. GDFLCKEJIHBA
- B. ABHIJEKCLFDG
- C. GCLJEBHKIAFD
- D. ABIJKCFGHELD



**Question 29**

Four different locations (outcrops 1 to 4) provided an excellent cross-sectional example of strata and fossils. This enabled each outcrop to be compared quite easily by using the index fossil within the strata

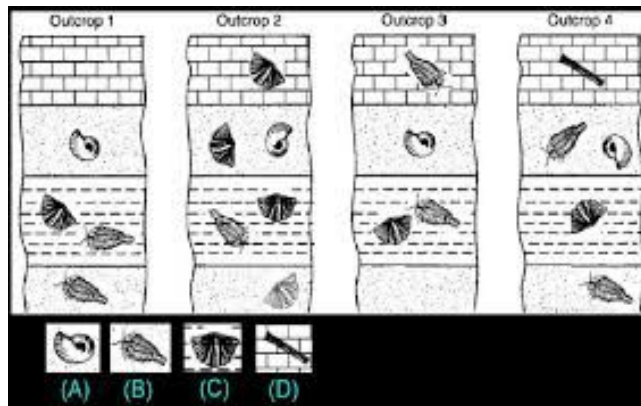

Diagram from: [https://dinopedia.fandom.com/wiki/Index\\_Fossil?file=Index\\_fossil.jpg](https://dinopedia.fandom.com/wiki/Index_Fossil?file=Index_fossil.jpg)

The index fossil is

- A. A
- B. B
- C. C
- D. D

**Question 30**

The diagrams below show four different primate craniums as seen from underneath.

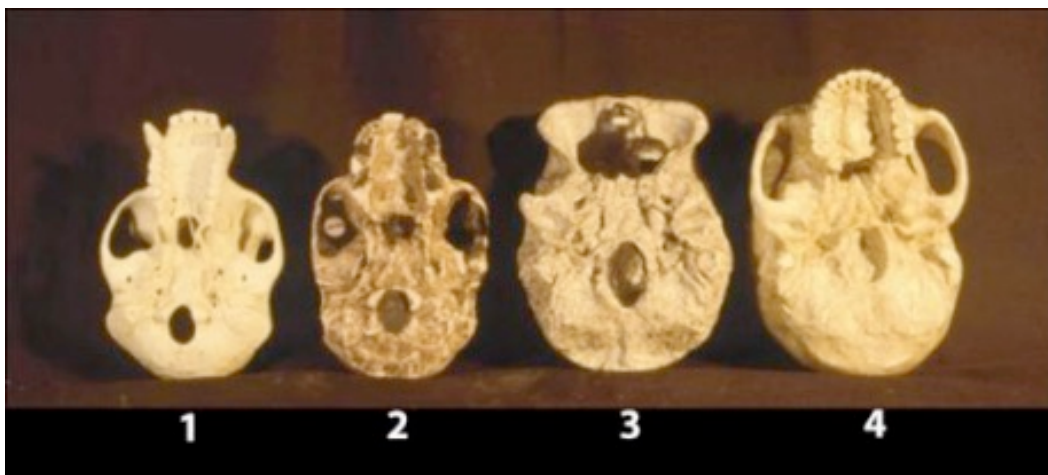

Diagram from:

<https://pdp.sjsu.edu/people/tracey.orourke/courses/anth12/s1/April1111COLOR.pdf>

The primates that are most likely to have longer arms than legs would be

- A. 1 and 2
- B. 3 and 4
- C. 2 and 3
- D. 1 and 4



**Question 31**

The most significant structural difference in the fossils of genus *Australopithecus* compared to the fossils of genus *Homo*, that gives clear supporting evidence of cognitive changes leading to more refined culture would be

- A. The big toe in line with the other toes
- B. An elongated pelvis
- C. A larger cranial capacity
- D. Large canine teeth

**Question 32**

The plasmid below shows a variety of binding sites for restriction enzymes (EcoRI, PstI and HindIII). The distance between each binding site is also shown

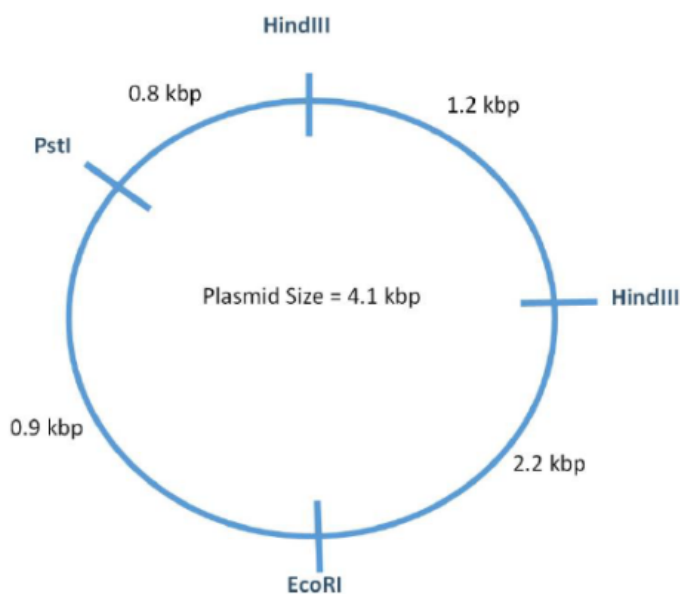
**Diagram:**

<https://di.uq.edu.au/files/7200/Booklet%203%20-%20Restriction%20Enzyme%20AnalysisV2.pdf>

If the plasmid was mixed with HindIII then

- A. One fragment of 4.1 kbp would be produced
- B. Two fragments both 4.1 kbp would be produced
- C. Two fragments would be produced, 1.2 kbp and 3.9 kbp
- D. Four fragments would be produced, 1.2 kbp, 2.2 kbp, 0.8 kbp and 0.9 kbp

**Question 33**

For the successful completion of a genetic screen as a result of gel electrophoresis, it would be advisable to

- A. Make sure the samples of DNA are the same length before being added to the wells of the gel
- B. Make sure the power switch is turned on
- C. Add the gel to the tank prior to the addition of water
- D. Attach the negative electrode to the end of the gel furthest from the wells where the DNA was added

**Question 34**

The Flavr savr tomato brand has used antisense technology to enable the tomatoes to stay ripe on the vine for longer. A sequence of mRNA was artificially manufactured that was complementary to the mRNA of the enzyme Beta polygalacturonase, which prevented the translation of the enzyme, thus hindering ripening. It did not prove to be as useful as it sounds but did provide a segue into other more successful technologies. The introduction of Flavr savr technology is an example of

- A. A complete failure of biotechnology
- B. A transgenic organism
- C. A genetically modified as well as transgenic organism
- D. A genetically modified organism

**Question 35**

Huntingtons disease is a rare autosomal dominant inherited disease that causes the progressive breakdown of nerve cells in the brain, leading to a significant change in functional abilities and usually results in movement, thinking (cognitive) and psychiatric disorders. It usually develops between the ages of 30 to 50, has no cure and is prematurely fatal. A genetic screen is available for family members of individuals who have been diagnosed with this condition. A social reason for the family members not be tested would be

- A. That it is unfair for the tested individual to know their fate
- B. That it is unfair for the tested individual to not know their fate
- C. The impact on the family by knowing the fate of a child can be alleviated
- D. The cost of the test is too much to warrant an answer

**Question 36**

Relenza targets

- A. Neuraminidase
- B. Haemagglutinin
- C. Bacteria
- D. Viral nucleic acid

**Question 37**

A disease such as Ebola (a viral disease) occasionally appears in some communities. It has a mortality rate of up to 90% of those infected. Luckily, it does not spread very easily from person to person and as a result, outbreaks are usually restricted to small geographical areas and so the disease would be classified as

- A. A pandemic
- B. Endemic
- C. An epidemic
- D. Sporadic

*The next 2 questions refer to the following information.*

Protease is an enzyme that breaks down protein in the human stomach. An experiment investigating the effect of pH on the activity of protease was conducted. 50ml of liquid gelatin (protein) was poured into petri dishes and allowed to solidify. A small central hole was created in the middle of the gelatin that allowed 2ml of 4% protease in a variety of pH buffers to be added. If the protease is functional it will digest the solid gelatin into a liquid in a pattern radiating away from the original central hole and the area of liquification ( $\text{mm}^2$ ) was calculated after 6 hours of incubation at  $30^\circ\text{C}$ . The experimenter repeated the same task 3 times for each pH. Results of the experiment are shown below

pH	Area of liquification ( $\text{mm}^2$ )		
3	1500	1450	1760
5	980	1050	1000
7	420	450	320
9	100	90	110

**Question 38**

The results of this experiment could be regarded as

- A. Accurate
- B. Precise
- C. Valid
- D. Reproduced

**Question 39**

In terms of the methodology it could be stated that

- A. The data was gained subjectively
- B. The controlled variables changed during each trial
- C. Both the independent and dependent variables were quantitative
- D. A greater variety of pH buffer solutions needed to be tested because a clear conclusion cannot be made

**Question 40**

With a hypothesis such as

“ If the concentration of protease increases, the rate of amino acid production will increase”

would be best represented with the following graph

**A.**

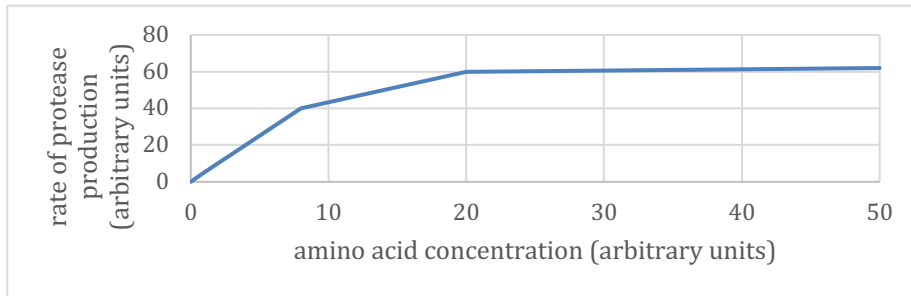

**B.**

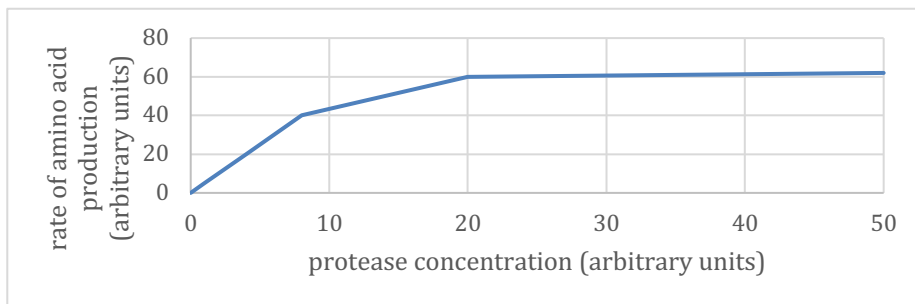

**C.**

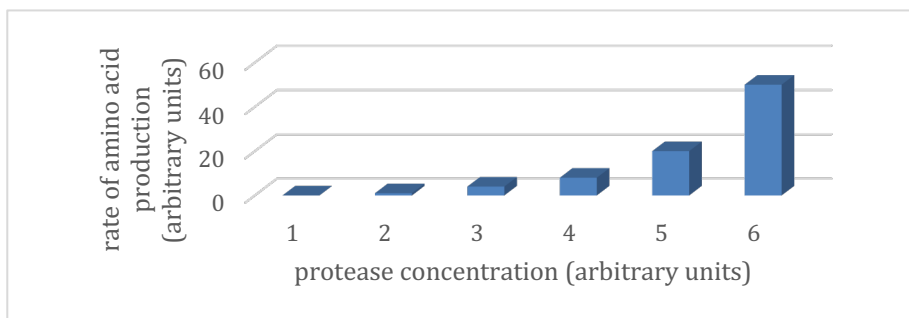

**D.**

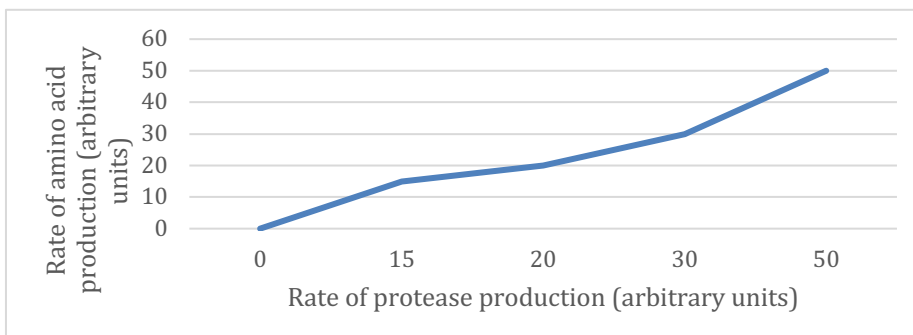

**Short Answer**

**Question 1 (Total 9 marks)**

Two biomolecules (polypeptide and nucleic acid) are shown diagrammatically below

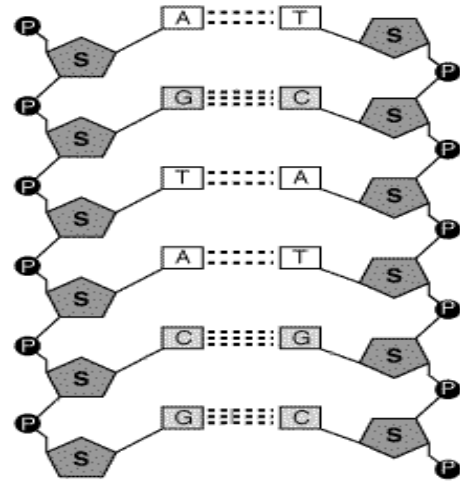
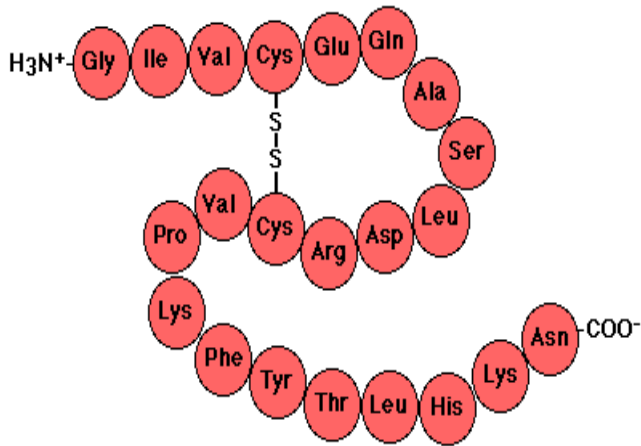

Diagrams from:

<https://www.biology-pages.info/P/Polypeptides.html>

[http://www.contexto.info/dna\\_basics/dna\\_structure/](http://www.contexto.info/dna_basics/dna_structure/)

a) On the diagrams clearly show the location of a hydrogen bond as well as a peptide bond (2 marks)

b) Write down a sequence of 3 amino acids from the diagram in the space below

(1 mark)

c) When the nucleic acid is being transcribed, why does the RNA polymerase bind to the template strand rather than the complementary strand.

---



---



---



---

(2 marks)

**Question 1 (continued)**

Consider the template sequence of TCATGC from the diagram on the previous page.

- d) Explain how the template sequence illustrated above could be transcribed and then translated into the dipeptide below

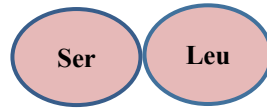

---

---

---

---

---

---

---

---

---

---

(3 marks)

**Question 2 (Total 6 marks)**

The Lac operon is a system of gene control located in *E.coli* bacteria.

- a) State the main reason for gene regulation in organisms such as *E.coli*

---

---

(1 mark)

Lactose seems to be the main factor that enables the lac operon to function

- b) Describe how the lac operon functions when lactose levels are high

---

---

---

---

---

---

---

---

(3 marks)

An experiment was conducted that investigated the effect of lactose and glucose levels on the function of the lac operon. The results of the experiment are summarized below

Carbon source	Expression of operon genes
Lactose	High
Glucose	Low
Lactose and Glucose	Low

- c) Why would there be a low expression of operon genes when both carbon sources are available?

---

---

---

---

(2 marks)

**Question 3 (10 marks)**

The mitochondria and chloroplast are very different organelles; however, they do have several similarities

- a) State and explain 3 similarities between mitochondria and chloroplasts

---

---

---

---

---

---

---

---

(3 marks)

Glucose, oxygen, carbon dioxide and water are critical for photosynthesis and respiration within plant cells.

- b) In terms of the chemicals listed above, explain how a plant can survive indefinitely when exposed to a low light intensity

---

---

---

---

---

---

---

---

(3 marks)



**Question 3 (continued)**

Cyanide is a toxic chemical that can affect both respiration and photosynthesis. This is because cytochrome oxidase has an active role in the electron transport chains of both processes and cyanide is a non-competitive inhibitor of the enzyme. The graph below shows the effect of changing substrate concentration while cyanide is present on these metabolic pathways

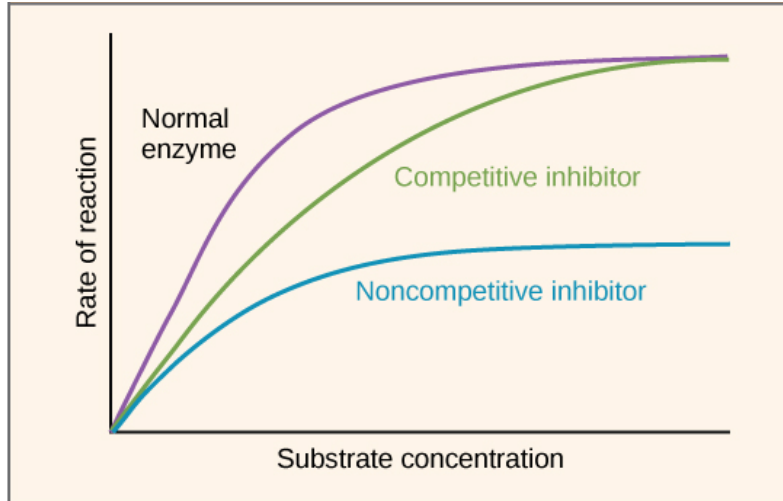

Diagram from: <https://teachmephysiology.com/biochemistry/molecules-and-signalling/enzyme-inhibition/>

- c) Why do competitive and non-competitive inhibitors effect the rate of reaction differently when substrate concentration increases?

---



---



---



---



---

(2 marks)

- d) How would the addition of cyanide specifically effect the reaction of photosynthesis?

---



---



---



---

(2 marks)

**Question 4 (9 marks)**

Signaling molecules (or ligands) vary in their mode of action as illustrated with the two diagrams shown below

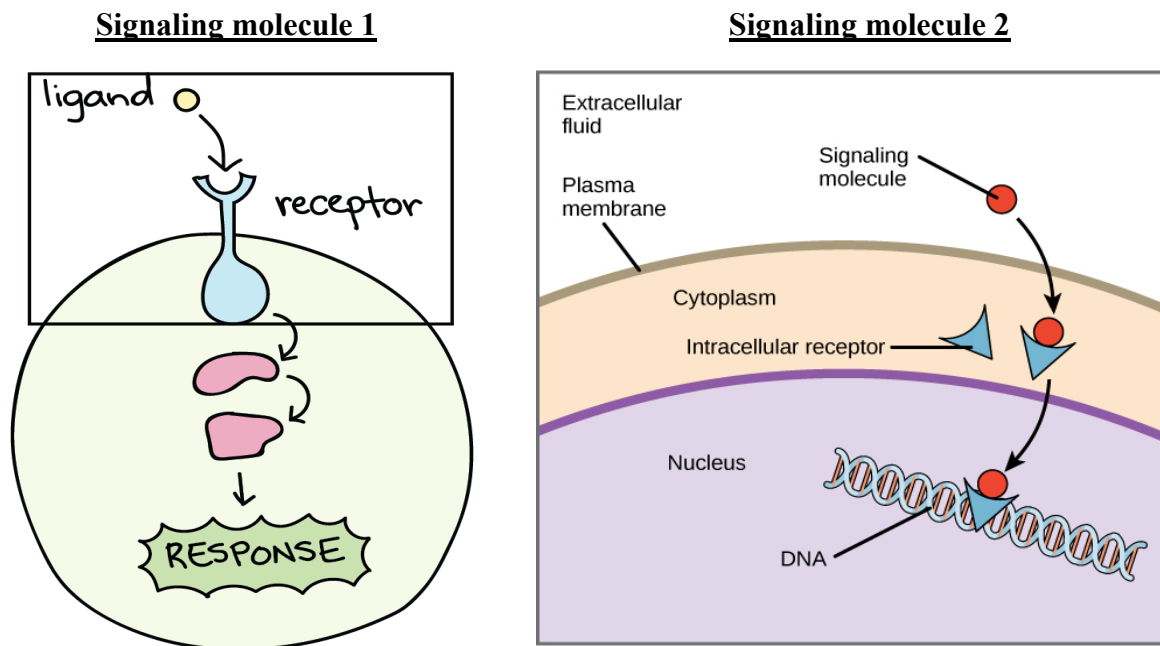

**Diagram:** <https://www.khanacademy.org/science/ap-biology/cell-communication-and-cell-cycle/signal-transduction/a/signal-perception>

a) (i) Describe a difference in the properties of each signalling molecule.

\_\_\_\_\_ (1 mark)

(ii) Describe a difference in the mode of action of each signaling molecule.

\_\_\_\_\_ (1 mark)

(iii) Explain which signaling molecule is likely to produce a longer lasting response.

\_\_\_\_\_  
 \_\_\_\_\_  
 \_\_\_\_\_ (2 marks)

**Question 4 (continued)**

- b) Pheromones and neurotransmitters are examples of signaling molecules; however, their mode of transmission is quite different. Discuss one difference in the mode of transmission between these signalling molecules.

---

---

---

(1 mark)

- c) Cytokines are regularly released from cells such as natural killer cells, that stimulate some cells to undergo apoptosis. Discuss the process of apoptosis including a type of target cell, as well as the fate of this cell.

---

---

---

---

---

---

---

---

---

---

(4 marks)

**Question 5 (7 marks)**

Some of the following cells are involved in the innate immune response, some are involved in the adaptive immune response and some form a link between the 2 types of immune response

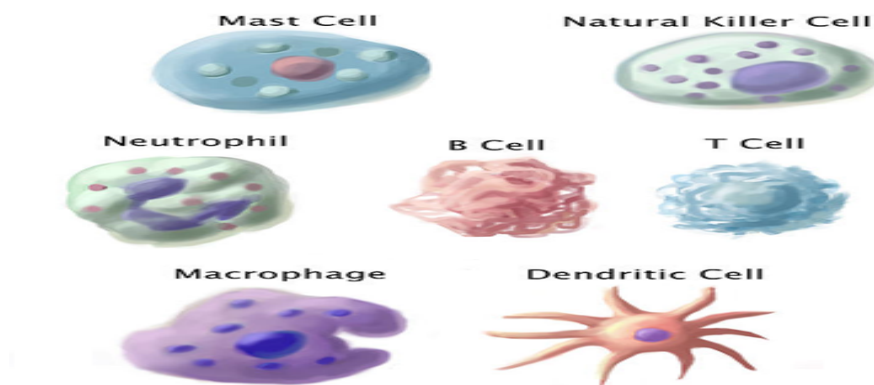

**Diagram:** <https://pixels.com/featured/immune-cells-illustration-spencer-sutton.html>

a) (i) Of the cells above, which are classified as lymphocytes?

\_\_\_\_\_ (1 mark)

(ii) In a healthy individual, which is the most prolific white blood cell in the body?

\_\_\_\_\_ (1 mark)

(iii) How is the structure of the antigen presenting cell (APC) structured to suit its function?

\_\_\_\_\_  
 \_\_\_\_\_  
 \_\_\_\_\_ (2 marks)

b) In the space below draw a labelled diagram showing the action of a mast cell when a hypersensitive person is exposed to an allergen



**(3 marks)**





**Question 7 (7 marks)**

Elephants are part of the mammal order Proboscidea and the family Elephantidae. The Elephantidae family contains two living species, *Loxodonta africana* (the African elephant) and *Elephas maximus* (the Asian elephant). The phylogenetic tree below is a summary of the evolution of the Indian and Asian elephant from a common ancestor

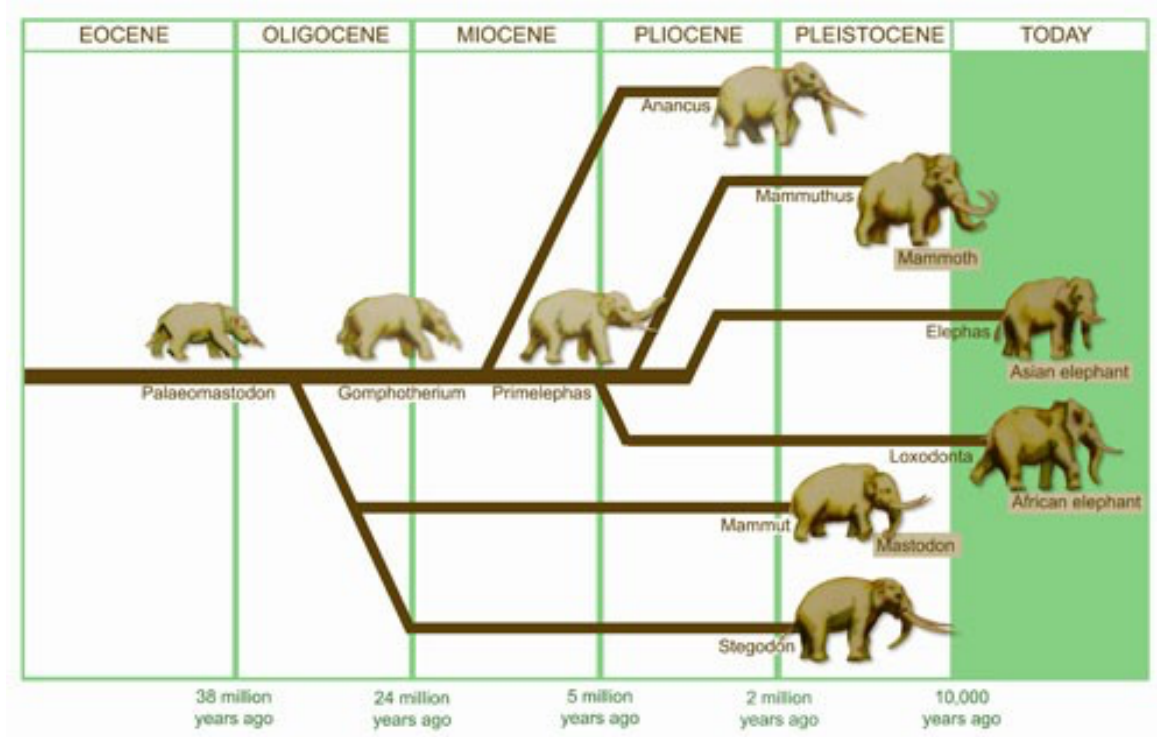

**Diagram:** <https://www.sanparks.org/parks/kruger/elephants/about/evolution.php>

a) (i) How long ago did the Indian and Asian elephants have a common ancestor?

(1 mark)

---

(ii) What evidence would be required for the evolutionary story depicted by the Mammoth?

---



---



---



---

(2 marks)

---

**Question 7 (continued)**

There is much debate over whether all African elephants are from one species. Strong genetic evidence suggests that there may be two, or even three, different species within Africa. The current scientific classification breaks the African elephant down into two sub species, *Loxodonta africana cyclotis* (the forest elephant) and *Loxodonta africana africana* (the savanna elephant).

- b) What evidence would exist that places the African elephants into sub species rather than separate species?

---

---

---

---

---

(2 marks)

- c) A *Palaeomastodon* fossil was discovered in northern Africa in a layer of volcanic rock and after analysis of the fossil it was placed as the common ancestor to all the elephants shown. How could absolute dating determine that the *Palaeomastodon* fossil was 38 million years old by using a common isotope from the volcanic layer (isotope X) that has a half-life of 8 million years.

---

---

---

---

---

(2 marks)



**Question 8 (Total 6 marks)**

DNA hybridization is used as a quantitative measure to determine the level of relatedness between organisms

- a) How would a quantitative measure compare to a qualitative measure in determining relatedness between organisms?

---



---



---

(1 mark)

- b) Describe how the technique of DNA hybridisation would show a difference in relatedness between 2 closely related species

---



---



---



---



---



---

(3 marks)

4 species were investigated to determine their relatedness. The results of such an investigation are listed below. The data is presented as the average % differences between the nucleotides in the same gene locus for all the organisms tested

Species	Human	Chimpanzee	Gorilla	Human
Human	0	NA	NA	NA
Chimpanzee	1	0	NA	NA
Gorilla	4	3	0	NA
Gibbon	6	5	5	0

- c) Construct an evolutionary tree in the space below using the data provided that shows the likely evolutionary relationship between these 4 primates. Include a common ancestor in your response.

(2 marks)

**Question 9 (Total 4 marks)**

The diagram below represents a branch of biotechnology using gel electrophoresis. In this circumstance the wells and DNA have not been added.

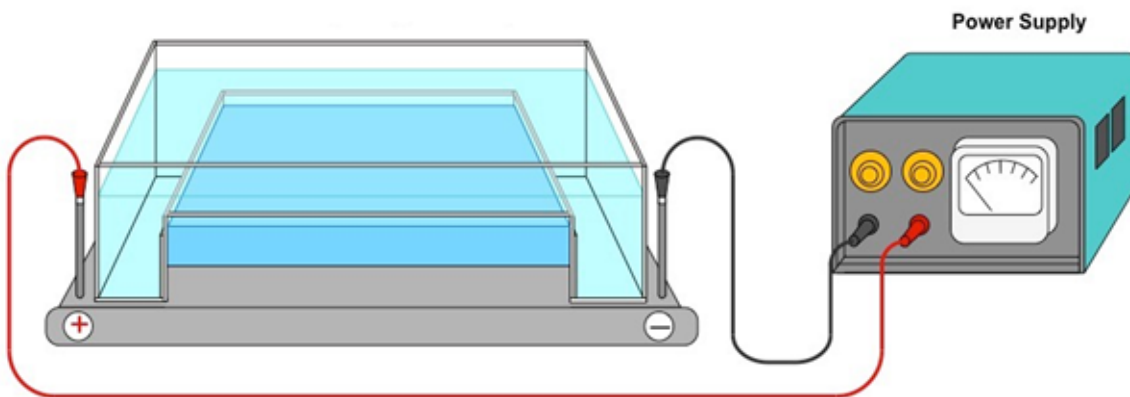

**Diagram:** <https://ib.bioninja.com.au/standard-level/topic-3-genetics/35-genetic-modification-and/gel-electrophoresis.html>

- a) Draw on the diagram where the wells should be located so that when the DNA is added a genetic profile can be constructed. (1 mark)

3 wells were made, and samples of DNA were added to each well. The samples contained DNA fragments of differing size as shown in the table below

Sample	Fragment sizes (Kb)
1	50
2	20, 30
3	5, 10, 15, 20

- b) Draw the genetic profile (including the position of the wells) that would appear after the process of gel electrophoresis was completed and the gel was stained.

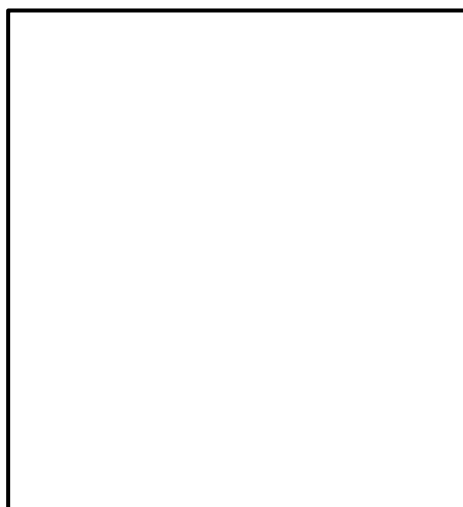

(3 marks)

**Question 10 (Total 14 marks)**

Rice plants provide a staple food for a large proportion of the world's population.

The rice plants grow in wet oxygen depleted environments, which is not ideal for cell respiration efficiency; however, it does provide an environment for the rice plants to grow roots into.

A scientist was interested in increasing the oxygen levels of the soil that rice plants were growing in because he thought the biomass of rice per plant would increase. He followed the following method

- 10 saturated soil samples in growth pots were obtained
- Each pot was connected to an aerator that could provide variable amounts of oxygen at a constant rate
- 5 different levels of oxygen were set from 0% to 20% in equal increments
- Equally sized rice plants were placed into each pot and left for 30 days
- The mass of the pots was measured at the beginning and at the end of the allocated time
- A rate of mass increase was calculated using the averages from each level of oxygen provided

a) What is the hypothesis for this experiment?

---

---

---

---

(1 mark)

b) What is the purpose of the pot provided with no oxygen?

---

---

---

---

(2 marks)

c) State 2 variables from the method given that were kept constant throughout all the experimental trials

---

---

---

(2 marks)

**Question 10 (continued)**

The results obtained are illustrated below as a line graph

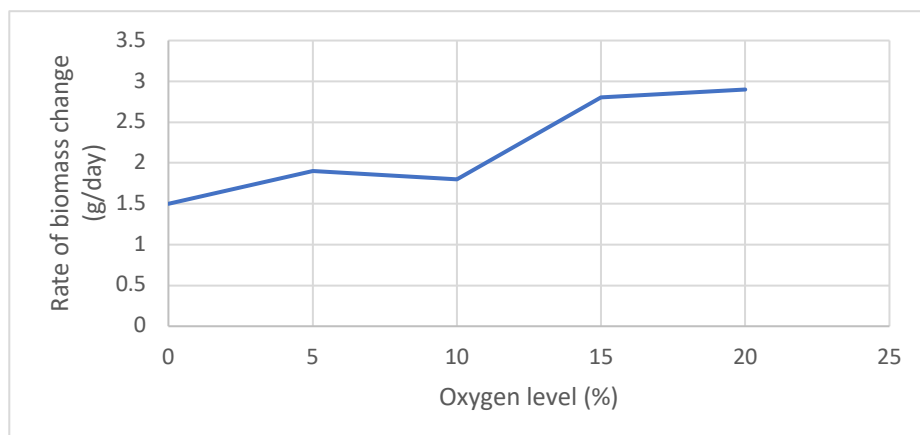

d) Explain the results at 0% oxygen

---



---



---



---



---

(3 marks)

The result gained at 10% oxygen was confusing because the experimenter gained the results below for the 2 pots

Pot number	Average change in biomass (g/day)
1	1.5
2	2.1

He discovered a random error occurred for pot 1, which was not evident for any of the other trials conducted

e) (i) What was the most likely cause of the random error?

---



---

(1 marks)

(ii) Would the result for pot number 2 be a more likely result to accept on its own rather than do another trial?

---



---

(1 mark)

**Question 10 (continued)**

- f) For commercial purposes, aerated soil is expensive to maintain; however, the productivity gained through aerating is evident in the data gained. Based on the data provided, state and explain the minimum amount of aeration recommended for the best productivity.

---

---

---

---

(2 marks)

- g) State a limitation evident in this experiment and explain how this limitation could be reduced to generate a more reliable outcome.

---

---

---

---

(2 marks)

**End of questions for the 2021 Kilbaha VCE Biology Trial Examination Units 3 and 4**

**Kilbaha Education**  
**PO Box 2227**  
**Kew Vic 3101**  
**Australia**

**Tel: (03) 9018 5376**

[kilbaha@gmail.com](mailto:kilbaha@gmail.com)  
<https://kilbaha.com.au>