



Trial Examination 2011

# VCE Biology Unit 3

Written Examination

## Question and Answer Booklet

Reading time: 15 minutes  
Writing time: 1 hour 30 minutes

Student's Name: \_\_\_\_\_

Teacher's Name: \_\_\_\_\_

### Structure of Booklet

Section	Number of questions	Number of questions to be answered	Number of marks
A	25	25	25
B	8	8	50
			Total 75

Students are permitted to bring into the examination room: pens, pencils, highlighters, erasers, sharpeners and rulers. Students are NOT permitted to bring into the examination room: blank sheets of paper and/or white out liquid/tape. No calculator is allowed in this examination.

#### Materials supplied

Question and answer booklet of 21 pages.  
Answer sheet for multiple-choice questions.

#### Instructions

Write your **name** and **teacher's name** on this booklet and in the space provided on the answer sheet for multiple-choice questions. All written responses should be in English.

#### At the end of the examination

Place the answer sheet for multiple-choice questions inside the front cover of this booklet.

**Students are NOT permitted to bring mobile phones and/or any other unauthorised electronic devices into the examination room.**

Students are advised that this is a trial examination only and cannot in any way guarantee the content or the format of the 2011 VCE Biology Unit 3 Written Examination.

Neap Trial Exams are licensed to be photocopied or placed on the school intranet and used only within the confines of the school purchasing them, for the purpose of examining that school's students only. They may not be otherwise reproduced or distributed. The copyright of Neap Trial Exams remains with Neap. No Neap Trial Exam or any part thereof is to be issued or passed on by any person to any party inclusive of other schools, non-practising teachers, coaching colleges, tutors, parents, students, publishing agencies or websites without the express written consent of Neap.

**SECTION A: MULTIPLE-CHOICE QUESTIONS****Instructions for Section A**

Answer **all** questions in pencil on the answer sheet provided for multiple-choice questions.

Choose the response that is **correct** for the question.

A correct answer scores 1, an incorrect answer scores 0.

Marks will **not** be deducted for incorrect answers.

No marks will be given if more than one answer is completed for any question.

**Question 1**

A combination of carbohydrates that only contains polysaccharides is

- A. starch and sucrose.
- B. glucose and glycogen.
- C. ribose and fructose.
- D. cellulose, glycogen and starch.

**Question 2**

The following diagram illustrates a series of biochemical reactions occurring within a typical cell. Letters *M*, *N*, *O* and *P* represent different stages of the biochemical reactions.

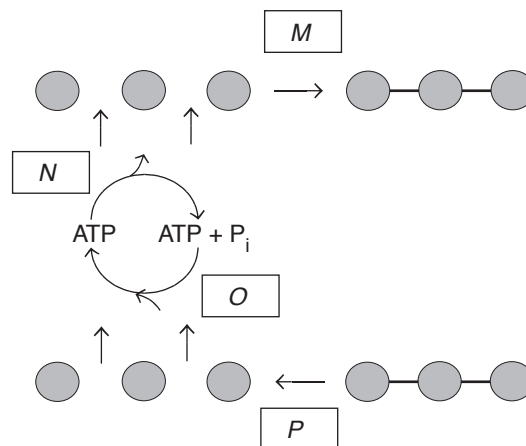

Exergonic reactions are best represented by

- A. *P* and *N*.
- B. *N* and *O*.
- C. *O* and *P*.
- D. *M* and *N*.

Questions 3 and 4 refer to the following information.

The following diagram represents an antibody.

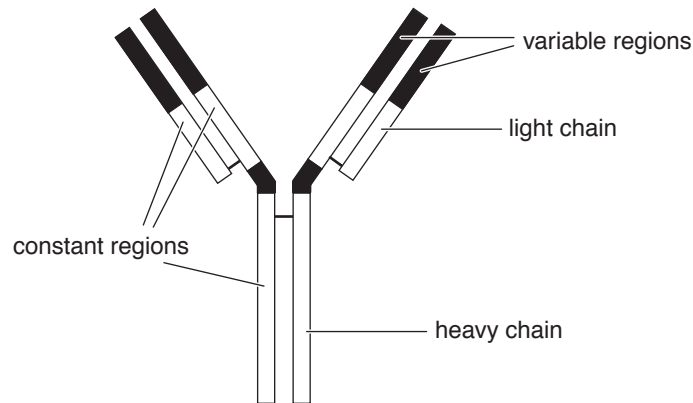

### Question 3

The monomers making up the heavy and light chains are

- A. nucleotides.
- B. fatty acids.
- C. amino acids.
- D. glucose.

### Question 4

The correct functions of the parts of this antibody would be for

- A. the two variable regions to bind to two structurally different antigens.
- B. the constant regions to bind to the antigen in the surface of a pathogen.
- C. the variable regions to have a shape that is complementary to the antigen.
- D. the variable regions to have a shape that is identical to the antigen.

### Question 5

Bonding between amino acids can cause a polypeptide to form an  $\alpha$  helix or a  $\beta$  sheet.

This configuration is called

- A. a secondary structure.
- B. an active site.
- C. a tertiary structure.
- D. a primary structure.

Questions 6 and 7 refer to the following information.

The following diagrams illustrate the action of an enzyme.

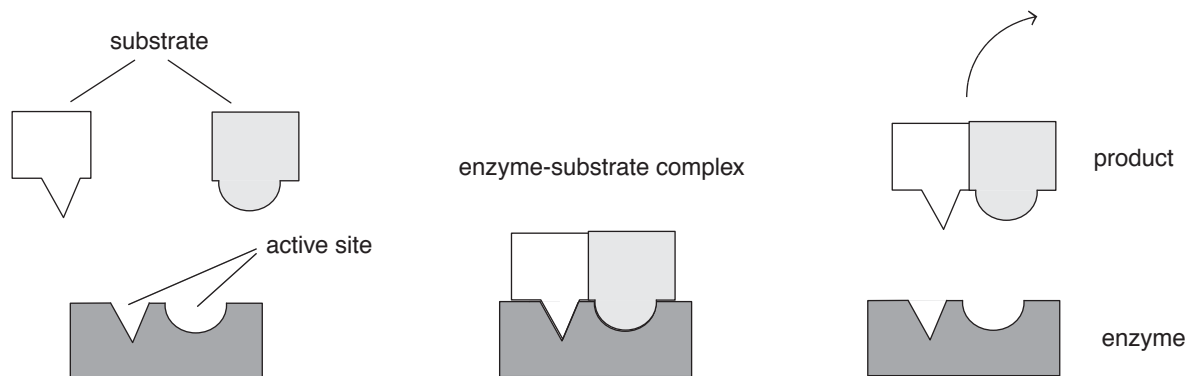

### Question 6

This enzyme is catalysing

- A. a catabolic reaction.
- B. an anabolic reaction.
- C. a hydrolysis reaction.
- D. a reversible reaction.

### Question 7

The enzyme-substrate complex forms because

- A. the substrates find the active sites.
- B. the substrates collide with the enzyme.
- C. the enzyme looks for the substrates.
- D. our body needs the product.

### Question 8

A feature of the phospholipid bilayer of a cell membrane is

- A. hydrophobic phosphate groups found on the exterior of the bilayer.
- B. hydrophilic fatty acids found in the interior of the bilayer.
- C. phospholipids in the bilayer often having non-polar molecules attached to the phosphate group.
- D. the fatty acid component of the phospholipids in the bilayer being insoluble in water because of the large number of non-polar C-H bonds in them.

### Question 9

The chemical bonds that are directly involved in base pairing in DNA are

- A. covalent bonds.
- B. phosphodiester bonds.
- C. hydrogen bonds.
- D. disulfide bonds.

**Question 10**

- I. concentration of  $\text{CO}_2$  in the leaf
- II. concentration of  $\text{O}_2$  in the leaf
- III. temperature

Of the above, factors affecting the output of the light-independent reactions of photosynthesis in plants are

- A. I and II only.
- B. I and III only.
- C. I only.
- D. I, II and III.

**Question 11**

An electron transport chain is an essential part of the following cellular processes of

- A. aerobic respiration and photosynthesis.
- B. protein synthesis and photosynthesis.
- C. glycolysis and anaerobic respiration.
- D. aerobic respiration and phototropism.

**Question 12**

Of the following, the most accurate statement is that

- A. the Krebs's cycle occurs in the mitochondrial matrix.
- B. polypeptide synthesis is transcription.
- C. the light-independent reaction occurs on the thylakoid membranes.
- D. DNA replication occurs in the cytosol of eukaryotes.

**Question 13**

The following diagram shows the complex interconnection between many neurons in the central nervous system.

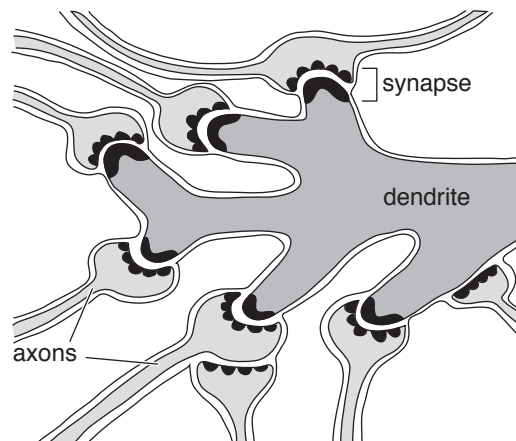

It would be true to say that

- A. neurotransmitters would be released from the post-synaptic side of the synapse.
- B. the action potential along the axons involves movement of sodium and chloride ions across the membrane.
- C. an influx of calcium ions leads to exocytosis of neurotransmitters into the synapse.
- D. a drug with a similar shape to the neurotransmitter would always lead to a reduced nerve transmission in the dendrite.

**Question 14**

A botanist is having difficulty getting seeds to germinate.

The hormone she could apply to the seeds to help induce germination would be

- A. auxin.
- B. gibberellin.
- C. abscisic acid.
- D. ethylene.

**Question 15**

IAA (indole acetic acid) is an auxin that affects the phototropic growth responses of plants.

The diagrams below show the results of some experiments investigating the effect of unidirectional light on IAA in the stems of cucumber plants. In each experiment, auxin is produced in the tips of shoots and diffuses downwards to enter a block of agar jelly. IAA can diffuse freely through the agar.

The numbers in the diagram indicate the concentrations of IAA in the agar in  $\mu\text{g/L}$  at the end of each experiment. Shoot tips P and Q were kept in total darkness.

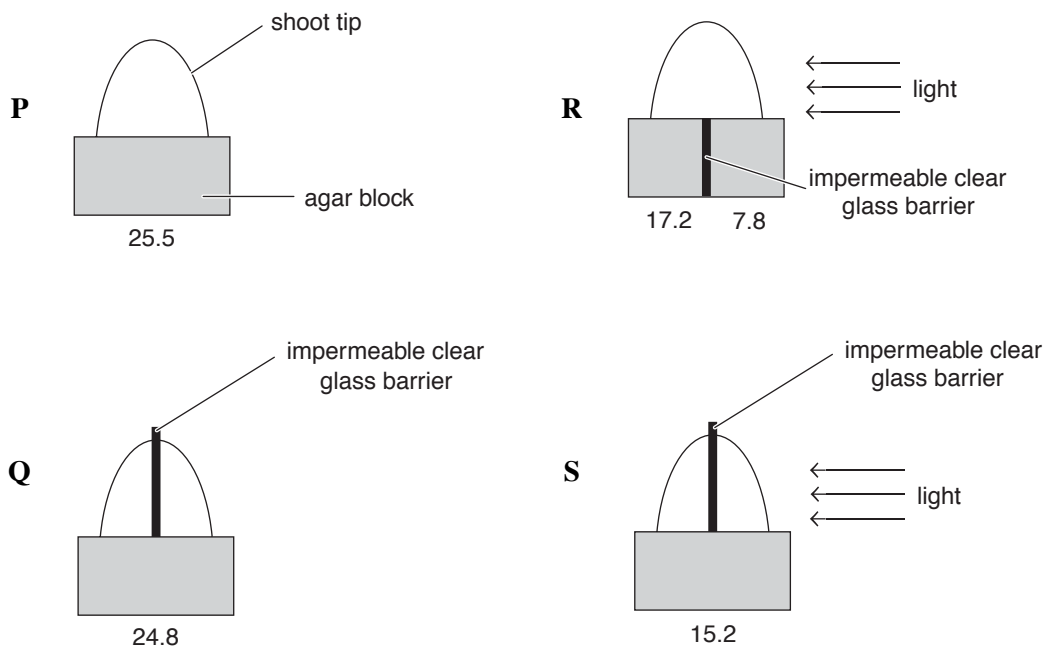

From these experimental results, the most reasonable conclusion would be that

- A. experiments P, Q, R and S indicate that the production of IAA by the shoot tip is unaffected by light.
- B. experiments R and S show that illumination of cells in the shoot tip reduces their ability to produce IAA.
- C. experiment Q serves as a control for experiment R.
- D. experiments Q and S show that the impermeable glass barrier affects the production and distribution of IAA in the shoot tip.

**Question 16**

The human thyroid gland is controlled by a negative feedback mechanism. The hypothalamus secretes thyrotropin-releasing hormone (TRH). TRH stimulates the anterior pituitary to secrete thyroid stimulating hormone (TSH). TSH induces the thyroid gland to secrete thyroxine.

The next step in the control system is

- A. thyroxine will inhibit the secretion of TRH by the hypothalamus.
- B. the hypothalamus will secrete a thyroid-inhibiting hormone that slows down production of thyroxine.
- C. thyroxine will stimulate the increased production of TSH.
- D. the rising level of thyroxine will act on the pituitary gland to slow down the production of TSH.

**Question 17**

Many of the molecules involved in signal transduction are found attached to the inner or outer surfaces of the cell membrane. Others are found in the cytosol.

Of the following, the signal transduction molecules generally found in the cytosol are

- A. cyclic AMP (cAMP).
- B. peptide hormone receptors.
- C. G proteins.
- D. adenylate cyclase.

**Question 18**

The correct structural difference between a virus and a bacterium is

- A. a virus is prokaryotic and a bacterium is eukaryotic.
- B. a virus is much smaller than a bacterium.
- C. a virus has antigens but a bacterium does not.
- D. a virus contains only RNA while a bacterium contains only DNA.

**Question 19**

Most foods left outside the refrigerator will rapidly become spoiled with growths of bacteria and fungi. However, most microorganisms will not grow on the surface of honey which is a mixture of fructose and glucose.

The most likely reason for this is that

- A. the sugars in honey are toxic to most microorganisms.
- B. microorganisms do not use sugars as an energy source.
- C. honey is hypotonic to the cells of the microorganisms, causing them to take up water and burst.
- D. honey is hypertonic to the cells of the microorganisms, causing them to lose water and plasmolyse (shrink).

**Question 20**

*Echinococcus granulosus* is a pathogenic tapeworm that has a complicated life cycle. It is transmitted from human to human when people drink water that has been contaminated with faeces.

A physical or chemical barrier that would help prevent the tapeworm from causing disease in the human body would be

- A. the ciliated lining of the bronchioles in the lungs.
- B. the acidity of the stomach.
- C. unbroken skin.
- D. tears from the tear duct having antibacterial properties.

**Question 21**

Immediate allergic hypersensitivity usually involves

- A. mast cells.
- B. antibodies.
- C. histamines.
- D. all of the above

**Question 22**

Human blood types are classified according to the antigens found on red blood cells. People whose cells carry the Rhesus antigen are described as Rh positive. A woman who is Rh negative falls pregnant with a baby that is Rh positive. During the pregnancy, some of the baby's blood cells get into the mother's blood stream and she forms antibodies against the baby's blood.

This is likely to endanger the baby because

- A. the mother possesses Rh antigens not present on the baby's red blood cells.
- B. the baby is unable to mount an immune response against the mother's red blood cells.
- C. anti-Rh antibodies pass across the placenta from the mother to the baby, attacking and bursting the baby's red blood cells.
- D. the baby produces anti-Rh antibodies which cross the placenta and cause anaemia in the mother.

**Question 23**

The leaf below shows signs of disease. To determine the type of pathogen causing the disease, a sample of the diseased portion of the leaf was placed on a sterile agar plate. The end result was an agar plate completely covered with thread-like filaments.

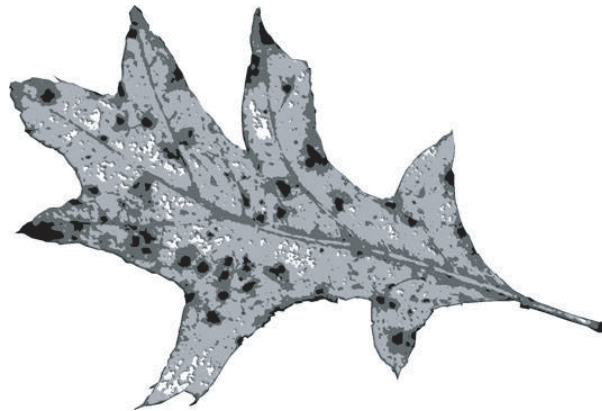

The pathogen causing this disease is most likely to be

- A. a fungus.
- B. a prion.
- C. an endoparasite.
- D. a virus.



**Question 24**

Cytotoxic T cells induce cell death. They contain lysosomes full of perforin. Upon binding to a target cell, the T cell releases perforin that leads to the death of the target cell by rupturing the target cell membrane.

In relation to this process, it is most accurate to state that

- A. cytotoxic T cells could bind to a variety of target cells.
- B. cytotoxic T cells would be formed via clonal expansion.
- C. perforin would be released from cytotoxic T cells by endocytosis.
- D. perforin is a type of antibody.

**Question 25**

Artificial passive immunity is acquired by

- A. introducing antigens into the body.
- B. preventing the action of interferons.
- C. introducing anti-histamines into the body.
- D. introducing antibodies into the body.

**SECTION B: SHORT-ANSWER QUESTIONS**

**Instructions for Section B**

Answer this section in **pen**.

Answer all questions in the spaces provided.

**Question 1**

The series of diagrams below show the same acinar cell in a salivary gland. Salivary acinar cells synthesise salivary amylase.

The cell is shown 3, 7 and 120 minutes after radioactively-labelled amino acids were introduced into the cytosol.

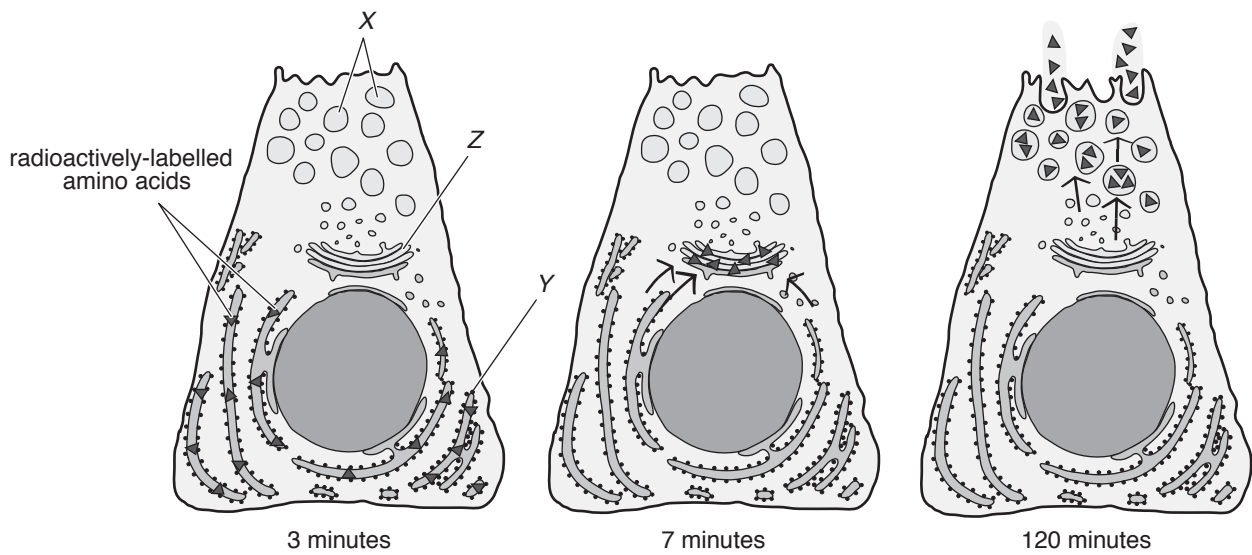

a. Name the process by which amylase is secreted from an acinar cell.

\_\_\_\_\_

1 mark

b. Identify structures X, Y and Z.

X

\_\_\_\_\_

Y

\_\_\_\_\_

Z

\_\_\_\_\_

2 marks

- c.** With reference to the functions of structures *X*, *Y* and *Z* and the role of the acinar cell, explain the fate of the radioactively-labelled amino acids after their introduction into the cytosol.

---

---

---

---

---

---

---

---

3 marks  
Total 6 marks

**Question 2**

RNA polymerase (RNAP) is an enzyme that catalyses the production of RNA from a DNA template.

- a. Name this process.

\_\_\_\_\_

1 mark

The diagram below illustrates this process.

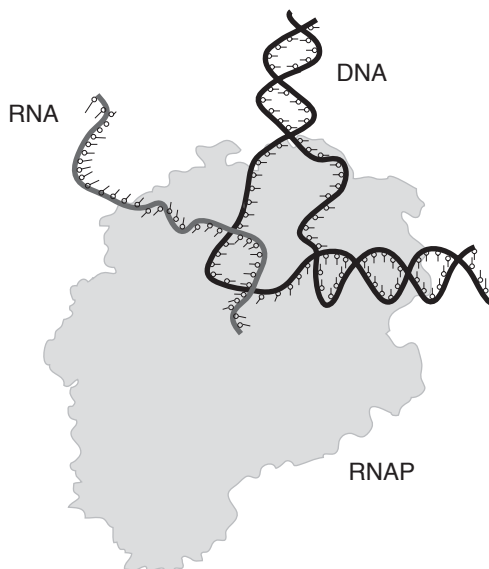

- b. Complete the table below to show the **structural differences** between the RNAP, RNA and DNA.

Biomolecule	Difference 1	Difference 2
RNAP		
RNA		
DNA		

3 marks

- c. Discuss the change in function of RNAP if it is exposed to cooler conditions than its optimum.

\_\_\_\_\_  
 \_\_\_\_\_

1 mark

RNAP catalyses many steps in the process where DNA is converted into RNA. This is quite unusual in that most enzymes catalyse one chemical reaction only.

- d. Using an understanding of enzyme structure and function, give **one** reason which would explain how RNAP can catalyse many steps.

\_\_\_\_\_  
 \_\_\_\_\_  
 \_\_\_\_\_

1 mark

Total 6 marks

**Question 3**

A student conducted two experiments into respiration in living organisms.

In Experiment A, the student put some germinating barley seeds in a conical flask at 25°C and 1 atm. With the help of a thread, she suspended a small tube containing concentrated potassium hydroxide solution (KOH) inside the flask. She then connected one end of a glass tube to the flask, placing the other end of the tube in a beaker filled with water. She then made the apparatus air tight and noted the level of water in the tube after 8, 16 and 24 hours.

In Experiment B, she repeated the experiment exactly, but replaced the KOH with pyrogallate, a chemical that absorbs oxygen from the atmosphere.

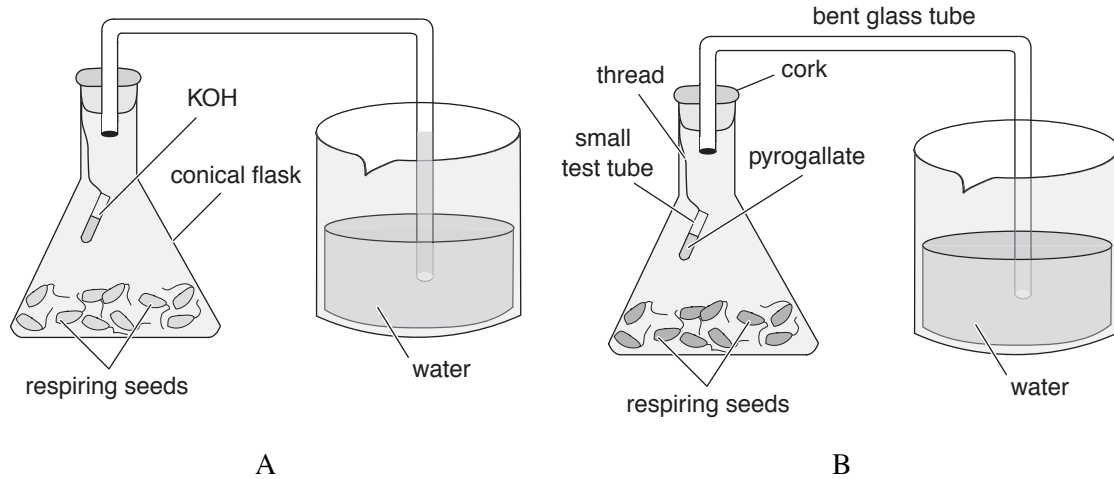

The results of the experiments are shown in the table below.

Experiment A		Experiment B	
Time (hours)	Water level in tube	Time (hours)	Water level in tube
0–8	rose 13 mm	0–8	rose 12 mm
8–16	rose 10 mm	8–16	fell 5 mm
16–24	rose 4 mm	16–24	fell 9 mm

In Experiment A, the student observed that the water level in the glass tube rose overnight. The rise in the level of water is due to a partial vacuum created in the flask because the gas produced during respiration is absorbed by KOH.

- a. Name the gas produced.

1 mark

- b. Write a balanced chemical equation for the gas-producing process occurring in the barley seeds in Experiment A.

2 marks

- c.** Explain why the water level rose less between 16–24 hours in Experiment A than during the preceding time periods.

---

---

---

---

---

2 marks

- d.** Explain the change in the water level in Experiment B after 8 hours.

---

---

---

---

---

1 mark

Total 6 marks

**Question 4**

A biologist wanted to measure the change in carbon dioxide levels over time around a tomato plant *Solanum lycopersicum*. The initial experiment was set up in an environment with a constant amount of light, heat and humidity. The changes in carbon dioxide around the plant were measured over a 10 hour period and a graph of the data obtained is illustrated below.

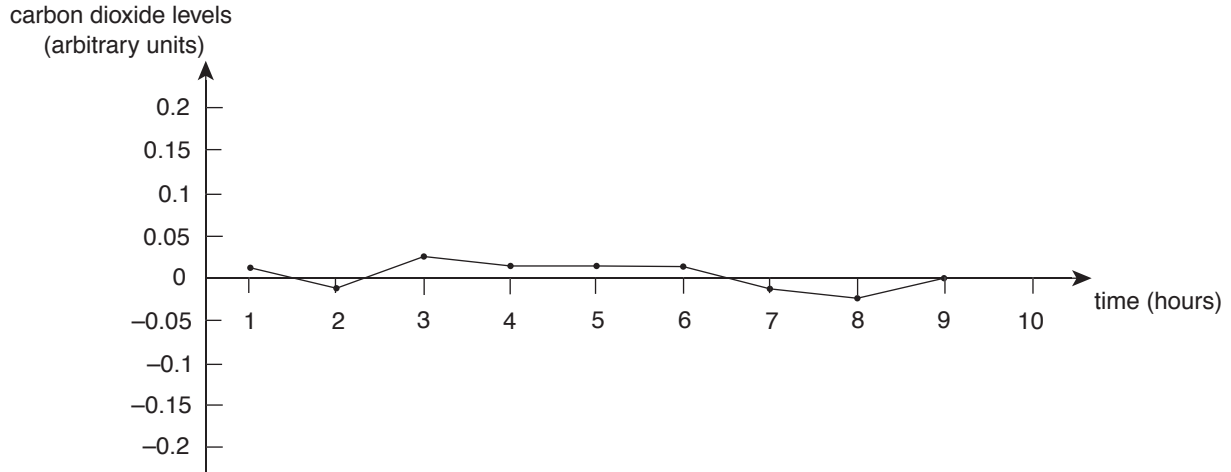

- a. State the carbon dioxide levels at 4 hours.

\_\_\_\_\_

1 mark

The biologist noticed that the carbon dioxide levels remained at 0 arbitrary units for the duration of the experiment.

- b. Explain why this was the case.

\_\_\_\_\_

\_\_\_\_\_

\_\_\_\_\_

2 marks

- c. i. Draw the results expected on the graph if the light intensity was doubled.

1 mark

- ii. Explain your answer

\_\_\_\_\_

\_\_\_\_\_

1 mark  
Total 5 marks

**Question 5**

The concentration of calcium in human blood is under homeostatic control. When the concentration of calcium in the blood begins to fall the parathyroid gland releases parathyroid hormone. This hormone stimulates bone cells called osteoclasts to break down bone and release calcium into the blood.

When the concentration of calcium rises in the blood, cells in the thyroid gland release the hormone calcitonin. Calcitonin acts on bone cells and increases the amount of calcium that is deposited into bone.

- a. In the space below, draw a diagram of the feedback mechanisms described above.  
Clearly indicate any negative feedback processes.

3 marks

- b. What is meant by negative feedback?

---

---

1 mark

Research findings have indicated that low oestrogen levels are directly linked to osteoporosis (the loss of calcium and other minerals from the bone), causing a decrease in bone mass. This makes the bones brittle and easy to fracture.

Use this information and your flow chart to answer the following questions.

- c. Explain the likely effect of oestrogen on the secretion and function of parathyroid hormone.

---

---

---

---

---

2 marks



- d.** Describe how daily calcium supplements could help older women reduce the risk of osteoporosis.

---

---

---

---

1 mark

- e.** Vitamin A is used to treat some skin conditions and many women use vitamin A preparations to promote 'younger looking skin'. One of the hazards of using vitamin A is that it stimulates the actions of osteoclasts.

Explain how this would affect the blood calcium level.

---

---

---

---

1 mark

Total 8 marks



**Question 7**

**Paroxysmal nocturnal haemoglobinuria** (PNH) is a rare, but potentially life-threatening disease of the blood characterised by complement-induced destruction of red blood cells. This leads to red urine (due to the appearance of haemoglobin in the urine) and thrombosis (blood clots).

- a. List one factor that is involved in blood clotting and describe its role in this process.

---

---

---

2 marks

The disease is caused by a defect in the cell membrane of red blood cells due to a deficiency of a glycolipid protein that normally functions as **one** of the anchors for a variety of important membrane proteins. In PNH, protectin (a complement regulatory protein) is not properly anchored to red blood cells. Without these proteins linked to the cell surface, the complement system can specifically destroy these cells, leading to PNH. Luckily not all of the body's cells have the same problem.

- b. i. What is a glycolipid protein?

---

1 mark

- ii. How does the complement system destroy red blood cells?

---

---

---

1 mark

- iii. Why would PNH be specific to red blood cells?

---

---

---

1 mark

PNH has traditionally been treated using blood transfusions and anti-clotting medications but recently a new drug called 'Solaris' is proving to be quite successful. Solaris is produced using monoclonal antibody technology. It protects blood cells by inhibiting the complement system.

- c. What is a 'monoclonal antibody'?

---

---

---

2 marks

Unfortunately the Australian Government has not approved the use of Solaris by Australian patients and this medication in June 2010 cost \$20 000 per month, making it the world's most expensive drug. Use of this drug has extended the life expectancy of PNH patients in 30 other countries where it is heavily subsidised.

- d.** Describe one scientifically testable benefit the Pharmaceutical Benefits Scheme Advisory Board would need to observe for Solaris to be subsidised by the Australian Government.

---

---

---

1 mark  
Total 8 marks

**Question 8**

Meningococcal disease – caused by the bacteria *Neisseria meningitidis* – can cause meningitis. Patients with an illness caused by the meningococcal bacteria may have a sudden onset of high fever as well as some other life-threatening symptoms.

- a. Using your understanding of the immune system, why would a sufferer experience the onset of a high fever when contracting meningococcal disease?

---

---

---

2 marks

Meningitis is spread through the exchange of respiratory and throat secretions.

- b. What is one **non medical** action that could be taken to reduce the spread of meningococcal disease?

---

---

1 mark

Antibiotics are available for sufferers of the disease but a recent vaccination program in Australia successfully reduced the chance of individuals contracting meningococcal disease.

- c. Explain how the immune system works for the vaccine to confer long-term immune memory against meningococcal disease.

---

---

---

---

---

---

---

3 marks

Total 6 marks

**END OF QUESTION AND ANSWER BOOKLET**